

Applied Finite Mathematics

Collection Editor:

Rupinder Sekhon

Applied Finite Mathematics

Collection Editor:

Rupinder Sekhon

Authors:

UniqU, LLC

Rupinder Sekhon

Online:

< <http://cnx.org/content/col10613/1.5/> >

C O N N E X I O N S

Rice University, Houston, Texas

This selection and arrangement of content as a collection is copyrighted by Rupinder Sekhon. It is licensed under the Creative Commons Attribution 3.0 license (<http://creativecommons.org/licenses/by/3.0/>).

Collection structure revised: July 16, 2011

PDF generated: October 26, 2012

For copyright and attribution information for the modules contained in this collection, see p. 337.

Table of Contents

1	Linear Equations	1
2	Linear Equations: Homework	25
3	Matrices	43
4	Matrices: Homework	77
5	Linear Programming: A Geometric Approach	97
6	Linear Programming: A Geometrical Approach: Homework	109
7	Linear Programming: The Simplex Method	115
8	Linear Programming: The Simplex Method: Homework	129
9	Mathematics of Finance	135
10	Mathematics of Finance: Homework	155
11	Sets and Counting	169
12	Sets and Counting: Homework	193
13	Probability	209
14	Probability: Homework	229
15	More Probability	251
16	More Probability: Homework	265
17	Markov Chains	277
18	Markov Chains: Homework	291
19	Game Theory	305
20	Game Theory: Homework	315
21	Practice Exam	327
	Glossary	335
	Index	336
	Attributions	337

Chapter 1

Linear Equations¹

1.1 Chapter Overview

In this chapter, you will learn to:

1. Graph a linear equation.
2. Find the slope of a line.
3. Determine an equation of a line.
4. Solve linear systems.
5. Do application problems using linear equations.

1.2 Graphing a Linear Equation

Equations whose graphs are straight lines are called **linear equations**. The following are some examples of linear equations:

$$2x - 3y = 6, 3x = 4y - 7, y = 2x - 5, 2y = 3, \text{ and } x - 2 = 0.$$

A line is completely determined by two points, therefore, to graph a linear equation, we need to find the coordinates of two points. This can be accomplished by choosing an arbitrary value for x or y and then solving for the other variable.

Example 1.1

Graph the line: $y = 3x + 2$

Solution

We need to find the coordinates of at least two points.

We arbitrarily choose $x = -1$, $x = 0$, and $x = 1$.

If $x = -1$, then $y = 3(-1) + 2$ or -1 . Therefore, $(-1, -1)$ is a point on this line.

If $x = 0$, then $y = 3(0) + 2$ or $y = 2$. Hence the point $(0, 2)$.

If $x = 1$, then $y = 5$, and we get the point $(1, 5)$. Below, the results are summarized, and the line is graphed.

X	-1	0	1
Y	-1	2	5

Table 1.1

¹This content is available online at <<http://cnx.org/content/m18901/1.2/>>.

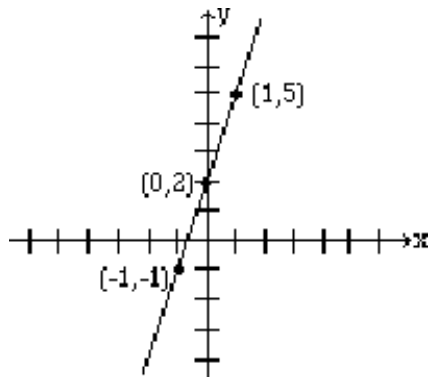

Figure 1.1

Example 1.2

Graph the line: $2x + y = 4$

Solution

Again, we need to find coordinates of at least two points.

We arbitrarily choose $x = -1$, $x = 0$ and $y = 2$.

If $x = -1$, then $2(-1) + y = 4$ which results in $y = 6$. Therefore, $(-1, 6)$ is a point on this line.

If $x = 0$, then $2(0) + y = 4$, which results in $y = 4$. Hence the point $(0, 4)$.

If $y = 2$, then $2x + 2 = 4$, which yields $x = 1$, and gives the point $(1, 2)$. The table below shows the points, and the line is graphed.

x	-1	0	1
y	6	4	2

Table 1.2

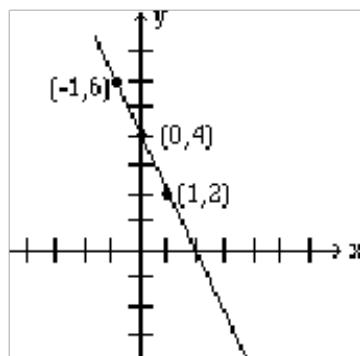

Figure 1.2

The points at which a line crosses the coordinate axes are called the **intercepts**. When graphing a line, intercepts are preferred because they are easy to find. In order to find the x-intercept, we let $y = 0$, and to find the y-intercept, we let $x = 0$.

Example 1.3

Find the intercepts of the line: $2x - 3y = 6$, and graph.

Solution

To find the x-intercept, we let $y = 0$ in our equation, and solve for x .

$$2x - 3(0) = 6 \quad (1.1)$$

$$2x - 0 = 6 \quad (1.2)$$

$$2x = 6 \quad (1.3)$$

$$x = 3 \quad (1.4)$$

Therefore, the x-intercept is 3.

Similarly by letting $x = 0$, we obtain the y-intercept which is -2.

NOTE: If the x-intercept is 3, and the y-intercept is -2, then the corresponding points are (3, 0) and (0, -2), respectively.

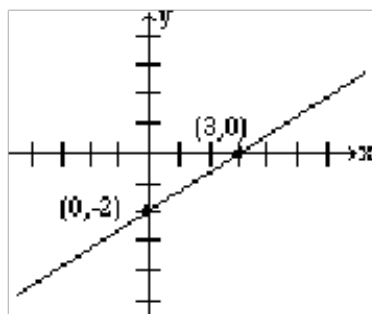

Figure 1.3

In higher math, equations of lines are sometimes written in parametric form. For example, $x = 3 + 2t$, $y = 1 + t$. The letter t is called the parameter or the dummy variable. Parametric lines can be graphed by finding values for x and y by substituting numerical values for t .

Example 1.4

Graph the line given by the parametric equations: $x = 3 + 2t$, $y = 1 + t$

Solution

Let $t = 0, 1$ and 2 , and then for each value of t find the corresponding values for x and y .

The results are given in the table below.

t	0	1	2
x	3	5	7
y	1	2	3

Table 1.3

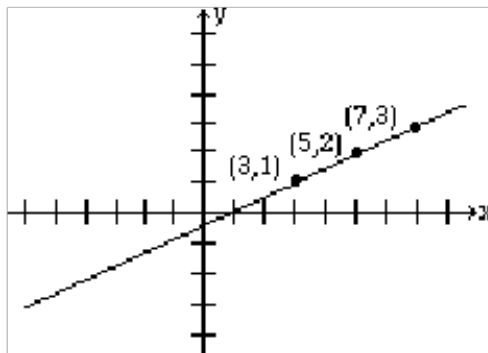

Figure 1.4

1.2.1 Horizontal and Vertical Lines

When an equation of a line has only one variable, the resulting graph is a horizontal or a vertical line.

The graph of the line $x = a$, where a is a constant, is a vertical line that passes through the point $(a, 0)$. Every point on this line has the x-coordinate a , regardless of the y-coordinate.

The graph of the line $y = b$, where b is a constant, is a horizontal line that passes through the point $(0, b)$. Every point on this line has the y-coordinate b , regardless of the x-coordinate.

Example 1.5

Graph the lines: $x = -2$, and $y = 3$.

Solution

The graph of the line $x = -2$ is a vertical line that has the x-coordinate -2 no matter what the y-coordinate is. Therefore, the graph is a vertical line passing through $(-2, 0)$.

The graph of the line $y = 3$, is a horizontal line that has the y-coordinate 3 regardless of what the x-coordinate is. Therefore, the graph is a horizontal line that passes through $(0, 3)$.

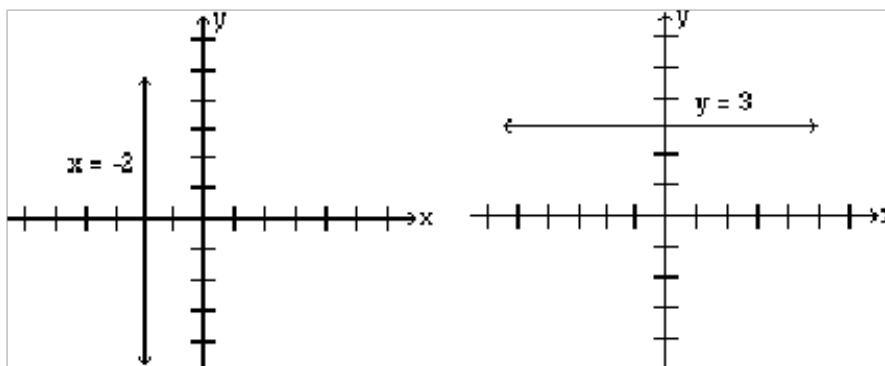

Figure 1.5

NOTE: Most students feel that the coordinates of points must always be integers. This is not true, and in real life situations, not always possible. Do not be intimidated if your points include numbers that are fractions or decimals.

1.3 Slope of a Line

1.3.1 Section Overview

In this section, you will learn to:

1. Find the slope of a line if two points are given.
2. Graph the line if a point and the slope are given.
3. Find the slope of the line that is written in the form $y = mx + b$.
4. Find the slope of the line that is written in the form $Ax + By = c$.

In the last section, we learned to graph a line by choosing two points on the line. A graph of a line can also be determined if one point and the "steepness" of the line is known. The precise number that refers to the steepness or inclination of a line is called the **slope** of the line.

From previous math courses, many of you remember slope as the "rise over run," or "the vertical change over the horizontal change" and have often seen it expressed as:

$$\frac{\text{rise}}{\text{run}}, \frac{\text{vertical change}}{\text{horizontal change}}, \frac{\Delta y}{\Delta x} \text{ etc.} \quad (1.5)$$

We give a precise definition.

Definition 1.1:

If (x_1, y_1) and (x_2, y_2) are two different points on a line, then the slope of the line is

$$\text{Slope} = m = \frac{y_2 - y_1}{x_2 - x_1}$$

Example 1.6

Find the slope of the line that passes through the points $(-2, 3)$ and $(4, -1)$, and graph the line.

Solution

Let $(x_1, y_1) = (-2, 3)$ and $(x_2, y_2) = (4, -1)$ then the slope

$$m = \frac{-1 - 3}{4 - (-2)} = -\frac{4}{6} = -\frac{2}{3} \quad (1.6)$$

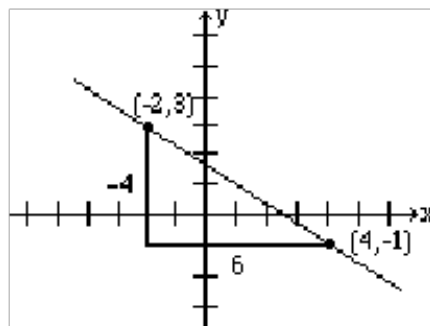

Figure 1.6

To give the reader a better understanding, both the vertical change, -4 , and the horizontal change, 6 , are shown in the above figure.

When two points are given, it does not matter which point is denoted as (x_1, y_1) and which (x_2, y_2) . The value for the slope will be the same. For example, if we choose $(x_1, y_1) = (4, -1)$ and $(x_2, y_2) = (-2, 3)$, we will get the same value for the slope as we obtained earlier. The steps involved are as follows.

$$m = \frac{3 - (-1)}{-2 - 4} = \frac{4}{-6} = -\frac{2}{3} \quad (1.7)$$

The student should further observe that if a line rises when going from left to right, then it has a positive slope; and if it falls going from left to right, it has a negative slope.

Example 1.7

Find the slope of the line that passes through the points $(2, 3)$ and $(2, -1)$, and graph.

Solution

Let $(x_1, y_1) = (2, 3)$ and $(x_2, y_2) = (2, -1)$ then the slope

$$m = \frac{-1 - 3}{2 - 2} = -\frac{4}{0} = \text{undefined} \quad (1.8)$$

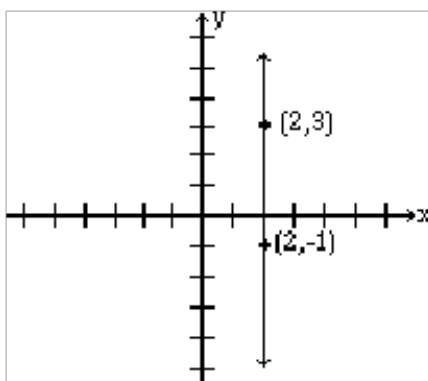

Figure 1.7

NOTE: The slope of a vertical line is undefined.

Example 1.8

Graph the line that passes through the point $(1, 2)$ and has slope $-\frac{3}{4}$.

Solution

Slope equals $\frac{\text{rise}}{\text{run}}$. The fact that the slope is $-\frac{3}{4}$, means that for every rise of -3 units (fall of 3 units) there is a run of 4. So if from the given point $(1, 2)$ we go down 3 units and go right 4 units, we reach the point $(5, -1)$. The following graph is obtained by connecting these two points.

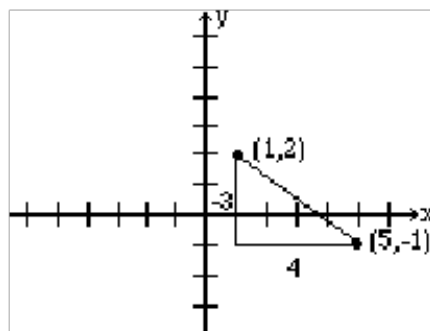

Figure 1.8

Alternatively, since $\frac{3}{-4}$ represents the same number, the line can be drawn by starting at the point (1,2) and choosing a rise of 3 units followed by a run of -4 units. So from the point (1, 2), we go up 3 units, and to the left 4, thus reaching the point $(-3, 5)$ which is also on the same line. See figure below.

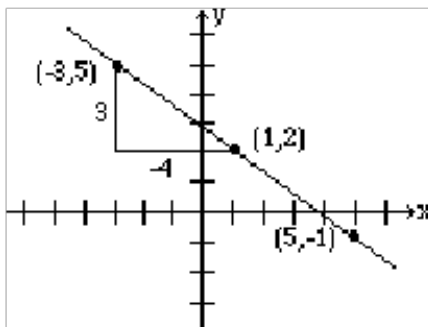

Figure 1.9

Example 1.9

Find the slope of the line $2x + 3y = 6$.

Solution

In order to find the slope of this line, we will choose any two points on this line.

Again, the selection of x and y intercepts seems to be a good choice. The x -intercept is $(3, 0)$, and the y -intercept is $(0, 2)$. Therefore, the slope is

$$m = \frac{2 - 0}{0 - 3} = -\frac{2}{3}. \quad (1.9)$$

The graph below shows the line and the intercepts: x and y .

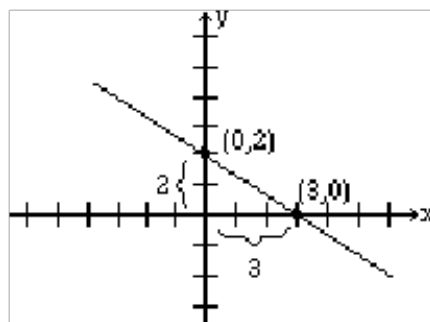

Figure 1.10

Example 1.10

Find the slope of the line $y = 3x + 2$.

Solution

We again find two points on the line. Say $(0, 2)$ and $(1, 5)$.

Therefore, the slope is $m = \frac{5-2}{1-0} = \frac{3}{1} = 3$.

Look at the slopes and the y-intercepts of the following lines.

The line	Slope	y-intercept
$y = 3x + 2$	3	2
$y = -2x + 5$	-2	5
$y = 3/2x - 4$	$3/2$	-4

Table 1.4

It is no coincidence that when an equation of the line is solved for y , the coefficient of the x term represents the slope, and the constant term represents the y-intercept.

In other words, for the line $y = mx + b$, m is the slope, and b is the y-intercept.

Example 1.11

Determine the slope and y-intercept of the line $2x + 3y = 6$.

Solution

We solve for y .

$$2x + 3y = 6 \quad (1.10)$$

$$3y = -2x + 6 \quad (1.11)$$

$$y = -2/3x + 2 \quad (1.12)$$

The slope = the coefficient of the x term = $-2/3$

The y-intercept = the constant term = 2.

1.4 Determining the Equation of a Line

1.4.1 Section Overview

In this section, you will learn to:

1. Find an equation of a line if a point and the slope are given.
2. Find an equation of a line if two points are given.

So far, we were given an equation of a line and were asked to give information about it. For example, we were asked to find points on it, find its slope and even find intercepts. Now we are going to reverse the process. That is, we will be given either two points, or a point and the slope of a line, and we will be asked to find its equation.

An equation of a line can be written in two forms, the **slope-intercept form** or the **standard form**.

The Slope-Intercept Form of a Line: $y = mx + b$

A line is completely determined by two points, or a point and slope. So it makes sense to ask to find the equation of a line if one of these two situations is given.

Example 1.12

Find an equation of a line whose slope is 5, and y-intercept is 3.

Solution

In the last section we learned that the equation of a line whose slope = m and y-intercept = b is $y = mx + b$.

Since $m = 5$, and $b = 3$, the equation is $y = 5x + 3$.

Example 1.13

Find the equation of the line that passes through the point (2, 7) and has slope 3.

Solution

Since $m = 3$, the partial equation is $y = 3x + b$.

Now b can be determined by substituting the point (2, 7) in the equation $y = 3x + b$.

$$7 = 3(2) + b \quad (1.13)$$

$$b = 1 \quad (1.14)$$

Therefore, the equation is $y = 3x + 1$.

Example 1.14

Find an equation of the line that passes through the points $(-1, 2)$, and $(1, 8)$.

Solution

$$m = \frac{8 - 2}{1 - (-1)} = \frac{6}{2} = 3 \quad (1.15)$$

So the partial equation is $y = 3x + b$

Now we can use either of the two points $(-1, 2)$ or $(1, 8)$, to determine b .

Substituting $(-1, 2)$ gives

$$2 = 3(-1) + b \quad (1.16)$$

$$5 = b \quad (1.17)$$

So the equation is $y = 3x + 5$.

Example 1.15

Find an equation of the line that has x-intercept 3, and y-intercept 4.

Solution

x-intercept = 3, and y-intercept = 4 correspond to the points $(3, 0)$, and $(0, 4)$, respectively.

$$m = \frac{4 - 0}{0 - 3} = \frac{4}{-3} \quad (1.18)$$

So the partial equation for the line is $y = -4/3x + b$

Substituting $(0, 4)$ gives

$$4 = -4/3(0) + b \quad (1.19)$$

$$4 = b \quad (1.20)$$

Therefore, the equation is $y = -4/3x + 4$.

The Standard form of a Line: $Ax + By = C$

Another useful form of the equation of a line is the Standard form.

Let L be a line with slope m , and containing a point (x_1, y_1) . If (x, y) is any other point on the line L , then by the definition of a slope, we get

$$m = \frac{y - y_1}{x - x_1} \quad (1.21)$$

$$y - y_1 = m(x - x_1) \quad (1.22)$$

The last result is referred to as the **point-slope form** or point-slope formula. If we simplify this formula, we get the equation of the line in the standard form, $Ax + By = C$.

Example 1.16

Using the point-slope formula, find the standard form of an equation of the line that passes through the point $(2, 3)$ and has slope $-3/5$.

Solution

Substituting the point $(2, 3)$ and $m = -3/5$ in the point-slope formula, we get

$$y - 3 = -3/5(x - 2) \quad (1.23)$$

Multiplying both sides by 5 gives us

$$5(y - 3) = -3/5(x - 2) \quad (1.24)$$

$$5y - 15 = -3x + 6 \quad (1.25)$$

$$3x + 5y = 21 \quad (1.26)$$

Example 1.17

Find the standard form of the line that passes through the points $(1, -2)$, and $(4, 0)$.

Solution

$$m = \frac{0 - (-2)}{4 - 1} = \frac{2}{3} \quad (1.27)$$

The point-slope form is

$$y - (-2) = 2/3(x - 1) \quad (1.28)$$

Multiplying both sides by 3 gives us

$$3(y + 2) = 2(x - 1) \quad (1.29)$$

$$3y + 6 = 2x - 2 \quad (1.30)$$

$$-2x + 3y = -8 \quad (1.31)$$

$$2x - 3y = 8 \quad (1.32)$$

We should always be able to convert from one form of an equation to another. That is, if we are given a line in the slope-intercept form, we should be able to express it in the standard form, and vice versa.

Example 1.18

Write the equation $y = -2/3x + 3$ in the standard form.

Solution

Multiplying both sides of the equation by 3, we get

$$3y = -2x + 9 \quad (1.33)$$

$$2x + 3y = 9 \quad (1.34)$$

Example 1.19

Write the equation $3x - 4y = 10$ in the slope-intercept form.

Solution

Solving for y , we get

$$-4y = -3x + 10 \quad (1.35)$$

$$y = 3/4x - 5/2 \quad (1.36)$$

Finally, we learn a very quick and easy way to write an equation of a line in the standard form. But first we must learn to find the slope of a line in the standard form by inspection.

By solving for y , it can easily be shown that the slope of the line $Ax + By = C$ is $-A/B$. The reader should verify.

Example 1.20

Find the slope of the following lines, by inspection.

- a. $3x - 5y = 10$
- b. $2x + 7y = 20$
- c. $4x - 3y = 8$

Solution

- a. $A = 3$, $B = -5$, therefore, $m = -\frac{3}{-5} = \frac{3}{5}$
- b. $A = 2$, $B = 7$, therefore, $m = -\frac{2}{7}$
- c. $m = -\frac{4}{-3} = \frac{4}{3}$

Now that we know how to find the slope of a line in the standard form by inspection, our job in finding the equation of a line is going to be very easy.

Example 1.21

Find an equation of the line that passes through $(2, 3)$ and has slope $-4/5$.

Solution

Since the slope of the line is $-4/5$, we know that the left side of the equation is $4x + 5y$, and the partial equation is going to be

$$4x + 5y = c \quad (1.37)$$

Of course, c can easily be found by substituting for x and y .

$$4(2) + 5(3) = c \quad (1.38)$$

$$23 = c \quad (1.39)$$

The desired equation is

$$4x + 5y = 23. \quad (1.40)$$

If you use this method often enough, you can do these problems very quickly.

1.5 Applications

Now that we have learned to determine equations of lines, we get to apply these ideas in real-life equations.

Example 1.22

A taxi service charges \$0.50 per mile plus a \$5 flat fee. What will be the cost of traveling 20 miles? What will be cost of traveling x miles?

Solution

$$\text{The cost of traveling 20 miles} = y = (.50)(20) + 5 = 10 + 5 = 15 \quad (1.41)$$

$$\text{The cost of traveling } x \text{ miles} = y = (.50)(x) + 5 = .50x + 5 \quad (1.42)$$

In this problem, \$0.50 per mile is referred to as the **variable cost**, and the flat charge \$5 as the **fixed cost**. Now if we look at our cost equation $y = .50x + 5$, we can see that the variable cost corresponds to the slope and the fixed cost to the y-intercept.

Example 1.23

The variable cost to manufacture a product is \$10 and the fixed cost \$2500. If x represents the number of items manufactured and y the total cost, write the cost function.

Solution

The fact that the variable cost represents the slope and the fixed cost represents the y-intercept, makes $m = 10$ and $y = 2500$.

Therefore, the cost equation is $y = 10x + 2500$.

Example 1.24

It costs \$750 to manufacture 25 items, and \$1000 to manufacture 50 items. Assuming a linear relationship holds, find the cost equation, and use this function to predict the cost of 100 items.

Solution

We let x = the number of items manufactured, and let y = the cost.

Solving this problem is equivalent to finding an equation of a line that passes through the points (25, 750) and (50, 1000).

$$m = \frac{1000-750}{50-25} = 10$$

Therefore, the partial equation is $y = 10x + b$

By substituting one of the points in the equation, we get $b = 500$

Therefore, the cost equation is $y = 10x + 500$

Now to find the cost of 100 items, we substitute $x = 100$ in the equation $y = 10x + 500$

So the cost = $y = 10(100) + 500 = 1500$

Example 1.25

The freezing temperature of water in Celsius is 0 degrees and in Fahrenheit 32 degrees. And the boiling temperatures of water in Celsius, and Fahrenheit are 100 degrees, and 212 degrees, respectively. Write a conversion equation from Celsius to Fahrenheit and use this equation to convert 30 degrees Celsius into Fahrenheit.

Solution

Let us look at what is given.

Centigrade	Fahrenheit
0	32
100	212

Table 1.5

Again, solving this problem is equivalent to finding an equation of a line that passes through the points (0, 32) and (100, 212).

Since we are finding a linear relationship, we are looking for an equation $y = mx + b$, or in this case $F = mC + b$, where x or C represent the temperature in Celsius, and y or F the temperature in Fahrenheit.

$$\text{slope } m = \frac{212 - 32}{100 - 0} = \frac{9}{5} \quad (1.43)$$

The equation is $F = \frac{9}{5}C + b$

Substituting the point (0, 32), we get

$$F = \frac{9}{5}C + 32. \quad (1.44)$$

Now to convert 30 degrees Celsius into Fahrenheit, we substitute $C = 30$ in the equation

$$F = \frac{9}{5}C + 32 \quad (1.45)$$

$$F = \frac{9}{5}(30) + 32 = 86 \quad (1.46)$$

Example 1.26

The population of Canada in the year 1970 was 18 million, and in 1986 it was 26 million. Assuming the population growth is linear, and x represents the year and y the population, write the function that gives a relationship between the time and the population. Use this equation to predict the population of Canada in 2010.

Solution

The problem can be made easier by using 1970 as the base year, that is, we choose the year 1970 as the year zero. This will mean that the year 1986 will correspond to year 16, and the year 2010 as the year 40.

Now we look at the information we have.

Solving this problem is equivalent to finding an equation of a line that passes through the points $(0, 18)$ and $(16, 26)$.

$$m = \frac{26 - 18}{16 - 0} = \frac{1}{2} \quad (1.47)$$

The equation is $y = \frac{1}{2}x + b$

Substituting the point $(0, 18)$, we get

$$y = \frac{1}{2}x + 18 \quad (1.48)$$

Now to find the population in the year 2010, we let $x = 40$ in the equation

$$y = \frac{1}{2}x + 18 \quad (1.49)$$

$$y = \frac{1}{2}(40) + 18 = 38 \quad (1.50)$$

So the population of Canada in the year 2010 will be 38 million.

Year	Population
0 (1970)	18 million
16 (1986)	26 million

Table 1.6

1.6 More Applications

1.6.1 Section Overview

In this section, you will learn to:

1. Solve a linear system in two variables.
2. Find the equilibrium point when a demand and a supply equation are given.

3. Find the break-even point when the revenue and the cost functions are given.

In this section, we will do application problems that involve the intersection of lines. Therefore, before we proceed any further, we will first learn how to find the intersection of two lines.

Example 1.27

Find the intersection of the line $y = 3x - 1$ and the line $y = -x + 7$.

Solution

We graph both lines on the same axes, as shown below, and read the solution $(2, 5)$.

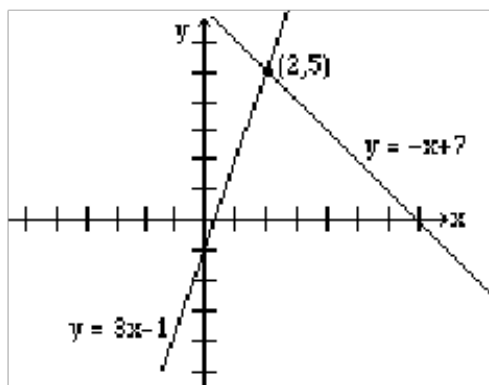

Figure 1.11

Finding an intersection of two lines graphically is not always easy or practical; therefore, we will now learn to solve these problems algebraically.

At the point where two lines intersect, the x and y values for both lines are the same. So in order to find the intersection, we either let the x -values or the y -values equal.

If we were to solve the above example algebraically, it will be easier to let the y -values equal. Since $y = 3x - 1$ for the first line, and $y = -x + 7$ for the second line, by letting the y -values equal, we get

$$\begin{aligned} 3x - 1 &= -x + 7 \\ 4x &= 8 \\ x &= 2 \end{aligned} \tag{1.51}$$

By substituting $x = 2$ in any of the two equations, we obtain $y = 5$.

Hence, the solution $(2, 5)$.

One common algebraic method used in solving systems of equations is called the **elimination method**. The object of this method is to eliminate one of the two variables by adding the left and right sides of the equations together. Once one variable is eliminated, we get an equation that has

only one variable for which it can be solved. Finally, by substituting the value of the variable that has been found in one of the original equations, we get the value of the other variable. The method is demonstrated in the example below.

Example 1.28

Find the intersection of the lines $2x + y = 7$ and $3x - y = 3$ by the elimination method.

Solution

We add the left and right sides of the two equations.

$$\begin{array}{r} 2x + y = 7 \\ 3x - y = 3 \\ \hline 5x = 10 \end{array} \quad (1.52)$$

$$x = 2 \quad (1.53)$$

Now we substitute $x = 2$ in any of the two equations and solve for y .

$$2(2) + y = 7 \quad (1.54)$$

$$y = 3 \quad (1.55)$$

Therefore, the solution is $(2, 3)$.

Example 1.29

Solve the system of equations $x + 2y = 3$ and $2x + 3y = 4$ by the elimination method.

Solution

If we add the two equations, none of the variables are eliminated. But the variable x can be eliminated by multiplying the first equation by -2 , and leaving the second equation unchanged.

$$\begin{array}{r} -2x - 4y = -6 \\ 2x + 3y = 4 \\ \hline -y = -2 \end{array} \quad (1.56)$$

$$y = 2 \quad (1.57)$$

Substituting $y = 2$ in $x + 2y = 3$, we get

$$x + 2(2) = 3 \quad (1.58)$$

$$x = -1 \quad (1.59)$$

Therefore, the solution is $(-1, 2)$.

Example 1.30

Solve the system of equations $3x - 4y = 5$ and $4x - 5y = 6$.

Solution

This time, we multiply the first equation by -4 and the second by 3 before adding. (The choice of numbers is not unique.)

$$\begin{aligned} -12x + 16y &= -20 \\ 12x - 15y &= 18 \\ y &= -2 \end{aligned} \tag{1.60}$$

By substituting $y = -2$ in any one of the equations, we get $x = -1$. Hence the solution $(-1, -2)$.

Supply, Demand and the Equilibrium Market Price

In a free market economy the supply curve for a commodity is the number of items of a product that can be made available at different prices, and the demand curve is the number of items the consumer will buy at different prices. As the price of a product increases, its demand decreases and supply increases. On the other hand, as the price decreases the demand increases and supply decreases. The **equilibrium price** is reached when the demand equals the supply.

Example 1.31

The supply curve for a product is $y = 1.5x + 10$ and the demand curve for the same product is $y = -2.5x + 34$, where x is the price and y the number of items produced. Find the following.

- How many items will be supplied at a price of \$10?
- How many items will be demanded at a price of \$10?
- Determine the equilibrium price.
- How many items will be produced at the equilibrium price?

Solution

- We substitute $x = 10$ in the supply equation, $y = 1.5x + 10$, and the answer is $y = 25$.
- We substitute $x = 10$ in the demand equation, $y = -2.5x + 34$, and the answer is $y = 9$.
- By letting the supply equal the demand, we get

$$1.5x + 10 = -2.5x + 34 \tag{1.61}$$

$$4x = 24 \tag{1.62}$$

$$x = 6 \tag{1.63}$$

- We substitute $x = 6$ in either the supply or the demand equation and we get $y = 19$. The graph below shows the intersection of the supply and the demand functions and their point of intersection, $(6, 19)$.

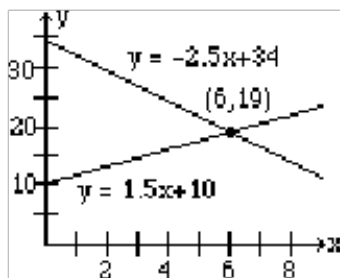

Figure 1.12

Break-Even Point

In a business, the profit is generated by selling products. If a company sells x number of items at a price P , then the revenue R is P times x , i.e., $R = P \cdot x$. The production costs are the sum of the variable costs and the fixed costs, and are often written as $C = mx + b$, where x is the number of items manufactured.

A company makes a profit if the revenue is greater than the cost, and it shows a loss if the cost is greater than the revenue. The point on the graph where the revenue equals the cost is called the **Break-even point**.

Example 1.32

If the revenue function of a product is $R = 5x$ and the cost function is $y = 3x + 12$, find the following.

- If 4 items are produced, what will the revenue be?
- What is the cost of producing 4 items?
- How many items should be produced to break-even?
- What will be the revenue and the cost at the break-even point?

Solution

- We substitute $x = 4$ in the revenue equation $R = 5x$, and the answer is $R = 20$.
- We substitute $x = 4$ in the cost equation $C = 3x + 12$, and the answer is $C = 24$.
- By letting the revenue equal the cost, we get

$$5x = 3x + 12 \tag{1.64}$$

$$x = 6 \tag{1.65}$$

- d. We substitute $x = 6$ in either the revenue or the cost equation, and we get $R = C = 30$.
The graph below shows the intersection of the revenue and the cost functions and their point of intersection, $(6, 30)$.

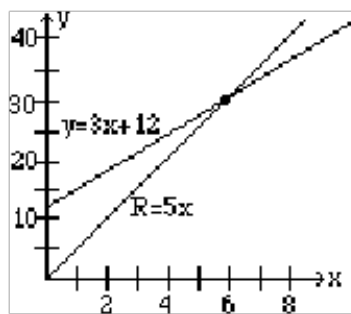

Figure 1.13

Chapter 2

Linear Equations: Homework¹

2.1 GRAPHING A LINEAR EQUATION

Work the following problems.

Exercise 2.1

Is the point $(2, 3)$ on the line $5x - 2y = 4$?

(Solution on p. 34.)

Exercise 2.2

Is the point $(1, -2)$ on the line $6x - y = 4$?

Exercise 2.3

For the line $3x - y = 12$, complete the following ordered pairs.

$(2,)$ $(, 6)$

$(0,)$ $(, 0)$

(Solution on p. 34.)

Exercise 2.4

For the line $4x + 3y = 24$, complete the following ordered pairs.

$(3,)$ $(, 4)$

$(0,)$ $(, 0)$

Exercise 2.5

Graph $y = 2x + 3$

(Solution on p. 34.)

Exercise 2.6

Graph $y = -3x + 5$

Exercise 2.7

Graph $y = 4x - 3$

(Solution on p. 34.)

Exercise 2.8

Graph $x - 2y = 8$

Exercise 2.9

Graph $2x + y = 4$

(Solution on p. 34.)

Exercise 2.10

Graph $2x - 3y = 6$

Exercise 2.11

Graph $2x + 4 = 0$

(Solution on p. 35.)

Exercise 2.12

Graph $2y - 6 = 0$

¹This content is available online at <http://cnx.org/content/m38636/1.2/>.

Exercise 2.13*(Solution on p. 35.)*

Graph the following three equations on the same set of coordinate axes.

$$y = x + 1 \quad y = 2x + 1 \quad y = -x + 1 \quad (2.1)$$

Exercise 2.14

Graph the following three equations on the same set of coordinate axes.

$$y = 2x + 1 \quad y = 2x \quad y = 2x - 1 \quad (2.2)$$

Exercise 2.15*(Solution on p. 36.)*

Graph the line using the parametric equations

$$x = 1 + 2t, \quad y = 3 + t \quad (2.3)$$

Exercise 2.16

Graph the line using the parametric equations

$$x = 2 - 3t, \quad y = 1 + 2t \quad (2.4)$$

2.2 SLOPE OF A LINE

Find the slope of the line passing through the following pair of points.

Exercise 2.17

(2, 3) and (5, 9)

*(Solution on p. 36.)***Exercise 2.18**

(4, 1) and (2, 5)

Exercise 2.19

(-1, 1) and (1, 3)

*(Solution on p. 36.)***Exercise 2.20**

(4, 3) and (-1, 3)

Exercise 2.21

(6, -5) and (4, -1)

*(Solution on p. 36.)***Exercise 2.22**

(5, 3) and (-1, -4)

Exercise 2.23

(3, 4) and (3, 7)

*(Solution on p. 36.)***Exercise 2.24**

(-2, 4) and (-3, -2)

Exercise 2.25

(-3, -5) and (-1, -7)

*(Solution on p. 36.)***Exercise 2.26**

(0, 4) and (3, 0)

Determine the slope of the line from the given equation of the line.

Exercise 2.27*(Solution on p. 37.)*

$$y = -2x + 1 \quad (2.5)$$

Exercise 2.28

$$y = 3x - 2$$

Exercise 2.29*(Solution on p. 37.)*

$$2x - y = 6 \quad (2.6)$$

Exercise 2.30

$$x + 3y = 6 \quad (2.7)$$

Exercise 2.31*(Solution on p. 37.)*

$$3x - 4y = 12 \quad (2.8)$$

Exercise 2.32

What is the slope of the x-axis? How about the y-axis?

Graph the line that passes through the given point and has the given slope.

Exercise 2.33(1, 2) and $m = -3/4$ *(Solution on p. 37.)***Exercise 2.34**(2, -1) and $m = 2/3$ **Exercise 2.35**(0, 2) and $m = -2$ *(Solution on p. 37.)***Exercise 2.36**(2, 3) and $m = 0$

2.3 DETERMINING THE EQUATION OF A LINE

Write an equation of the line satisfying the following conditions. Write the equation in the form $y = mx + b$.**Exercise 2.37**

It passes through the point (3, 10) and has slope = 2.

*(Solution on p. 37.)***Exercise 2.38**It passes through the point (4,5) and has $m = 0$.**Exercise 2.39**

It passes through (3, 5) and (2, -1).

*(Solution on p. 37.)***Exercise 2.40**

It has slope 3, and its y-intercept equals 2.

Exercise 2.41It passes through (5, -2) and $m = 2/5$.*(Solution on p. 38.)***Exercise 2.42**

It passes through (-5, -3) and (10, 0).

Exercise 2.43 *(Solution on p. 38.)*

It passes through $(4, -4)$ and $(5, 3)$.

Exercise 2.44

It passes through $(7, -2)$ and its y -intercept is 5.

Exercise 2.45

It passes through $(2, -5)$ and its x -intercept is 4.

(Solution on p. 38.)

Exercise 2.46

Its a horizontal line through the point $(2, -1)$.

Exercise 2.47

It passes through $(5, -4)$ and $(1, -4)$.

(Solution on p. 38.)

Exercise 2.48

It is a vertical line through the point $(3, -2)$.

Exercise 2.49

It passes through $(3, -4)$ and $(3, 4)$.

(Solution on p. 38.)

Exercise 2.50

It has x -intercept = 3 and y -intercept = 4.

Write an equation of the line satisfying the following conditions. Write the equation in the form $Ax + By = C$.

Exercise 2.51

It passes through $(3, -1)$ and $m = 2$.

(Solution on p. 38.)

Exercise 2.52

It passes through $(-2, 1)$ and $m = -3/2$.

Exercise 2.53

It passes through $(-4, -2)$ and $m = 3/4$.

(Solution on p. 38.)

Exercise 2.54

Its x -intercept equals 3, and $m = -5/3$.

Exercise 2.55

It passes through $(2, -3)$ and $(5, 1)$.

(Solution on p. 38.)

Exercise 2.56

It passes through $(1, -3)$ and $(-5, 5)$.

2.4 APPLICATIONS

In the following application problems, assume a linear relationship holds.

Exercise 2.57

(Solution on p. 38.)

The variable cost to manufacture a product is \$25, and the fixed costs are \$1200. If x represents the number of items manufactured and y the cost, write the cost function.

Exercise 2.58

It costs \$90 to rent a car driven 100 miles and \$140 for one driven 200 miles. If x is the number of miles driven and y the total cost of the rental, write the cost function.

Exercise 2.59

(Solution on p. 38.)

The variable cost to manufacture an item is \$20, and it costs a total of \$750 to produce 20 items. If x represents the number of items manufactured and y the cost, write the cost function.

Exercise 2.60

To manufacture 30 items, it costs \$2700, and to manufacture 50 items, it costs \$3200. If x represents the number of items manufactured and y the cost, write the cost function.

Exercise 2.61*(Solution on p. 38.)*

To manufacture 100 items, it costs \$32,000, and to manufacture 200 items, it costs \$40,000. If x represents the number of items manufactured and y the cost, write the cost function.

Exercise 2.62

It costs \$1900 to manufacture 60 items, and the fixed costs are \$700. If x represents the number of items manufactured and y the cost, write the cost function.

Exercise 2.63*(Solution on p. 38.)*

A person who weighs 150 pounds has 60 pounds of muscles, and a person that weighs 180 pounds has 72 pounds of muscles. If x represents the body weight and y the muscle weight, write an equation describing their relationship. Use this relationship to determine the muscle weight of a person that weighs 170 pounds.

Exercise 2.64

A spring on a door stretches 6 inches if a force of 30 pounds is applied, and it stretches 10 inches if a force of 50 pounds is applied. If x represents the number of inches stretched, and y the force applied, write an equation describing the relationship. Use this relationship to determine the amount of force required to stretch the spring 12 inches.

Exercise 2.65*(Solution on p. 38.)*

A male college student who is 64 inches tall weighs 110 pounds, and another student who is 74 inches tall weighs 180 pounds. Assuming the relationship between male students' heights (x), and weights (y) is linear, write a function to express weights in terms of heights, and use this function to predict the weight of a student who is 68 inches tall.

Exercise 2.66

EZ Clean company has determined that if it spends \$30,000 on advertisement, it can hope to sell 12,000 of its Minivacs a year, but if it spends \$50,000, it can sell 16,000. Write an equation that gives a relationship between the number of dollars spent on advertisement (x) and the number of minivacs sold (y).

Exercise 2.67*(Solution on p. 38.)*

The freezing temperatures for Celsius and Fahrenheit scales are 0 degree and 32 degrees, respectively. The boiling temperatures for Celsius and Fahrenheit are 100 degrees and 212 degrees, respectively. Let C denote the temperature in Celsius and F in Fahrenheit. Write the conversion function from Celsius to Fahrenheit, and use this function to convert 25 degrees Celsius into an equivalent Fahrenheit measure.

Exercise 2.68

By reversing the coordinates in the previous problem, find a conversion function that converts Fahrenheit into Celsius, and use this conversion function to convert 72 degrees Fahrenheit into an equivalent Celsius measure.

Exercise 2.69*(Solution on p. 38.)*

The population of California in the year 1960 was 17 million, and in 1995 it was 32 million. Write the population function, and use this function to find the population of California in the year 2010. (Hint: Use the year 1960 as the base year, that is, assume 1960 as the year zero. This will make 1995, and 2010 as the years 35, and 50, respectively.)

Exercise 2.70

In the U. S. the number of people infected with the HIV virus in 1985 was 1,000, and in 1995 that number became 350,000. If the increase in the number is linear, write an equation that will give the number of people infected in any year. If this trend continues, what will the number be in 2010? (Hint: See previous problem.)

Exercise 2.71*(Solution on p. 38.)*

In 1975, an average house in San Jose cost \$45,000 and the same house in 1995 costs \$195,000. Write an equation that will give the price of a house in any year, and use this equation to predict the price of a similar house in the year 2010.

Exercise 2.72

An average math text book cost \$25 in 1980, and \$60 in 1995. Write an equation that will give the price of a math book in any given year, and use this equation to predict the price of the book in 2010.

2.5 MORE APPLICATIONS

Solve the following problems.

Exercise 2.73*(Solution on p. 38.)*

Solve for x and y .

$$y = 3x + 4$$

$$y = 5x - 2$$

Exercise 2.74

Solve for x and y .

$$2x - 3y = 4$$

$$3x - 4y = 5$$

Exercise 2.75*(Solution on p. 38.)*

The supply curve for a product is $y = 2000x + 13000$, and the demand curve is $y = -1000x + 28000$, where x represents the price and y the number of items. At what price will the supply equal demand, and how many items will be produced at that price?

Exercise 2.76

The supply curve for a product is $y = 300x + 9000$, and the demand curve is $y = -100x + 14000$, where x represents the price and y the number of items. At what price will the supply equal demand, and how many items will be produced at that price?

Exercise 2.77*(Solution on p. 38.)*

A demand curve for a commodity is the number of items the consumer will buy at different prices. It has been determined that at a price of \$2 a store can sell 2400 of a particular type of toy dolls, and for a price of \$8 the store can sell 600 such dolls. If x represents the price of dolls and y the number of items sold, write an equation for the demand curve.

Exercise 2.78

A supply curve for a commodity is the number of items of the product that can be made available at different prices. A manufacturer of toy dolls can supply 2000 dolls if the dolls are sold for \$8 each, but he can supply only 800 dolls if the dolls are sold for \$2 each. If x represents the price of dolls and y the number of items, write an equation for the supply curve.

Exercise 2.79*(Solution on p. 39.)*

The equilibrium price is the price where the supply equals the demand. From the demand and supply curves obtained in the previous two problems, find the equilibrium price, and determine the number of items that can be sold at that price.

Exercise 2.80

A car rental company offers two plans. Plan I charges \$10 a day and 10 cents a mile, while Plan II charges 14 cents a mile, but no flat fee. If you were to drive 300 miles in a day, which plan is better? For what mileage are both rates equal?

Exercise 2.81*(Solution on p. 39.)*

A break-even point is the intersection of the cost function and the revenue function, that is, where the total cost equals revenue. Mrs. Jones Cookies Store's revenue and cost in dollars for x number of cookies is given by $R = .80x$ and $C = .05x + 3000$. Find the number of cookies that must be sold so that the revenue and cost are the same.

Exercise 2.82

A company's revenue and cost in dollars are given by $R = 225x$ and $C = 75x + 6000$, where x is the number of items. Find the number of items that must be produced to break-even.

Exercise 2.83*(Solution on p. 39.)*

A firm producing computer diskettes has a fixed costs of \$10,725, and variable cost of 20 cents a diskette. Find the break-even point if the diskettes sell for \$1.50 each.

Exercise 2.84

Whackemhard Sports is planning to introduce a new line of tennis rackets. The fixed costs for the new line are \$25,000 and the variable cost of producing each racket is \$60. If the racket sells for \$80, find the number of rackets that must be sold in order to break even.

2.6 CHAPTER REVIEW**Exercise 2.85***(Solution on p. 39.)*

Find an equation of the x-axis.

Exercise 2.86*(Solution on p. 39.)*

Find the slope of the line whose equation is $2x + 3y = 6$.

Exercise 2.87*(Solution on p. 39.)*

Find the slope of the line whose equation is $y = -3x + 5$.

Exercise 2.88*(Solution on p. 39.)*

Find both the x and y intercepts of the line $3x - 2y = 12$.

Exercise 2.89*(Solution on p. 39.)*

Find an equation of the line whose slope is 3 and y-intercept 5.

Exercise 2.90*(Solution on p. 39.)*

Find an equation of the line whose x-intercept is 2 and y-intercept 3.

Exercise 2.91*(Solution on p. 39.)*

Find an equation of the line that has slope 3 and passes through the point (2, 15).

Exercise 2.92*(Solution on p. 39.)*

Find an equation of the line that has slope $-\frac{3}{2}$ and passes through the point (4, 3).

Exercise 2.93*(Solution on p. 39.)*

Find an equation of the line that passes through the points (0, 32) and (100, 212).

Exercise 2.94*(Solution on p. 39.)*

Find an equation of the line that passes through the point (2, 5) and is parallel to the line $y = 3x + 4$.

Exercise 2.95*(Solution on p. 39.)*

Find the point of intersection of the lines $2x - 3y = 9$ and $3x + 4y = 5$.

Exercise 2.96*(Solution on p. 39.)*

Is the point (3, -2) on the line $5x - 2y = 11$?

Exercise 2.97*(Solution on p. 39.)*

Find two points on the line given by the parametric equations, $x = 2 + 3t$, $y = 1 - 2t$.

Exercise 2.98*(Solution on p. 39.)*

Find two points on the line $2x - 6 = 0$.

Exercise 2.99 (Solution on p. 39.)

Graph the line $2x - 3y + 6 = 0$.

Exercise 2.100 (Solution on p. 40.)

Graph the line $y = -2x + 3$.

Exercise 2.101 (Solution on p. 40.)

A female college student who is 60 inches tall weighs 100 pounds, and another female student who is 66 inches tall weighs 124 pounds. Assuming the relationship between the female students' weights and heights is linear, write an equation giving the relationship between heights and weights of female students, and use this relationship to predict the weight of a female student who is 70 inches tall.

Exercise 2.102 (Solution on p. 40.)

In deep-sea diving, the pressure exerted by water plays a great role in designing underwater equipment. If at a depth of 10 feet there is a pressure of 21 lb/in², and at a depth of 50 ft there is a pressure of 75 lb/in², write an equation giving a relationship between depth and pressure. Use this relationship to predict pressure at a depth of 100 ft.

Exercise 2.103 (Solution on p. 40.)

If the variable cost to manufacture an item is \$30, and the fixed costs are \$2750, write the cost function.

Exercise 2.104 (Solution on p. 40.)

The variable cost to manufacture an item is \$10, and it costs \$2,500 to produce 100 items. Write the cost function, and use this function to estimate the cost of manufacturing 300 items.

Exercise 2.105 (Solution on p. 40.)

It costs \$2,700 to manufacture 100 items of a product, and \$4,200 to manufacture 200 items. If x represents the number of items, and y the costs, find the cost equation, and use this function to predict the cost of 1,000 items.

Exercise 2.106 (Solution on p. 40.)

In 1980, the average house in Palo Alto cost \$280,000 and the same house in 1997 costs \$450,000. Assuming a linear relationship, write an equation that will give the price of the house in any year, and use this equation to predict the price of a similar house in the year 2010.

Exercise 2.107 (Solution on p. 40.)

The population of Argentina in 1987 was 31.5 million and in 1997 it was 42.5 million. Assuming a linear relationship, write an equation that will give the population of Argentina in any year, and use this equation to predict the population of Argentina in the year 2010.

Exercise 2.108 (Solution on p. 40.)

In 1955, an average new Chevrolet sold for \$2,400, and a similar Chevrolet sold for \$15,000 in 1995. Assuming a linear relationship, write an equation that will give the price of an average Chevrolet in any year. Use this equation to predict the price of an average Chevrolet in the year 2010.

Exercise 2.109 (Solution on p. 40.)

Two-hundred items are demanded at a price of \$5, and 300 items are demanded at a price of \$3. If x represents the price, and y the number of items, write the demand function.

Exercise 2.110 (Solution on p. 40.)

A supply curve for a product is the number of items of the product that can be made available at different prices. A manufacturer of Tickle Me Elmo dolls can supply 2000 dolls if the dolls are sold for \$30 each, but he can supply only 800 dolls if the dolls are sold for \$10 each. If x represents the price of dolls and y the number of items, write an equation for the supply curve.

Exercise 2.111 (Solution on p. 40.)

Suppose you are trying to decide on a price for your latest creation - a coffee mug that never tips. Through a survey, you have determined that at a price of \$2, you can sell 2100 mugs, but at a price

of \$12 you can only sell 100 mugs. Furthermore, your supplier can supply you 3500 mugs if you charge your customers \$12, but only 500 if you charge \$2. What price should you charge so that the supply equals demand, and at that price how many coffee mugs will you be able to sell?

Exercise 2.112 *(Solution on p. 40.)*

A car rental company offers two plans. Plan I charges \$12 a day and 12 cents a mile, while Plan II charges \$30 a day but no charge for miles. If you were to drive 300 miles in a day, which plan is better? For what mileage are both rates the same?

Exercise 2.113 *(Solution on p. 40.)*

The supply curve for a product is $y = 250x - 1,000$ and the demand curve for the same product is $y = -350x + 8,000$, where x is the price and y the number of items produced. Find the following.

- At a price of \$10, how many items will be in demand?
- At what price will 4,000 items be supplied?
- What is the equilibrium price for this product?
- How many items will be manufactured at the equilibrium price?

Exercise 2.114 *(Solution on p. 41.)*

The supply curve for a product is $y = 625x - 600$ and the demand curve for the same product is $y = -125x + 8,400$, where x is the price and y the number of items produced. Find the equilibrium price and determine the number of items that will be produced at that price.

Exercise 2.115 *(Solution on p. 41.)*

Both Jenny and Masur are sales people for Athletic Shoes. Jenny gets paid \$8 per hour plus 4% commission on the sales. Masur gets paid \$10 per hour plus 8% commission on the sales in excess of \$1,000. If they work 8-hour days, for what sales amount would they both earn the same daily amounts?

Exercise 2.116 *(Solution on p. 41.)*

A company's revenue and cost in dollars are given by $R = 25x$ and $C = 10x + 9,000$, where x represents the number of items. Find the number of items that must be produced to break-even.

Exercise 2.117 *(Solution on p. 41.)*

A firm producing video tapes has fixed costs of \$6,800, and a variable cost of 30 cents per tape. If the video tapes sell for \$2 each, find the number of tapes that must be produced to break-even.

Exercise 2.118 *(Solution on p. 41.)*

A firm producing disposable cameras has fixed costs of \$8,000, and variable cost of 50 cents a camera. If the cameras sell for \$3.50, how many cameras must be produced to break-even?

Exercise 2.119 *(Solution on p. 41.)*

The Stanley Company is coming up with a new cordless travel shaver just before the Christmas holidays. It hopes to sell 10,000 of these shavers in the month of December alone. The manufacturing variable cost is \$3 and the fixed costs \$100,000. If the shavers sell for \$11 each, how many must be produced to break-even?

Solutions to Exercises in Chapter 2

Solutions to Linear Equations: Homework

Solution to Exercise 2.1 (p. 25)

Yes

Solution to Exercise 2.3 (p. 25)

(2, -6) (6, 6)

(0, -12) (4, 0)

Solution to Exercise 2.5 (p. 25)

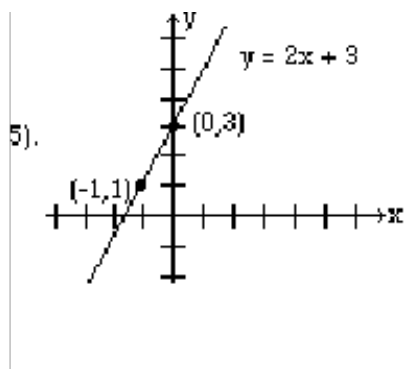

Figure 2.1

Solution to Exercise 2.7 (p. 25)

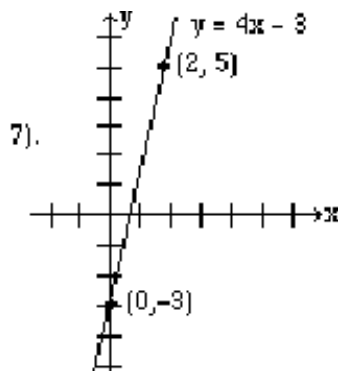

Figure 2.2

Solution to Exercise 2.9 (p. 25)

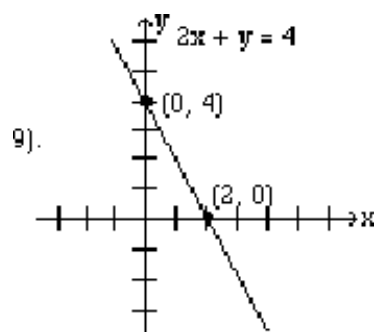

Figure 2.3

Solution to Exercise 2.11 (p. 25)

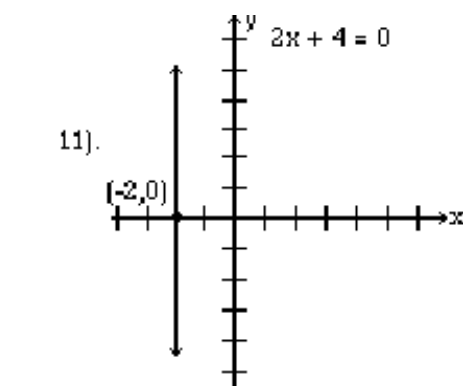

Figure 2.4

Solution to Exercise 2.13 (p. 26)

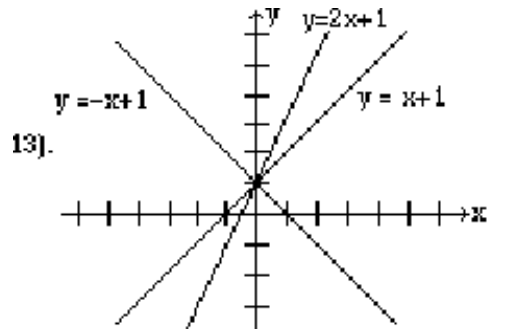

Figure 2.5

Solution to Exercise 2.15 (p. 26)

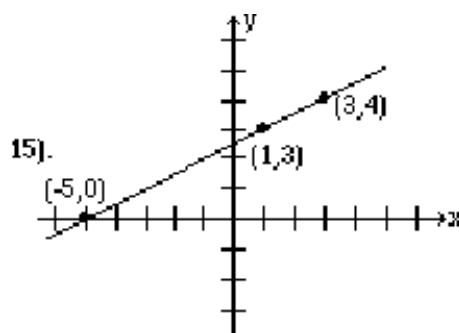

Figure 2.6

Solution to Exercise 2.17 (p. 26)

$$m = 2 \quad (2.9)$$

Solution to Exercise 2.19 (p. 26)

$$m = 1 \quad (2.10)$$

Solution to Exercise 2.21 (p. 26)

$$m = -2 \quad (2.11)$$

Solution to Exercise 2.23 (p. 26)

$$m = \text{undefined} \quad (2.12)$$

Solution to Exercise 2.25 (p. 26)

$$m = -1 \quad (2.13)$$

Solution to Exercise 2.27 (p. 26)

$$m = -2 \quad (2.14)$$

Solution to Exercise 2.29 (p. 27)

$$m = 2 \quad (2.15)$$

Solution to Exercise 2.31 (p. 27)

$$m = 3/4 \quad (2.16)$$

Solution to Exercise 2.33 (p. 27)

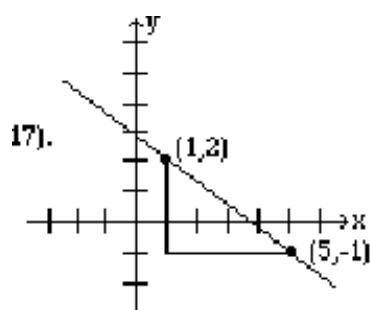

Figure 2.7

Solution to Exercise 2.35 (p. 27)

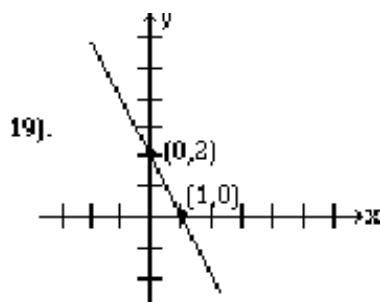

Figure 2.8

Solution to Exercise 2.37 (p. 27)

$$y = 2x + 4 \quad (2.17)$$

Solution to Exercise 2.39 (p. 27)

$$y = 6x - 13 \quad (2.18)$$

Solution to Exercise 2.41 (p. 27)

$$y = 2/5x - 4 \quad (2.19)$$

Solution to Exercise 2.43 (p. 28)

$$y = 7x - 32 \quad (2.20)$$

Solution to Exercise 2.45 (p. 28)

$$y = 5/2x - 10 \quad (2.21)$$

Solution to Exercise 2.47 (p. 28)

$$y = -4 \quad (2.22)$$

Solution to Exercise 2.49 (p. 28)

$$x = 3 \quad (2.23)$$

Solution to Exercise 2.51 (p. 28)

$$2x - y = 7 \quad (2.24)$$

Solution to Exercise 2.53 (p. 28)

$$3x - 4y = -4 \quad (2.25)$$

Solution to Exercise 2.55 (p. 28)

$$4x - 3y = 17 \quad (2.26)$$

Solution to Exercise 2.57 (p. 28)

$$y = 25x + 1200 \quad (2.27)$$

Solution to Exercise 2.59 (p. 28)

$$y = 20x + 350 \quad (2.28)$$

Solution to Exercise 2.61 (p. 29)

$$y = 80x + 24000 \quad (2.29)$$

Solution to Exercise 2.63 (p. 29)

$$y = 2/5x; 68$$

Solution to Exercise 2.65 (p. 29)

$$y = 7x - 338; 138$$

Solution to Exercise 2.67 (p. 29)

$$F = 9/5C + 32; 77^{\circ}\text{F}$$

Solution to Exercise 2.69 (p. 29)

$$y = 3/7x + 17; 38.43$$

Solution to Exercise 2.71 (p. 30)

$$y = 7500x + 45000; \$307,500$$

Solution to Exercise 2.73 (p. 30)

$$x = 3, y = 13$$

Solution to Exercise 2.75 (p. 30)

$$x = 5, y = 23000$$

Solution to Exercise 2.77 (p. 30)

$$y = -300x + 3000 \quad (2.30)$$

Solution to Exercise 2.79 (p. 30)

$$x = 5.2 \quad y = 1440 \quad (2.31)$$

Solution to Exercise 2.81 (p. 31)

$$x = 4000 \quad (2.32)$$

Solution to Exercise 2.83 (p. 31)
(8250, 12375)

Solution to Exercise 2.85 (p. 31)

$$y = 0 \quad (2.33)$$

Solution to Exercise 2.86 (p. 31)

$$-2/3 \quad (2.34)$$

Solution to Exercise 2.87 (p. 31)
-3

Solution to Exercise 2.88 (p. 31)
4, -6

Solution to Exercise 2.89 (p. 31)

$$y = 3x + 5 \quad (2.35)$$

Solution to Exercise 2.90 (p. 31)

$$3x + 2y = 6 \quad (2.36)$$

Solution to Exercise 2.91 (p. 31)

$$y = 3x + 9 \quad (2.37)$$

Solution to Exercise 2.92 (p. 31)

$$3x + 2y = 18 \quad (2.38)$$

Solution to Exercise 2.93 (p. 31)

$$y = 9/5x + 32 \quad (2.39)$$

Solution to Exercise 2.94 (p. 31)

$$y = 3x - 1 \quad (2.40)$$

Solution to Exercise 2.95 (p. 31)
(3, -1)

Solution to Exercise 2.96 (p. 31)
No

Solution to Exercise 2.97 (p. 31)
(2,1), (5,-1); Answers will vary

Solution to Exercise 2.98 (p. 31)
(3,0), (3, 1); Answers will vary

Solution to Exercise 2.99 (p. 32)The line through $(-3,0)$ and $(0,2)$ **Solution to Exercise 2.100 (p. 32)**The line through $(0,3)$ and $(1,1)$ **Solution to Exercise 2.101 (p. 32)**

$$y = 4x - 140; 140 \quad (2.41)$$

Solution to Exercise 2.102 (p. 32)

$$y = 1.35x + 15.2; 142.5 \quad (2.42)$$

Solution to Exercise 2.103 (p. 32)

$$y = 30x + 2750 \quad (2.43)$$

Solution to Exercise 2.104 (p. 32)

$$y = 10x + 1500; 4500 \quad (2.44)$$

Solution to Exercise 2.105 (p. 32)

$$y = 15x + 1200; 16200 \quad (2.45)$$

Solution to Exercise 2.106 (p. 32)

$$y = 10000x + 280000; 580000 \quad (2.46)$$

Solution to Exercise 2.107 (p. 32)

$$y = 1.1x + 31.5; 56.8 \quad (2.47)$$

Solution to Exercise 2.108 (p. 32)

$$y = 315x + 2400; 19725 \quad (2.48)$$

Solution to Exercise 2.109 (p. 32)

$$y = -50x + 450 \quad (2.49)$$

Solution to Exercise 2.110 (p. 32)

$$y = 60x + 200 \quad (2.50)$$

Solution to Exercise 2.111 (p. 32)

$$\text{Price} = \$5.20; \# \text{ of mugs} = 1460 \quad (2.51)$$

Solution to Exercise 2.112 (p. 33)

150 miles

Solution to Exercise 2.113 (p. 33)

- a. 4500;
- b. 20;
- c. 15;
- d. 2750

Solution to Exercise 2.114 (p. 33)

\$12; 6900

Solution to Exercise 2.115 (p. 33)

1600

Solution to Exercise 2.116 (p. 33)

600

Solution to Exercise 2.117 (p. 33)

4,000

Solution to Exercise 2.118 (p. 33)

2,667

Solution to Exercise 2.119 (p. 33)

12,500

Chapter 3

Matrices¹

3.1 Chapter Overview

In this chapter, you will learn to:

1. Do matrix operations.
2. Solve linear systems using the Gauss-Jordan method.
3. Solve linear systems using the matrix inverse method.
4. Do application problems.

3.2 Introduction to Matrices

3.2.1 Section Overview

In this section you will learn to:

1. Add and subtract matrices.
2. Multiply a matrix by a scalar.
3. Multiply two matrices.

A matrix is a rectangular array of numbers. Matrices are useful in organizing and manipulating large amounts of data. In order to get some idea of what matrices are all about, we will look at the following example.

Example 3.1

Fine Furniture Company makes chairs and tables at its San Jose, Hayward, and Oakland factories. The total production, in hundreds, from the three factories for the years 1994 and 1995 is listed in the table below.

	1994		1995	
	Chairs	Tables	Chairs	Tables
<i>continued on next page</i>				

¹This content is available online at <<http://cnx.org/content/m18902/1.2/>>.

San Jose	30	18	36	20
Hayward	20	12	24	18
Oakland	16	10	20	12

Table 3.1

- Represent the production for the years 1994 and 1995 as the matrices A and B .
- Find the difference in sales between the years 1994 and 1995.
- The company predicts that in the year 2000 the production at these factories will double that of the year 1994. What will the production be for the year 2000?

Solution

a. The matrices are as follows: $A = \begin{bmatrix} 30 & 18 \\ 20 & 12 \\ 16 & 10 \end{bmatrix}$ $B = \begin{bmatrix} 36 & 20 \\ 24 & 18 \\ 20 & 12 \end{bmatrix}$

- b. We are looking for the matrix $B - A$. When two matrices have the same number of rows and columns, the matrices can be added or subtracted entry by entry. Therefore, we get

$$B - A = \begin{bmatrix} 36 - 30 & 20 - 18 \\ 24 - 20 & 18 - 12 \\ 20 - 16 & 12 - 10 \end{bmatrix} = \begin{bmatrix} 6 & 2 \\ 4 & 6 \\ 4 & 2 \end{bmatrix} \quad (3.1)$$

- c. We would like a matrix that is twice the matrix of 1994, i.e., $2A$.
Whenever a matrix is multiplied by a number, each entry is multiplied by the number.

$$2A = 2 \begin{bmatrix} 30 & 18 \\ 20 & 12 \\ 16 & 10 \end{bmatrix} = \begin{bmatrix} 60 & 36 \\ 40 & 24 \\ 32 & 20 \end{bmatrix} \quad (3.2)$$

Before we go any further, we need to familiarize ourselves with some terms that are associated with matrices. The numbers in a matrix are called the **entries** or the **elements** of a matrix. Whenever we talk about a matrix, we need to know the **size** or the **dimension** of the matrix. The dimension of a matrix is the number of rows and columns it has. When we say a matrix is a 3 by 4 matrix, we are saying that it has 3 rows and 4 columns. The rows are always mentioned first and the columns second. This means that a 3×4 matrix does not have the same dimension as a 4×3 matrix. A matrix that has the same number of rows as columns is called a **square matrix**. A matrix with all entries zero is called a **zero matrix**. A square matrix with 1's along the main diagonal and zeros everywhere else, is called an **identity matrix**. When a square matrix is multiplied by an identity matrix of same size, the matrix remains the same. A matrix with only one row is called a row matrix or a **row vector**, and a matrix with only one column is called a column matrix or a **column vector**. Two matrices are **equal** if they have the same size and the corresponding entries are equal.

Matrix Addition and Subtraction

If two matrices have the same size, they can be added or subtracted. The operations are performed on corresponding entries.

Example 3.2

Given the matrices A , B , C and D , below

$$A = \begin{bmatrix} 1 & 2 & 4 \\ 2 & 3 & 1 \\ 5 & 0 & 3 \end{bmatrix} \quad B = \begin{bmatrix} 2 & -1 & 3 \\ 2 & 4 & 2 \\ 3 & 6 & 1 \end{bmatrix} \quad C = \begin{bmatrix} 4 \\ 2 \\ 3 \end{bmatrix} \quad D = \begin{bmatrix} -2 \\ -3 \\ 4 \end{bmatrix} \quad (3.3)$$

Find, if possible.

- $A + B$
- $C - D$
- $A + D$.

Solution

As we mentioned earlier, matrix addition and subtraction involves performing these operations entry by entry.

- We add each element of A to the corresponding entry of B .

$$A + B = \begin{bmatrix} 3 & 1 & 7 \\ 4 & 7 & 3 \\ 8 & 6 & 4 \end{bmatrix} \quad (3.4)$$

- Just like the problem above, we perform the subtraction entry by entry.

$$C - D = \begin{bmatrix} 6 \\ 5 \\ -1 \end{bmatrix} \quad (3.5)$$

- The sum $A + D$ cannot be found because the two matrices have different sizes.

NOTE: Two matrices can only be added or subtracted if they have the same dimension.

Multiplying a Matrix by a Scalar

If a matrix is multiplied by a scalar (a constant number), each entry is multiplied by that scalar.

Example 3.3

Given the matrix A and C in Example 3.2, find $2A$ and $-3C$.

Solution

To find $2A$, we multiply each entry of matrix A by 2, and to find $-3C$, we multiply each entry of C by -3 . The results are given below.

- We multiply each entry of A by 2.

$$2A = \begin{bmatrix} 2 & 4 & 8 \\ 4 & 6 & 2 \\ 10 & 0 & 6 \end{bmatrix} \quad (3.6)$$

b. We multiply each entry of C by -3 .

$$-3C = \begin{bmatrix} -12 \\ -6 \\ -9 \end{bmatrix} \quad (3.7)$$

Multiplication of Two Matrices

To multiply a matrix by another is not as easy as the addition, subtraction, or scalar multiplication of matrices. Because of its wide use in application problems, it is important that we learn it well. Therefore, we will try to learn the process in a step by step manner. We first begin by finding a product of a row matrix and a column matrix.

Example 3.4

Given $A = \begin{bmatrix} 2 & 3 & 4 \end{bmatrix}$ and $B = \begin{bmatrix} a \\ b \\ c \end{bmatrix}$, find the product AB .

Solution

The product is a 1×1 matrix whose entry is obtained by multiplying the corresponding entries and then forming the sum.

$$AB = \begin{bmatrix} 2 & 3 & 4 \end{bmatrix} \begin{bmatrix} a \\ b \\ c \end{bmatrix} = [(2a + 3b + 4c)] \quad (3.8)$$

Note that AB is a 1×1 matrix, and its only entry is $2a + 3b + 4c$.

Example 3.5

Given $A = \begin{bmatrix} 2 & 3 & 4 \end{bmatrix}$ and $B = \begin{bmatrix} 5 \\ 6 \\ 7 \end{bmatrix}$, find the product AB .

Solution

Again, we multiply the corresponding entries and add.

$$\begin{aligned} AB &= \begin{bmatrix} 2 & 3 & 4 \end{bmatrix} \begin{bmatrix} 5 \\ 6 \\ 7 \end{bmatrix} \\ &= [2 \cdot 5 + 3 \cdot 6 + 4 \cdot 7] \\ &= [10 + 18 + 28] \\ &= [56] \end{aligned} \quad (3.9)$$

NOTE: In order for a product of a row matrix and a column matrix to exist, the number of entries in the row matrix must be the same as the number of entries in the column matrix.

Example 3.6

Given $A = \begin{bmatrix} 2 & 3 & 4 \end{bmatrix}$ and $B = \begin{bmatrix} 5 & 3 \\ 6 & 4 \\ 7 & 5 \end{bmatrix}$, find the product AB .

Solution

We already know how to multiply a row matrix by a column matrix. To find the product AB , in this example, we will be multiplying the row matrix A to both the first and second columns of matrix B , resulting in a 1×2 matrix.

$$AB = \begin{bmatrix} 2 \cdot 5 + 3 \cdot 6 + 4 \cdot 7 & 2 \cdot 3 + 3 \cdot 4 + 4 \cdot 5 \end{bmatrix} = \begin{bmatrix} 56 & 38 \end{bmatrix} \quad (3.10)$$

We have just multiplied a 1×3 matrix by a matrix whose size is 3×2 . So unlike addition and subtraction, it is possible to multiply two matrices with different dimensions as long as the number of entries in the rows of the first matrix are the same as the number of entries in columns of the second matrix.

Example 3.7

Given $A = \begin{bmatrix} 2 & 3 & 4 \\ 1 & 2 & 3 \end{bmatrix}$ and $B = \begin{bmatrix} 5 & 3 \\ 6 & 4 \\ 7 & 5 \end{bmatrix}$, find the product AB .

Solution

This time we are multiplying two rows of the matrix A with two columns of the matrix B . Since the number of entries in each row of A are the same as the number of entries in each column of B , the product is possible. We do exactly what we did in Example 3.6. The only difference is that the matrix A has one more row.

We multiply the first row of the matrix A with the two columns of B , one at a time, and then repeat the process with the second row of A . We get

$$\begin{aligned} AB &= \begin{bmatrix} 2 & 3 & 4 \\ 1 & 2 & 3 \end{bmatrix} \begin{bmatrix} 5 & 3 \\ 6 & 4 \\ 7 & 5 \end{bmatrix} \\ &= \begin{bmatrix} 2 \cdot 5 + 3 \cdot 6 + 4 \cdot 7 & 2 \cdot 3 + 3 \cdot 4 + 4 \cdot 5 \\ 1 \cdot 5 + 2 \cdot 6 + 3 \cdot 7 & 1 \cdot 3 + 2 \cdot 4 + 3 \cdot 5 \end{bmatrix} \\ &= \begin{bmatrix} 56 & 38 \\ 38 & 26 \end{bmatrix} \end{aligned} \quad (3.11)$$

Example 3.8

Given the matrices E , F , G and H , below

$$E = \begin{bmatrix} 1 & 2 \\ 4 & 2 \\ 3 & 1 \end{bmatrix} \quad F = \begin{bmatrix} 2 & -1 \\ 3 & 2 \end{bmatrix} \quad G = \begin{bmatrix} 4 & 1 \end{bmatrix} \quad H = \begin{bmatrix} -3 \\ -1 \end{bmatrix} \quad (3.12)$$

Find, if possible.

- EF
- FE
- FH
- GH

Solution

- a. To find EF, we multiply the first row $\begin{bmatrix} 1 & 2 \end{bmatrix}$ of E with the columns $\begin{bmatrix} 2 \\ 3 \end{bmatrix}$ and $\begin{bmatrix} -1 \\ 2 \end{bmatrix}$ of the matrix F , and then repeat the process by multiplying the other two rows of E with these columns of F . The result is as follows:

$$\begin{aligned} EF &= \begin{bmatrix} 1 & 2 \\ 4 & 2 \\ 3 & 1 \end{bmatrix} \begin{bmatrix} 2 & -1 \\ 3 & 2 \end{bmatrix} \\ &= \begin{bmatrix} 1 \cdot 2 + 2 \cdot 3 & 1 \cdot (-1) + 2 \cdot 2 \\ 4 \cdot 2 + 2 \cdot 3 & 4 \cdot (-1) + 2 \cdot 2 \\ 3 \cdot 2 + 1 \cdot 3 & 3 \cdot (-1) + 1 \cdot 2 \end{bmatrix} = \begin{bmatrix} 8 & 3 \\ 14 & 0 \\ 9 & -1 \end{bmatrix} \end{aligned} \quad (3.13)$$

- b. The product FE is not possible because the matrix F has two entries in each row, while the matrix E has three entries in each column. In other words, the matrix F has two columns, while the matrix E has three rows.

$$\text{c. } FH = \begin{bmatrix} 2 & -1 \\ 3 & 2 \end{bmatrix} \begin{bmatrix} -3 \\ -1 \end{bmatrix} = \begin{bmatrix} 2 \cdot (-3) + (-1) \cdot (-1) \\ 3 \cdot (-3) + 2 \cdot (-1) \end{bmatrix} = \begin{bmatrix} -5 \\ -11 \end{bmatrix}$$

$$\text{d. } GH = \begin{bmatrix} 4 & 1 \end{bmatrix} \begin{bmatrix} -3 \\ -1 \end{bmatrix} = [4 \cdot (-3) + 1 \cdot (-1)] = [-13]$$

We summarize matrix multiplication as follows:

In order for product AB to exist, the number of columns of A , must equal the number of rows of B . If matrix A is of dimension $m \times n$ and B of dimension $n \times p$, the product will have the dimension $m \times p$. Furthermore, matrix multiplication is not commutative.

Example 3.9

Given the matrices R , S , and T below.

$$R = \begin{bmatrix} 1 & 0 & 2 \\ 2 & 1 & 5 \\ 2 & 3 & 1 \end{bmatrix} \quad S = \begin{bmatrix} 0 & -1 & 2 \\ 3 & 1 & 0 \\ 4 & 2 & 1 \end{bmatrix} \quad T = \begin{bmatrix} -2 & 3 & 0 \\ -3 & 2 & 2 \\ -1 & 1 & 0 \end{bmatrix} \quad (3.14)$$

Find $2RS - 3ST$.

Solution

We multiply the matrices R and S .

$$RS = \begin{bmatrix} 8 & 3 & 4 \\ 23 & 9 & 9 \\ 13 & 3 & 5 \end{bmatrix} \quad (3.15)$$

$$2RS = 2 \begin{bmatrix} 8 & 3 & 4 \\ 23 & 9 & 9 \\ 13 & 3 & 5 \end{bmatrix} = \begin{bmatrix} 16 & 6 & 8 \\ 46 & 18 & 18 \\ 26 & 6 & 10 \end{bmatrix} \quad (3.16)$$

$$ST = \begin{bmatrix} 1 & 0 & -2 \\ -9 & 11 & 2 \\ -15 & 17 & 4 \end{bmatrix} \quad (3.17)$$

$$3ST = 3 \begin{bmatrix} 1 & 0 & -2 \\ -9 & 11 & 2 \\ -15 & 17 & 4 \end{bmatrix} = \begin{bmatrix} 3 & 0 & -6 \\ -27 & 33 & 6 \\ -45 & 51 & 12 \end{bmatrix} \quad (3.18)$$

$$2RS - 3ST = \begin{bmatrix} 16 & 6 & 8 \\ 46 & 18 & 18 \\ 26 & 6 & 10 \end{bmatrix} - \begin{bmatrix} 3 & 0 & -6 \\ -27 & 33 & 6 \\ -45 & 51 & 12 \end{bmatrix} = \begin{bmatrix} 13 & 6 & 14 \\ 73 & -15 & 12 \\ 71 & -45 & -2 \end{bmatrix} \quad (3.19)$$

In this chapter, we will be using matrices to solve linear systems. In Section 3.5 (Inverse Matrices), we will be asked to express linear systems as the **matrix equation** $AX = B$, where A , X , and B are matrices. The matrix A is called the **coefficient matrix**.

Example 3.10

Verify that the system of two linear equations with two unknowns:

$$ax + by = h \quad (3.20)$$

$$cx + dy = k \quad (3.21)$$

can be written as $AX = B$, where

$$A = \begin{bmatrix} a & b \\ c & d \end{bmatrix} \quad X = \begin{bmatrix} x \\ y \end{bmatrix} \quad \text{and} \quad B = \begin{bmatrix} h \\ k \end{bmatrix}$$

Solution

If we multiply the matrices A and X , we get

$$AX = \begin{bmatrix} a & b \\ c & d \end{bmatrix} \begin{bmatrix} x \\ y \end{bmatrix} = \begin{bmatrix} ax + by \\ cx + dy \end{bmatrix} \quad (3.22)$$

If $AX = B$ then

$$\begin{bmatrix} ax + by \\ cx + dy \end{bmatrix} = \begin{bmatrix} h \\ k \end{bmatrix} \quad (3.23)$$

If two matrices are equal, then their corresponding entries are equal. Therefore, it follows that

$$ax + by = h \quad (3.24)$$

$$cx + dy = k \quad (3.25)$$

Example 3.11

Express the following system as $AX = B$.

$$2x + 3y - 4z = 5 \quad (3.26)$$

$$3x + 4y - 5z = 6 \quad (3.27)$$

$$5x - 6z = 7 \quad (3.28)$$

Solution

The above system of equations can be expressed in the form $AX = B$ as shown below.

$$\begin{bmatrix} 2 & 3 & -4 \\ 3 & 4 & -5 \\ 5 & 0 & -6 \end{bmatrix} \begin{bmatrix} x \\ y \\ z \end{bmatrix} = \begin{bmatrix} 5 \\ 6 \\ 7 \end{bmatrix} \quad (3.29)$$

3.3 Systems of Linear Equations; Gauss-Jordan Method

In this section, we learn to solve systems of linear equations using a process called the Gauss-Jordan method. The process begins by first expressing the system as a matrix, and then reducing it to an equivalent system by simple row operations. The process is continued until the solution is obvious from the matrix. The matrix that represents the system is called the **augmented matrix**, and the arithmetic manipulation that is used to move from a system to a reduced equivalent system is called a **row operation**.

Example 3.12

Write the following system as an augmented matrix.

$$2x + 3y - 4z = 5 \quad (3.30)$$

$$3x + 4y - 5z = -6 \quad (3.31)$$

$$4x + 5y - 6z = 7 \quad (3.32)$$

Solution

We express the above information in matrix form. Since a system is entirely determined by its coefficient matrix and by its matrix of constant terms, the augmented matrix will include only the coefficient matrix and the constant matrix. So the augmented matrix we get is as follows:

$$\left[\begin{array}{ccc|c} 2 & 3 & -4 & 5 \\ 3 & 4 & -5 & -6 \\ 4 & 5 & -6 & 7 \end{array} \right] \quad (3.33)$$

In the Section 3.2 (Introduction to Matrices), we expressed the system of equations as $AX = B$, where A represented the coefficient matrix, and B the matrix of constant terms. As an augmented matrix, we write the matrix as $[A | B]$. It is clear that all of the information is maintained in this matrix form, and only the letters x , y and z are missing. A student may choose to write x , y and z on top of the first three columns to help ease the transition.

Example 3.13

For the following augmented matrix, write the system of equations it represents.

$$\left[\begin{array}{ccc|c} 1 & 3 & -5 & 2 \\ 2 & 0 & -3 & -5 \\ 3 & 2 & -3 & -1 \end{array} \right] \quad (3.34)$$

Solution

The system is readily obtained as below.

$$x + 3y - 5z = 2 \quad (3.35)$$

$$2x - 3z = -5 \quad (3.36)$$

$$3x + 2y - 3z = -1 \quad (3.37)$$

Once a system is expressed as an augmented matrix, the Gauss-Jordan method reduces the system into a series of equivalent systems by employing the row operations. This row reduction continues until the system is expressed in what is called the **reduced row echelon form**. The reduced row echelon form of the coefficient matrix has 1's along the main diagonal and zeros elsewhere. The solution is readily obtained from this form.

The method is not much different from the algebraic operations we employed in the elimination method in the first chapter. The basic difference is that it is algorithmic in nature, and, therefore, can easily be programmed on a computer.

We will next solve a system of two equations with two unknowns, using the elimination method, and then show that the method is analogous to the Gauss-Jordan method.

Example 3.14

Solve the following system by the elimination method.

$$x + 3y = 7 \tag{3.38}$$

$$3x + 4y = 11 \tag{3.39}$$

Solution

We multiply the first equation by -3 , and add it to the second equation.

$$\begin{array}{r} -3x - 9y = -21 \\ \underline{3x + 4y = 11} \\ -5y = -10 \end{array} \tag{3.40}$$

By doing this we have transformed our original system into an equivalent system as follows.

$$x + 3y = 7 \tag{3.41}$$

$$-5y = -10 \tag{3.42}$$

We divide the second equation by -5 , and we get the next equivalent system.

$$x + 3y = 7 \tag{3.43}$$

$$y = 2 \tag{3.44}$$

Now we multiply the second equation by -3 and add to the first, we get

$$x = 1 \tag{3.45}$$

$$y = 2 \tag{3.46}$$

Example 3.15

Solve the following system from Example 3.14 by the Gauss-Jordan method, and show the similarities in both methods by writing the equations next to the matrices.

$$x + 3y = 7 \tag{3.47}$$

$$3x + 4y = 11 \tag{3.48}$$

Solution

The augmented matrix for the system is as follows.

$$\left[\begin{array}{cc|c} 1 & 3 & 7 \\ 3 & 4 & 11 \end{array} \right] \left[\begin{array}{l} x + 3y = 7 \\ 3x + 4y = 11 \end{array} \right] \quad (3.49)$$

We multiply the first row by -3 , and add to the second row.

$$\left[\begin{array}{cc|c} 1 & 3 & 7 \\ 0 & -5 & -10 \end{array} \right] \left[\begin{array}{l} x + 3y = 7 \\ -5y = -10 \end{array} \right] \quad (3.50)$$

We divide the second row by -5 , we get,

$$\left[\begin{array}{cc|c} 1 & 3 & 7 \\ 0 & 1 & 2 \end{array} \right] \left[\begin{array}{l} x + 3y = 7 \\ y = 2 \end{array} \right] \quad (3.51)$$

Finally, we multiply the second row by -3 and add to the first row, and we get,

$$\left[\begin{array}{cc|c} 1 & 0 & 1 \\ 0 & 1 & 2 \end{array} \right] \left[\begin{array}{l} x = 1 \\ y = 2 \end{array} \right] \quad (3.52)$$

Now we list the three row operations the Gauss-Jordan method employs.

3.16: Row Operations

1. Any two rows in the augmented matrix may be interchanged.
2. Any row may be multiplied by a non-zero constant.
3. A constant multiple of a row may be added to another row.

One can easily see that these three row operation may make the system look different, but they do not change the solution of the system.

The first row operation states that if any two rows of a system are interchanged, the new system obtained has the same solution as the old one. Let us look at an example in two equations with two unknowns. Consider the system

$$x + 3y = 7 \quad (3.53)$$

$$3x + 4y = 11 \quad (3.54)$$

We interchange the rows, and we get,

$$3x + 4y = 11 \quad (3.55)$$

$$x + 3y = 7 \quad (3.56)$$

Clearly, this system has the same solution as the one above.

The second operation states that if a row is multiplied by any non-zero constant, the new system obtained has the same solution as the old one. Consider the above system again,

$$x + 3y = 7 \quad (3.57)$$

$$3x + 4y = 11 \quad (3.58)$$

We multiply the first row by -3 , we get,

$$-3x - 9y = -21 \quad (3.59)$$

$$3x + 4y = 11 \quad (3.60)$$

Again, it is obvious that this new system has the same solution as the original.

The third row operation states that any constant multiple of one row added to another preserves the solution. Consider our system,

$$x + 3y = 7 \quad (3.61)$$

$$3x + 4y = 11 \quad (3.62)$$

If we multiply the first row by -3 , and add it to the second row, we get,

$$x + 3y = 7 \quad (3.63)$$

$$-5y = -10 \quad (3.64)$$

And once again, the same solution is maintained.

Now that we understand how the three row operations work, it is time to introduce the Gauss-Jordan method to solve systems of linear equations.

As mentioned earlier, the Gauss-Jordan method starts out with an augmented matrix, and by a series of row operations ends up with a matrix that is in the **reduced row echelon form**. A matrix is in the reduced row echelon form if the first nonzero entry in each row is a 1, and the columns containing these 1's have all other entries as zeros. The reduced row echelon form also requires that the leading entry in each row be to the right of the leading entry in the row above it, and the rows containing all zeros be moved down to the bottom.

We state the Gauss-Jordan method as follows.

3.17: Gauss-Jordan Method

1. Write the augmented matrix.
2. Interchange rows if necessary to obtain a non-zero number in the first row, first column.
3. Use a row operation to make the entry in the first row, first column, a 1.
4. Use row operations to make all other entries as zeros in column one.
5. Interchange rows if necessary to obtain a nonzero number in the second row, second column. Use a row operation to make this entry 1. Use row operations to make all other entries as zeros in column two.
6. Repeat step 5 for row 3, column 3. Continue moving along the main diagonal until you reach the last row, or until the number is zero. The final matrix is called the reduced row-echelon form.

Example 3.18

Solve the following system by the Gauss-Jordan method.

$$2x + y + 2z = 10 \quad (3.65)$$

$$x + 2y + z = 8 \quad (3.66)$$

$$3x + y - z = 2 \quad (3.67)$$

Solution

We write the augmented matrix.

$$\left[\begin{array}{ccc|c} 2 & 1 & 2 & 10 \\ 1 & 2 & 1 & 8 \\ 3 & 1 & -1 & 2 \end{array} \right] \quad (3.68)$$

We want a 1 in row one, column one. This can be obtained by dividing the first row by 2, or interchanging the second row with the first. Interchanging the rows is a better choice because that way we avoid fractions.

$$\left[\begin{array}{ccc|c} 1 & 2 & 1 & 8 \\ 2 & 1 & 2 & 10 \\ 3 & 1 & -1 & 2 \end{array} \right] \quad (3.69)$$

we interchanged row 1(R1) and row 2(R2)

We need to make all other entries zeros in column 1. To make the entry (2) a zero in row 2, column 1, we multiply row 1 by -2 and add it to the second row. We get,

$$\left[\begin{array}{ccc|c} 1 & 2 & 1 & 8 \\ 0 & -3 & 0 & -6 \\ 3 & 1 & -1 & 2 \end{array} \right] \quad -2R1 + R2 \quad (3.70)$$

To make the entry (3) a zero in row 3, column 1, we multiply row 1 by -3 and add it to the third row. We get,

$$\left[\begin{array}{ccc|c} 1 & 2 & 1 & 8 \\ 0 & -3 & 0 & -6 \\ 0 & -5 & -4 & -22 \end{array} \right] \quad -3R1 + R3 \quad (3.71)$$

So far we have made a 1 in the left corner and all other entries zeros in that column. Now we move to the next diagonal entry, row 2, column 2. We need to make this entry(-3) a 1 and make all other entries in this column zeros. To make row 2, column 2 entry a 1, we divide the entire second row by -3.

$$\left[\begin{array}{ccc|c} 1 & 2 & 1 & 8 \\ 0 & 1 & 0 & 2 \\ 0 & -5 & -4 & -22 \end{array} \right] \quad R2 \div (-3) \quad (3.72)$$

Next, we make all other entries zeros in the second column.

$$\left[\begin{array}{ccc|c} 1 & 0 & 1 & 4 \\ 0 & 1 & 0 & 2 \\ 0 & 0 & -4 & -12 \end{array} \right] \quad -2R2 + R1 \quad \text{and} \quad 5R2 + R3 \quad (3.73)$$

We make the last diagonal entry a 1, by dividing row 3 by -4 .

$$\left[\begin{array}{ccc|c} 1 & 0 & 1 & 4 \\ 0 & 1 & 0 & 2 \\ 0 & 0 & 1 & 3 \end{array} \right] \quad \text{R3} \div (-4) \quad (3.74)$$

Finally, we make all other entries zeros in column 3.

$$\left[\begin{array}{ccc|c} 1 & 0 & 0 & 1 \\ 0 & 1 & 0 & 2 \\ 0 & 0 & 1 & 3 \end{array} \right] \quad -\text{R3} + \text{R1} \quad (3.75)$$

Clearly, the solution reads $x = 1$, $y = 2$, and $z = 3$.

Before we leave this section, we mention some terms we may need in the fourth chapter. The process of obtaining a 1 in a location, and then making all other entries zeros in that column, is called **pivoting**. The number that is made a 1 is called the **pivot element**, and the row that contains the pivot element is called the **pivot row**. We often multiply the pivot row by a number and add it to another row to obtain a zero in the latter. The row to which a multiple of pivot row is added is called the **target row**.

3.4 Systems of Linear Equations – Special Cases

3.4.1 Section Overview

In this section you will learn to:

1. Determine the linear systems that have no solution.
2. Solve the linear systems that have infinitely many solutions.

If we consider the intersection of two lines in a plane, three things can happen.

1. The lines intersect in exactly one point. This is called **an independent system**.
2. The lines are parallel, so they do not intersect. This is called an **inconsistent system**.
3. The lines coincide, so they intersect at infinitely many points. This is a **dependent system**.

The figures below shows all three cases.

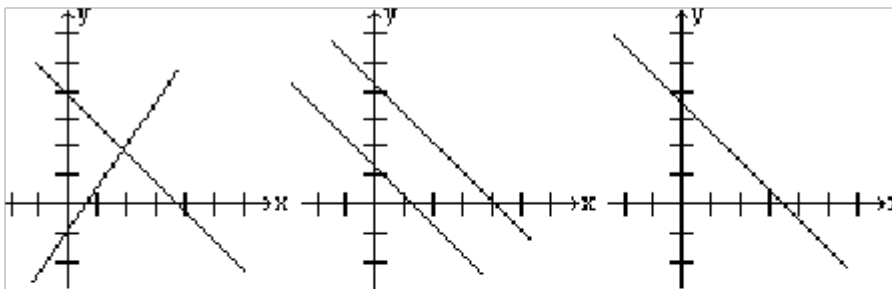

Figure 3.1

Every system of equations has either one solution, no solution, or infinitely many solutions.

In the Section 3.3 (Systems of Linear Equations; Gauss-Jordan Method), we used the Gauss-Jordan method to solve systems that had exactly one solution. In this section, we will determine the systems that have no solution, and solve the systems that have infinitely many solutions.

Example 3.19

Solve the following system of equations.

$$x + y = 7 \quad (3.76)$$

$$x + y = 9 \quad (3.77)$$

Solution

Let us use the Gauss-Jordan method to solve this system. The augmented matrix is as follows.

$$\left[\begin{array}{cc|c} 1 & 1 & 7 \\ 1 & 1 & 9 \end{array} \right] \left[\begin{array}{l} x + y = 7 \\ x + y = 9 \end{array} \right] \quad (3.78)$$

If we multiply the first row by -1 and add to the second row, we get

$$\left[\begin{array}{cc|c} 1 & 1 & 7 \\ 0 & 0 & 2 \end{array} \right] \left[\begin{array}{l} x + y = 7 \\ 0x + 0y = 2 \end{array} \right] \quad (3.79)$$

Since 0 cannot equal 2 , the last equation cannot be true for any choices of x and y .

Alternatively, it is clear that the two lines are parallel; therefore, they do not intersect.

At this stage, we are going to start using a calculator to row reduce the augmented matrix.

Example 3.20

Solve the following system of equations.

$$2x + 3y - 4z = 7 \quad (3.80)$$

$$3x + 4y - 2z = 9 \quad (3.81)$$

$$5x + 7y - 6z = 20 \quad (3.82)$$

Solution

We enter the following augmented matrix in the calculator.

$$\left[\begin{array}{ccc|c} 2 & 3 & -4 & 7 \\ 3 & 4 & -2 & 9 \\ 5 & 7 & -6 & 20 \end{array} \right] \quad (3.83)$$

Now by pressing the key to obtain the reduced row-echelon form, we get

$$\left[\begin{array}{ccc|c} 1 & 0 & 10 & 0 \\ 0 & 1 & -8 & 0 \\ 0 & 0 & 0 & 1 \end{array} \right] \quad (3.84)$$

The last row indicates that the system is inconsistent; therefore, there is no solution.

Example 3.21

Solve the following system of equations.

$$x + y = 7 \quad (3.85)$$

$$x + y = 7 \quad (3.86)$$

Solution

The problem clearly asks for the intersection of two lines that are the same; that is, the lines coincide. This means the lines intersect at an infinite number of points.

A few intersection points are listed as follows: (3, 4), (5, 2), (-1, 8), (-6, 13) etc. However, when a system has an infinite number of solutions, the solution is often expressed in the parametric form. This can be accomplished by assigning an arbitrary constant, t , to one of the variables, and then solving for the remaining variables. Therefore, if we let $y = t$, then $x = 7 - t$. Or we can say all ordered pairs of the form $(7 - t, t)$ satisfy the given system of equations.

Alternatively, while solving the Gauss-Jordan method, we will get the reduced row-echelon form given below.

$$\left[\begin{array}{cc|c} 1 & 1 & 7 \\ 0 & 0 & 0 \end{array} \right] \quad (3.87)$$

The row of all zeros, can simply be discarded in a manner that it never existed. This leaves us with only one equation but two variables. And whenever there are more variables than the equations, the solution must be expressed in terms of an arbitrary constant, as above. That is, $x = 7 - t$, $y = t$.

Example 3.22

Solve the following system of equations.

$$x + y + z = 2 \tag{3.88}$$

$$2x + y - z = 3 \tag{3.89}$$

$$3x + 2y = 5 \tag{3.90}$$

Solution

The augmented matrix and the reduced row-echelon form are given below.

$$\left[\begin{array}{ccc|c} 1 & 1 & 1 & 2 \\ 2 & 1 & -1 & 3 \\ 3 & 2 & 0 & 5 \end{array} \right] \tag{3.91}$$

$$\left[\begin{array}{ccc|c} 1 & 0 & -2 & 1 \\ 0 & 1 & 3 & 1 \\ 0 & 0 & 0 & 0 \end{array} \right] \tag{3.92}$$

Since the last equation dropped out, we are left with two equations and three variables. This means the system has infinite number of solutions. We express those solutions in the parametric form by letting the last variable z equal the parameter t .

The first equation reads $x - 2z = 1$, therefore, $x = 1 + 2z$.

The second equation reads $y + 3z = 1$, therefore, $y = 1 - 3z$.

And now if we let $z = t$, the solution is expressed as follows:

$$x = 1 + 2t, y = 1 - 3t, z = t. \tag{3.93}$$

The reader should note that particular solutions to the system can be obtained by assigning values to the parameter t . For example, if we let $t = 2$, we have the solution $(5, -5, 2)$.

Example 3.23

Solve the following system of equations.

$$x + 2y - 3z = 5 \tag{3.94}$$

$$2x + 4y - 6z = 10 \tag{3.95}$$

$$3x + 6y - 9z = 15 \tag{3.96}$$

Solution

The reduced row-echelon form is given below.

$$\left[\begin{array}{ccc|c} 1 & 2 & -3 & 5 \\ 0 & 0 & 0 & 0 \\ 0 & 0 & 0 & 0 \end{array} \right] \quad (3.97)$$

This time the last two equations drop out, and we are left with one equation and three variables. Again, there are infinite number of solutions. But this time the answer must be expressed in terms of two arbitrary constants.

If we let $z = t$ and let $y = s$, then the first equation $x + 2y - 3z = 5$ results in $x = 5 - 2s + 3t$.

We rewrite the solution as: $x = 5 - 2s + 3t$, $y = s$, $z = t$.

We summarize our discussion in the following table.

1. If any row of the reduced row-echelon form of the matrix gives a false statement such as $0 = 1$, the system is inconsistent and has no solution.
2. If the reduced row echelon form has fewer equations than the variables and the system is consistent, then the system has an infinite number of solutions. Remember the rows that contain all zeros are dropped.
 - a. If a system has an infinite number of solutions, the solution must be expressed in the parametric form.
 - b. The number of arbitrary parameters equals the number of variables minus the number of equations.

3.5 Inverse Matrices

3.5.1 Section Overview

In this section you will learn to:

1. Find the inverse of a matrix, if it exists.
2. Use inverses to solve linear systems.

In this section, we will learn to find the inverse of a matrix, if it exists. Later, we will use matrix inverses to solve linear systems.

Definition of an Inverse: An $n \times n$ matrix has an inverse if there exists a matrix B such that $AB = BA = I_n$, where I_n is an $n \times n$ identity matrix. The inverse of a matrix A , if it exists, is denoted by the symbol A^{-1} .

Example 3.24

Given matrices A and B below, verify that they are inverses.

$$A = \begin{bmatrix} 4 & 1 \\ 3 & 1 \end{bmatrix} \quad B = \begin{bmatrix} 1 & -1 \\ -3 & 4 \end{bmatrix} \quad (3.98)$$

Solution

The matrices are inverses if the product AB and BA both equal I_2 , the identity matrix of dimension 2×2 .

$$AB = \begin{bmatrix} 4 & 1 \\ 3 & 1 \end{bmatrix} \begin{bmatrix} 1 & -1 \\ -3 & 4 \end{bmatrix} = \begin{bmatrix} 1 & 0 \\ 0 & 1 \end{bmatrix} \quad \text{and} \quad BA = \begin{bmatrix} 1 & -1 \\ -3 & 4 \end{bmatrix} \begin{bmatrix} 4 & 1 \\ 3 & 1 \end{bmatrix} = \begin{bmatrix} 1 & 0 \\ 0 & 1 \end{bmatrix} \quad (3.99)$$

Clearly that is the case; therefore, the matrices A and B are inverses of each other.

Example 3.25

Find the inverse of the following matrix.

$$A = \begin{bmatrix} 3 & 1 \\ 5 & 2 \end{bmatrix} \quad (3.100)$$

Solution

Suppose A has an inverse, and it is

$$B = \begin{bmatrix} a & b \\ c & d \end{bmatrix} \quad (3.101)$$

Then $AB = I$

$$\begin{bmatrix} 3 & 1 \\ 5 & 2 \end{bmatrix} \begin{bmatrix} a & b \\ c & d \end{bmatrix} = \begin{bmatrix} 1 & 0 \\ 0 & 1 \end{bmatrix} \quad (3.102)$$

After multiplying the two matrices on the left side, we get

$$\begin{bmatrix} 3a + c & 3b + 6 \\ 5a + 2c & 5b + 2d \end{bmatrix} = \begin{bmatrix} 1 & 0 \\ 0 & 1 \end{bmatrix} \quad (3.103)$$

Equating the corresponding entries, we get four equations with four unknowns as follows:

$$3a + c = 1 \quad 3b + d = 0 \quad (3.104)$$

$$5a + 2c = 0 \quad 5b + 2d = 1 \quad (3.105)$$

Solving this system, we get

$$a = 2 \quad b = -1 \quad c = -5 \quad d = 3 \quad (3.106)$$

Therefore, the inverse of the matrix A is

$$\begin{bmatrix} 2 & -1 \\ -5 & 3 \end{bmatrix} \quad (3.107)$$

In this problem, finding the inverse of matrix A amounted to solving the system of equations:

$$3a + c = 1 \quad 3b + d = 0 \quad (3.108)$$

$$5a + 2c = 0 \quad 5b + 2d = 1 \quad (3.109)$$

Actually, it can be written as two systems, one with variables a and c , and the other with b and d . The augmented matrices for both are given below.

$$\left[\begin{array}{cc|c} 3 & 1 & 1 \\ 5 & 2 & 0 \end{array} \right] \text{ and } \left[\begin{array}{cc|c} 3 & 1 & 0 \\ 5 & 2 & 1 \end{array} \right] \quad (3.110)$$

As we look at the two augmented matrices, we notice that the coefficient matrix for both the matrices is the same. Which implies the row operations of the Gauss-Jordan method will also be the same. A great deal of work can be saved if the two right hand columns are grouped together to form one augmented matrix as below.

$$\left[\begin{array}{cc|cc} 3 & 1 & 1 & 0 \\ 5 & 2 & 0 & 1 \end{array} \right] \quad (3.111)$$

And solving this system, we get

$$\left[\begin{array}{cc|cc} 1 & 0 & 2 & -1 \\ 0 & 1 & -5 & 3 \end{array} \right] \quad (3.112)$$

The matrix on the right side of the vertical line is the A^{-1} matrix.

What you just witnessed is no coincidence. This is the method that is often employed in finding the inverse of a matrix.

We list the steps, as follows:

3.26: The Method for Finding the Inverse of a Matrix

1. Write the augmented matrix $[A | I_n]$.
2. Write the augmented matrix in step 1 in reduced row echelon form.
3. If the reduced row echelon form in 2 is $\left[\begin{array}{c|c} I_n & B \end{array} \right]$, then B is the inverse of A .
4. If the left side of the row reduced echelon is not an identity matrix, the inverse does not exist.

Example 3.27

Given the matrix A below, find its inverse.

$$A = \left[\begin{array}{ccc} 1 & -1 & 1 \\ 2 & 3 & 0 \\ 0 & -2 & 1 \end{array} \right] \quad (3.113)$$

Solution

We write the augmented matrix as follows.

$$\left[\begin{array}{ccc|ccc} 1 & -1 & 1 & 1 & 0 & 0 \\ 2 & 3 & 0 & 0 & 1 & 0 \\ 0 & -2 & 1 & 0 & 0 & 1 \end{array} \right] \quad (3.114)$$

We reduce this matrix using the Gauss-Jordan method.

Multiplying the first row by -2 and adding it to the second row, we get

$$\left[\begin{array}{ccc|ccc} 1 & -1 & 1 & 1 & 0 & 0 \\ 0 & 5 & -2 & -2 & 1 & 0 \\ 0 & -2 & 1 & 0 & 0 & 1 \end{array} \right] \quad (3.115)$$

If we swap the second and third rows, we get

$$\left[\begin{array}{ccc|ccc} 1 & -1 & 1 & 1 & 0 & 0 \\ 0 & -2 & 1 & 0 & 0 & 1 \\ 0 & 5 & -2 & -2 & 1 & 0 \end{array} \right] \quad (3.116)$$

Divide the second row by -2 . The result is

$$\left[\begin{array}{ccc|ccc} 1 & -1 & 1 & 1 & 0 & 0 \\ 0 & 1 & -1/2 & 0 & 0 & -1/2 \\ 0 & 5 & -2 & -2 & 1 & 0 \end{array} \right] \quad (3.117)$$

Let us do two operations here. 1) Add the second row to first, 2) Add -5 times the second row to the third. And we get

$$\left[\begin{array}{ccc|ccc} 1 & 0 & 1/2 & 1 & 0 & -1/2 \\ 0 & 1 & -1/2 & 0 & 0 & -1/2 \\ 0 & 0 & 1/2 & -2 & 1 & 5/2 \end{array} \right] \quad (3.118)$$

Multiplication of the third row by 2 results in

$$\left[\begin{array}{ccc|ccc} 1 & 0 & 1/2 & 1 & 0 & -1/2 \\ 0 & 1 & -1/2 & 0 & 0 & -1/2 \\ 0 & 0 & 1 & -4 & 2 & 5 \end{array} \right] \quad (3.119)$$

Multiply the third row by $1/2$ and add it to the second. Also, multiply the third row by $-1/2$ and add it to the first. We get

$$\left[\begin{array}{ccc|ccc} 1 & 0 & 0 & 3 & -1 & -3 \\ 0 & 1 & 0 & -2 & 1 & 2 \\ 0 & 0 & 1 & -4 & 2 & 5 \end{array} \right] \quad (3.120)$$

Therefore, the inverse of matrix A is

$$\begin{bmatrix} 3 & -1 & -3 \\ -2 & 1 & 2 \\ -4 & 2 & 5 \end{bmatrix} \quad (3.121)$$

One should verify the result by multiplying the two matrices to see if the product does, indeed, equal the identity matrix.

Now that we know how to find the inverse of a matrix, we will use inverses to solve systems of equations. The method is analogous to solving a simple equation like the one below.

$$\frac{2}{3}x = 4 \quad (3.122)$$

Example 3.28

Solve the following equation .

$$\frac{2}{3}x = 4 \quad (3.123)$$

Solution

To solve the above equation, we multiply both sides of the equation by the multiplicative inverse of $\frac{2}{3}$ which happens to be $\frac{3}{2}$. We get

$$\frac{3}{2} \cdot \frac{2}{3}x = 4 \cdot \frac{3}{2} \quad (3.124)$$

$$x = 6 \quad (3.125)$$

We use the above example as an analogy to show how linear systems of the form $AX = B$ are solved.

To solve a linear system, we first write the system in the matrix equation $AX = B$, where A is the coefficient matrix, X the matrix of variables, and B the matrix of constant terms. We then multiply both sides of this equation by the multiplicative inverse of the matrix A .

Consider the following example.

Example 3.29

Solve the following system

$$3x + y = 3 \quad (3.126)$$

$$5x + 2y = 4 \quad (3.127)$$

Solution

To solve the above equation, first we express the system as

$$AX = B \quad (3.128)$$

where A is the coefficient matrix, and B is the matrix of constant terms. We get

$$\begin{bmatrix} 3 & 1 \\ 5 & 2 \end{bmatrix} \begin{bmatrix} x \\ y \end{bmatrix} = \begin{bmatrix} 3 \\ 4 \end{bmatrix} \quad (3.129)$$

To solve this system, we multiply both sides of the matrix equation $AX = B$ by A^{-1} . Since the matrix A is the same matrix A whose inverse we found in Example 3.25,

$$A^{-1} = \begin{bmatrix} 2 & -1 \\ -5 & 3 \end{bmatrix} \quad (3.130)$$

Multiplying both sides by A^{-1} , we get

$$\begin{bmatrix} 2 & -1 \\ -5 & 3 \end{bmatrix} \begin{bmatrix} 3 & 1 \\ 5 & 2 \end{bmatrix} \begin{bmatrix} x \\ y \end{bmatrix} = \begin{bmatrix} 2 & -1 \\ -5 & 3 \end{bmatrix} \begin{bmatrix} 3 \\ 4 \end{bmatrix} \quad (3.131)$$

$$\begin{bmatrix} 1 & 0 \\ 0 & 1 \end{bmatrix} \begin{bmatrix} x \\ y \end{bmatrix} = \begin{bmatrix} 2 \\ -3 \end{bmatrix} \quad (3.132)$$

$$\begin{bmatrix} x \\ y \end{bmatrix} = \begin{bmatrix} 2 \\ -3 \end{bmatrix} \quad (3.133)$$

Therefore, $x = 2$, and $y = -3$.

Example 3.30

Solve the following system

$$x - y + z = 6 \quad (3.134)$$

$$2x + 3y = 1 \quad (3.135)$$

$$-2y + z = 5 \quad (3.136)$$

Solution

To solve the above equation, we write the system in the matrix form $AX = B$ as follows:

$$\begin{bmatrix} 1 & -1 & 1 \\ 2 & 3 & 0 \\ 0 & -2 & 1 \end{bmatrix} \begin{bmatrix} x \\ y \\ z \end{bmatrix} = \begin{bmatrix} 6 \\ 1 \\ 5 \end{bmatrix}$$

To solve this system, we need inverse of A . From Example 3.27, we have

$$A^{-1} = \begin{bmatrix} 3 & -1 & -3 \\ -2 & 1 & 2 \\ -4 & 2 & 5 \end{bmatrix}$$

We multiply both sides of the matrix equation $AX = B$, by A^{-1} , we get

$$\begin{bmatrix} 3 & -1 & -3 \\ -2 & 1 & 2 \\ -4 & 2 & 5 \end{bmatrix} \begin{bmatrix} 1 & -1 & -3 \\ 2 & 3 & 0 \\ 0 & -2 & 1 \end{bmatrix} \begin{bmatrix} x \\ y \\ z \end{bmatrix} = \begin{bmatrix} 3 & -1 & -3 \\ -2 & 1 & 2 \\ -4 & 2 & 5 \end{bmatrix} \begin{bmatrix} 6 \\ 1 \\ 5 \end{bmatrix}$$

After multiplying the matrices, we get

$$\begin{bmatrix} 1 & 0 & 0 \\ 0 & 1 & 0 \\ 0 & 0 & 1 \end{bmatrix} \begin{bmatrix} x \\ y \\ z \end{bmatrix} = \begin{bmatrix} 2 \\ -1 \\ 3 \end{bmatrix}$$

$$\begin{bmatrix} x \\ y \\ z \end{bmatrix} = \begin{bmatrix} 2 \\ -1 \\ 3 \end{bmatrix}$$

Once again, we remind the reader that not every system of equations can be solved by the matrix inverse method. Although the Gauss-Jordan method works for every situation, the matrix inverse method works only in cases where the inverse of the square matrix exists. In such cases the system has a unique solution.

We summarize our discussion in the following table.

The Method for Finding the Inverse of a Matrix

1. Write the augmented matrix $\left[A \mid I_n \right]$.
2. Write the augmented matrix in step 1 in reduced row echelon form.
3. If the reduced row echelon form in 2 is $\left[I_n \mid B \right]$, then B is the inverse of A .
4. If the left side of the row reduced echelon is not an identity matrix, the inverse does not exist.

The Method for Solving a System of Equations When a Unique Solution Exists

1. Express the system in the matrix equation $AX = B$.
2. To solve the equation $AX = B$, we multiply on both sides by A^{-1} .

3.6 Application of Matrices in Cryptography

In this section, we see a use of matrices in encoding and decoding secret messages. There are many techniques used, but we will use a method that first converts the secret message into a string of numbers by arbitrarily assigning a number to each letter of the message. Next we convert this string of numbers into a new set of numbers by multiplying the string by a square matrix of our choice that has an inverse. This new set of numbers represents the coded message. To decode the message, we take the string of coded numbers and multiply it by the inverse of the matrix to get the original string of numbers. Finally, by associating the numbers with their corresponding letters, we obtain the original message.

In this section, we will use the correspondence where the letters A to Z correspond to the numbers 1 to 26, as shown below, and a space is represented by the number 27, and all punctuation is ignored.

A	B	C	D	E	F	G	H	I	J	K	L	M
1	2	3	4	5	6	7	8	9	10	11	12	13
N	O	P	Q	R	S	T	U	V	W	X	Y	Z
14	15	16	17	18	19	20	21	22	23	24	25	26

Table 3.2

Example 3.31

Use the matrix $A = \begin{bmatrix} 1 & 2 \\ 1 & 3 \end{bmatrix}$ to encode the message: ATTACK NOW!

Solution

We divide the letters of the message into groups of two.

AT TA CK -N OW

We assign the numbers to these letters from the above table, and convert each pair of numbers into 2×1 matrices. In the case where a single letter is left over on the end, a space is added to make it into a pair.

$$\begin{bmatrix} A \\ T \end{bmatrix} = \begin{bmatrix} 1 \\ 20 \end{bmatrix} \begin{bmatrix} T \\ A \end{bmatrix} = \begin{bmatrix} 20 \\ 1 \end{bmatrix} \begin{bmatrix} C \\ K \end{bmatrix} = \begin{bmatrix} 3 \\ 11 \end{bmatrix} \begin{bmatrix} - \\ N \end{bmatrix} = \begin{bmatrix} 27 \\ 14 \end{bmatrix} \begin{bmatrix} O \\ W \end{bmatrix} = \begin{bmatrix} 15 \\ 23 \end{bmatrix} \quad (3.137)$$

So at this stage, our message expressed as 2×1 matrices is as follows.

$$\begin{bmatrix} 1 \\ 20 \end{bmatrix} \begin{bmatrix} 20 \\ 1 \end{bmatrix} \begin{bmatrix} 3 \\ 11 \end{bmatrix} \begin{bmatrix} 27 \\ 14 \end{bmatrix} \begin{bmatrix} 15 \\ 23 \end{bmatrix} \quad (3.138)$$

Now to encode, we multiply, on the left, each matrix of our message by the matrix A. For example, the product of A with our first matrix is

$$\begin{bmatrix} 1 & 2 \\ 1 & 3 \end{bmatrix} \begin{bmatrix} 1 \\ 20 \end{bmatrix} = \begin{bmatrix} 41 \\ 61 \end{bmatrix} \quad (3.139)$$

By multiplying each of the matrices in (I) by the matrix A, we get the desired coded message given below.

$$\begin{bmatrix} 41 \\ 61 \end{bmatrix} \begin{bmatrix} 22 \\ 23 \end{bmatrix} \begin{bmatrix} 25 \\ 36 \end{bmatrix} \begin{bmatrix} 55 \\ 69 \end{bmatrix} \begin{bmatrix} 61 \\ 84 \end{bmatrix} \quad (3.140)$$

Example 3.32

Decode the following message that was encoded using matrix $A = \begin{bmatrix} 1 & 2 \\ 1 & 3 \end{bmatrix}$.

$$\begin{bmatrix} 21 \\ 26 \end{bmatrix} \begin{bmatrix} 37 \\ 53 \end{bmatrix} \begin{bmatrix} 45 \\ 54 \end{bmatrix} \begin{bmatrix} 74 \\ 101 \end{bmatrix} \begin{bmatrix} 53 \\ 69 \end{bmatrix} \quad (3.141)$$

Solution

Since this message was encoded by multiplying by the matrix A in Example 3.31, we decode this message by first multiplying each matrix, on the left, by the inverse of matrix A given below.

$$A^{-1} = \begin{bmatrix} 3 & -2 \\ -1 & 1 \end{bmatrix} \quad (3.142)$$

For example,

$$\begin{bmatrix} 3 & -2 \\ -1 & 1 \end{bmatrix} \begin{bmatrix} 21 \\ 26 \end{bmatrix} = \begin{bmatrix} 11 \\ 5 \end{bmatrix} \quad (3.143)$$

By multiplying each of the matrices in (II) by the matrix A^{-1} , we get the following.

$$\begin{bmatrix} 11 \\ 5 \end{bmatrix} \begin{bmatrix} 5 \\ 16 \end{bmatrix} \begin{bmatrix} 27 \\ 9 \end{bmatrix} \begin{bmatrix} 20 \\ 27 \end{bmatrix} \begin{bmatrix} 21 \\ 16 \end{bmatrix} \quad (3.144)$$

Finally, by associating the numbers with their corresponding letters, we obtain the following.

$$\begin{bmatrix} K \\ E \end{bmatrix} \begin{bmatrix} E \\ P \end{bmatrix} \begin{bmatrix} - \\ I \end{bmatrix} \begin{bmatrix} T \\ - \end{bmatrix} \begin{bmatrix} U \\ P \end{bmatrix} \quad (3.145)$$

And the message reads: KEEP IT UP.

Now suppose we wanted to use a 3×3 matrix to encode a message, then instead of dividing the letters into groups of two, we would divide them into groups of three.

Example 3.33

Using the matrix $B = \begin{bmatrix} 1 & 1 & -1 \\ 1 & 0 & 1 \\ 2 & 1 & 1 \end{bmatrix}$, encode the message: ATTACK NOW!

Solution

We divide the letters of the message into groups of three.

ATT ACK -NO W-

Note that since the single letter "W" was left over on the end, we added two spaces to make it into a triplet.

Now we assign the numbers their corresponding letters from the table, and convert each triplet of numbers into 3×1 matrices. We get

$$\begin{bmatrix} A \\ T \\ T \end{bmatrix} = \begin{bmatrix} 1 \\ 20 \\ 20 \end{bmatrix} \quad \begin{bmatrix} A \\ C \\ K \end{bmatrix} = \begin{bmatrix} 1 \\ 3 \\ 11 \end{bmatrix} \quad \begin{bmatrix} - \\ N \\ O \end{bmatrix} = \begin{bmatrix} 27 \\ 14 \\ 15 \end{bmatrix} \quad \begin{bmatrix} W \\ - \\ - \end{bmatrix} = \begin{bmatrix} 23 \\ 27 \\ 27 \end{bmatrix} \quad (3.146)$$

So far we have,

$$\begin{bmatrix} 1 \\ 20 \\ 20 \end{bmatrix} \begin{bmatrix} 1 \\ 3 \\ 11 \end{bmatrix} \begin{bmatrix} 27 \\ 14 \\ 15 \end{bmatrix} \begin{bmatrix} 23 \\ 27 \\ 27 \end{bmatrix} \quad (3.147)$$

We multiply, on the left, each matrix of our message by the matrix B. For example,

$$\begin{bmatrix} 1 & 1 & -1 \\ 1 & 0 & 1 \\ 2 & 1 & 1 \end{bmatrix} \begin{bmatrix} 1 \\ 20 \\ 20 \end{bmatrix} = \begin{bmatrix} 1 \\ 21 \\ 42 \end{bmatrix} \quad (3.148)$$

By multiplying each of the matrices in (III) by the matrix B, we get the desired coded message as follows:

$$\begin{bmatrix} 1 \\ 21 \\ 42 \end{bmatrix} \begin{bmatrix} -7 \\ 12 \\ 16 \end{bmatrix} \begin{bmatrix} 26 \\ 42 \\ 83 \end{bmatrix} \begin{bmatrix} 23 \\ 50 \\ 100 \end{bmatrix} \quad (3.149)$$

If we need to decode this message, we simply multiply the coded message by B^{-1} , and associate the numbers with the corresponding letters of the alphabet.

Example 3.34

Decode the following message that was encoded using matrix $B = \begin{bmatrix} 1 & 1 & -1 \\ 1 & 0 & 1 \\ 2 & 1 & 1 \end{bmatrix}$.

$$\begin{bmatrix} 11 \\ 20 \\ 43 \end{bmatrix} \begin{bmatrix} 25 \\ 10 \\ 41 \end{bmatrix} \begin{bmatrix} 22 \\ 14 \\ 14 \end{bmatrix} \quad (3.150)$$

Solution

Since this message was encoded by multiplying by the matrix B. We first determine inverse of B.

$$B^{-1} = \begin{bmatrix} 1 & 2 & -1 \\ -1 & -3 & 2 \\ -1 & -1 & 1 \end{bmatrix} \quad (3.151)$$

To decode the message, we multiply each matrix, on the left, by B^{-1} . For example,

$$\begin{bmatrix} 1 & 2 & -1 \\ -1 & -3 & 2 \\ -1 & -1 & 1 \end{bmatrix} \begin{bmatrix} 11 \\ 20 \\ 43 \end{bmatrix} = \begin{bmatrix} 8 \\ 15 \\ 12 \end{bmatrix} \quad (3.152)$$

By multiplying each of the matrices in (**IV**) by the matrix B^{-1} , we get the following.

$$\begin{bmatrix} 8 \\ 15 \\ 12 \end{bmatrix} \begin{bmatrix} 4 \\ 27 \\ 6 \end{bmatrix} \begin{bmatrix} 9 \\ 18 \\ 5 \end{bmatrix} \quad (3.153)$$

Finally, by associating the numbers with their corresponding letters, we obtain the following.

$$\begin{bmatrix} H \\ O \\ L \end{bmatrix} \begin{bmatrix} D \\ \\ F \end{bmatrix} \begin{bmatrix} I \\ R \\ E \end{bmatrix} \quad (3.154)$$

And the message reads: HOLD FIRE.

We summarize.

3.35**TO ENCODE A MESSAGE**

1. Divide the letters of the message into groups of two or three.
2. Convert each group into a string of numbers by assigning a number to each letter of the message. Remember to assign letters to blank spaces.
3. Convert each group of numbers into column matrices.
4. Convert these column matrices into a new set of column matrices by multiplying them with a compatible square matrix of your choice that has an inverse. This new set of numbers or matrices represents the coded message.

TO DECODE A MESSAGE

1. Take the string of coded numbers and multiply it by the inverse of the matrix that was used to encode the message.
2. Associate the numbers with their corresponding letters.

3.7 Applications – Leontief Models

In the 1930's, Wassily Leontief used matrices to model economic systems. His models, often referred to as the input-output models, divide the economy into sectors where each sector produces goods and services not only for itself but also for other sectors. These sectors are dependent on each other and the total input always equals the total output. In 1973, he won the Nobel Prize in Economics for his work in this field. In this section we look at both the closed and the open models that he developed.

The Closed Model

As an example of the closed model, we look at a very simple economy, where there are only three sectors: food, shelter, and clothing.

Example 3.36

We assume that in a village there is a farmer, carpenter, and a tailor, who provide the three essential goods: food, shelter, and clothing. Suppose the farmer himself consumes 40% of the food he produces, and gives 40% to the carpenter, and 20% to the tailor. Thirty percent of the carpenter's production is consumed by himself, 40% by the farmer, and 30% by the carpenter. Fifty percent of the tailor's production is used by himself, 30% by the farmer, and 20% by the tailor. Write the matrix that describes this closed model.

Solution

The table below describes the above information.

	The proportion produced by the farmer	The proportion produced by the carpenter	The proportion produced by the tailor
The proportion used by the farmer	.40	.40	.30
The proportion used by the carpenter	.40	.30	.20
The proportion used by the tailor	.20	.30	.50

Table 3.3

In a matrix form it can be written as follows.

$$A = \begin{bmatrix} .40 & .40 & .30 \\ .40 & .30 & .20 \\ .20 & .30 & .50 \end{bmatrix} \quad (3.155)$$

This matrix is called **the input-output matrix**. It is important that we read the matrix correctly. For example the entry A_{23} , the entry in row 2 and column 3, represents the following.

$A_{23} = 20\%$ of the tailor's production is used by the carpenter.

$A_{33} = 50\%$ of the tailor's production is used by the tailor.

Example 3.37

In Example 3.36 above, how much should each person get for his efforts?

Solution

We choose the following variables.

$$x = \text{Farmer's pay} \quad (3.156)$$

$$y = \text{Carpenter's pay} \quad (3.157)$$

$$z = \text{Tailor's pay} \quad (3.158)$$

As we said earlier, in this model input must equal output. That is, the amount paid by each equals the amount received by each.

Let us say the farmer gets paid x dollars. Let us now look at the farmer's expenses. The farmer uses up 40% of his own production, that is, of the x dollars he gets paid, he pays himself $.40x$ dollars, he pays $.40y$ dollars to the carpenter, and $.30z$ to the tailor. Since the expenses equal the wages, we get the following equation.

$$x = .40x + .40y + .30z \quad (3.159)$$

In the same manner, we get

$$y = .40x + .30y + .20z \quad (3.160)$$

$$z = .20x + .30y + .50z \quad (3.161)$$

The above system can be written as

$$\begin{bmatrix} x \\ y \\ z \end{bmatrix} = \begin{bmatrix} .40 & .40 & .30 \\ .40 & .30 & .20 \\ .20 & .30 & .50 \end{bmatrix} \begin{bmatrix} x \\ y \\ z \end{bmatrix} \quad (3.162)$$

This system is often referred to as

$$X = AX \quad (3.163)$$

Simplification results in

$$.60x - .40y - .30z = 0 \quad (3.164)$$

$$-.40x + .70y - .20z = 0 \quad (3.165)$$

$$-.20x - .30y + .50z = 0 \quad (3.166)$$

Solving for x , y , and z using the Gauss-Jordan method, we get

$$x = \frac{29}{26}t \quad y = \frac{12}{13}t \quad \text{and} \quad z = t \quad (3.167)$$

Since we are only trying to determine the proportions of the pay, we can choose t to be any value. Suppose we let $t = \$2600$, then we get

$$x = \$2900 \quad y = \$2400 \quad \text{and} \quad z = \$2600 \quad (3.168)$$

NOTE: The use of a calculator in solving these problems is strongly recommended. Although we at De Anza College use TI-85 calculators, any calculator that handles matrices will do.

The Open Model

The open model is more realistic, as it deals with the economy where sectors of the economy not only satisfy each others needs, but they also satisfy some outside demands. In this case, the outside demands are put on by the consumer. But the basic assumption is still the same; that is, whatever is produced is consumed.

Let us again look at a very simple scenario. Suppose the economy consists of three people, the farmer F , the carpenter C , and the tailor T . A part of the farmer's production is used by all three, and the rest is used by the consumer. In the same manner, a part of the carpenter's and the tailor's production is used by all three, and rest is used by the consumer.

Let us assume that whatever the farmer produces, 20% is used by him, 15% by the carpenter, 10% by the tailor, and the consumer uses the other 40 billion dollars worth of the food. Ten percent of the carpenter's production is used by him, 25% by the farmer, 5% by the tailor, and 50 billion dollars worth by the consumer. Fifteen percent of the clothing is used by the tailor, 10% by the farmer, 5% by the carpenter, and the remaining 60 billion dollars worth by the consumer. We write the internal consumption in the following table, and express the demand as the matrix D .

	F produces	C produces	T produces
F uses	.20	.25	.10
C uses	.15	.10	.05
T uses	.10	.05	.15

Table 3.4

The consumer demand for each industry in billions of dollars is given below.

$$D = \begin{bmatrix} 40 \\ 50 \\ 60 \end{bmatrix} \quad (3.169)$$

Example 3.38

In Example 3.37, what should be, in billions of dollars, the required output by each industry to meet the demand given by the matrix D ?

Solution

We choose the following variables.

$$x = \text{Farmer's output} \quad (3.170)$$

$$y = \text{Carpenter's output} \quad (3.171)$$

$$z = \text{Tailor's output} \quad (3.172)$$

In the closed model, our equation was $X = AX$, that is, the total input equals the total output. This time our equation is similar with the exception of the demand by the consumer.

So our equation for the open model should be $X = AX + D$, where D represents the demand matrix. We express it as follows:

$$X = AX + D \quad (3.173)$$

$$\begin{bmatrix} x \\ y \\ z \end{bmatrix} = \begin{bmatrix} .20 & .25 & .10 \\ .15 & .10 & .05 \\ .10 & .05 & .15 \end{bmatrix} \begin{bmatrix} x \\ y \\ z \end{bmatrix} + \begin{bmatrix} 40 \\ 50 \\ 60 \end{bmatrix} \quad (3.174)$$

To solve this system, we write it as

$$X = AX + D \quad (3.175)$$

$$(I - A)X = D \quad (3.176)$$

where I is a 3 by 3 identity matrix

$$X = (I - A)^{-1}D \quad (3.177)$$

$$I - A = \begin{bmatrix} .80 & -.25 & -.10 \\ -.15 & .90 & -.05 \\ -.10 & -.05 & .85 \end{bmatrix} \quad (3.178)$$

$$(I - A)^{-1} = \begin{bmatrix} 1.3445 & .3835 & .1807 \\ .2336 & 1.1814 & .097 \\ .1719 & .1146 & 1.2034 \end{bmatrix} \quad (3.179)$$

$$X = \begin{bmatrix} 1.3445 & .3835 & .1807 \\ .2336 & 1.1814 & .097 \\ .1719 & .1146 & 1.2034 \end{bmatrix} \begin{bmatrix} 40 \\ 50 \\ 60 \end{bmatrix} \quad (3.180)$$

$$X = \begin{bmatrix} 83.7999 \\ 74.2341 \\ 84.8138 \end{bmatrix} \quad (3.181)$$

Therefore, the three industries must produce the following amount of goods in billions of dollars.

$$\text{Farmer} = \$83.7999 \quad \text{Carpenter} = \$74.2341 \quad \text{Tailor} = \$84.813 \quad (3.182)$$

We will do one more problem like the one above, except this time we give the amount of internal and external consumption in dollars and ask for the proportion of the amounts consumed by each of the industries. In other words, we ask for the matrix A .

Example 3.39

Suppose an economy consists of three industries F , C , and T . Again, each of the industries produces for internal consumption among themselves, as well as, the external demand by the consumer. The following table gives information about the use of each industry's production in dollars.

	F	C	T	Demand	Total
F	40	50	60	100	250
C	30	40	40	110	220
T	20	30	30	120	200

Table 3.5

The first row says that of the \$250 dollars worth of production by the industry F , \$40 is used by F , \$50 is used by C , \$60 is used by T , and the remainder of \$100 is used by the consumer. The other rows are described in a similar manner.

Find the proportion of the amounts consumed by each of the industries. In other words, find the matrix A .

Once again, the total input equals the total output.

Solution

We are being asked to determine the following:

How much of the production of each of the three industries, F , C , and T is required to produce one unit of F ? In the same way, how much of the production of each of the three industries, F , C , and T is required to produce one unit of C ? And finally, how much of the production of each of the three industries, F , C , and T is required to produce one unit of T ?

Since we are looking for proportions, we need to divide the production of each industry by the total production for each industry.

We analyze as follows:

To produce 250 units of F , we need to use 40 units of F , 50 units of C , and 60 units of T .

Therefore, to produce 1 unit of F , we need to use $40/250$ units of F , $50/250$ units of C , and $60/250$ units of T .

To produce 220 units of C , we need to use 30 units of F , 40 units of C , and 40 units of T .

Therefore, to produce 1 unit of C , we need to use $30/220$ units of F , $40/220$ units of C , and $40/220$ units of T .

To produce 200 units of T , we need to use 20 units of F , 30 units of C , and 30 units of T .

Therefore, to produce 1 unit of T , we need to use $20/200$ units of F , $30/200$ units of C , and $30/200$ units of T .

We obtain the following matrix.

$$A = \begin{bmatrix} 40/250 & 50/220 & 60/200 \\ 30/250 & 40/220 & 40/220 \\ 20/250 & 30/220 & 30/220 \end{bmatrix} \quad (3.183)$$

or

$$A = \begin{bmatrix} .1600 & .2273 & .3000 \\ .1200 & .1818 & .2000 \\ .0800 & .1364 & .1500 \end{bmatrix} \quad (3.184)$$

Clearly

$$AX + D = X \quad (3.185)$$

$$\begin{bmatrix} 40/250 & 50/220 & 60/200 \\ 30/250 & 40/220 & 40/200 \\ 20/250 & 30/220 & 30/200 \end{bmatrix} \begin{bmatrix} 250 \\ 220 \\ 200 \end{bmatrix} + \begin{bmatrix} 100 \\ 110 \\ 120 \end{bmatrix} = \begin{bmatrix} 250 \\ 220 \\ 200 \end{bmatrix} \quad (3.186)$$

We summarize as follows:

3.40: LEONTIEF'S MODELS

THE CLOSED MODEL

1. All consumption is within the industries. There is no external demand.
- 2.

$$\text{Input} = \text{Output} \quad (3.187)$$

3. $X = AX$ or $(I - A)X = 0$

THE OPEN MODEL

1. In addition to internal consumption, there is an outside demand by the consumer.
- 2.

$$\text{Input} = \text{Output} \quad (3.188)$$

3. $X = AX + D$ or $X = (I - A)^{-1}D$

Chapter 4

Matrices: Homework¹

4.1 INTRODUCTION TO MATRICES

A vendor sells hot dogs and corn dogs at three different locations. His total sales (in hundreds) for January and February from the three locations are given in the table below.

	January		February	
	Hot Dogs	Corn Dogs	Hot Dogs	Corn Dogs
Place I	10	8	8	7
Place II	8	6	6	7
Place III	6	4	6	5

Table 4.1

Represent these tables as 3×2 matrices J and F , and answer Exercise 4.1, Exercise 4.2, Exercise 4.3, and Exercise 4.4. problems 1 - 4.

Exercise 4.1

(Solution on p. 91.)

Determine total sales for the two months, that is, find $J + F$.

Exercise 4.2

Find the difference in sales, $J - F$.

Exercise 4.3

(Solution on p. 91.)

If hot dogs sell for \$3 and corn dogs for \$2, find the revenue from the sale of hot dogs and corn dogs. Hint: Let P be a 2×1 matrix. Find $(J + F)P$.

Exercise 4.4

If March sales will be up from February by 10%, 15%, and 20% at Place I, Place II, and Place III, respectively, find the expected number of hot dogs, and corn dogs to be sold in March. Hint: Let R be a 1×3 matrix with entries 1.10, 1.15, and 1.20. Find RF .

Determine the sums and products in the next 5 problems. Given the matrices A , B , C , and D as follows:

$$A = \begin{bmatrix} 3 & 6 & 1 \\ 0 & 1 & 3 \\ 2 & 4 & 1 \end{bmatrix} \quad B = \begin{bmatrix} 1 & -1 & 2 \\ 1 & 4 & 2 \\ 3 & 1 & 1 \end{bmatrix} \quad C = \begin{bmatrix} 1 \\ 2 \\ 3 \end{bmatrix} \quad D = \begin{bmatrix} 2 & 3 & 2 \end{bmatrix}$$

¹This content is available online at <<http://cnx.org/content/m38640/1.2/>>.

Exercise 4.5*(Solution on p. 91.)*

$$3A - 2B \quad (4.1)$$

Exercise 4.6

$$AB + BA \quad (4.2)$$

Exercise 4.7*(Solution on p. 91.)*

$$A^2 \quad (4.3)$$

Exercise 4.8

$$2BC \quad (4.4)$$

Exercise 4.9*(Solution on p. 91.)*

$$2CD + 3AB \quad (4.5)$$

Exercise 4.10

$$A^2B \quad (4.6)$$

Exercise 4.11*(Solution on p. 91.)*

Let $E = \begin{bmatrix} m & n \\ p & q \end{bmatrix}$ and $F = \begin{bmatrix} a & b \\ c & d \end{bmatrix}$, find EF .

Exercise 4.12

Let $G = \begin{bmatrix} 3 & 6 & 1 \\ 0 & 1 & 3 \\ 2 & 4 & 1 \end{bmatrix}$ $H = \begin{bmatrix} x \\ y \\ z \end{bmatrix}$, find GH .

Express the following systems as $AX = B$, where A , X , and B are matrices.

Exercise 4.13*(Solution on p. 91.)*

$$4x - 5y = 6 \quad (4.7)$$

$$5x - 6y = 7 \quad (4.8)$$

Exercise 4.14

$$x - 2y + 2z = 3 \quad (4.9)$$

$$x - 3y + 4z = 7 \quad (4.10)$$

$$x - 2y - 3z = -12 \quad (4.11)$$

Exercise 4.15

(Solution on p. 91.)

$$2x + 3z = 17 \quad (4.12)$$

$$3x - 2y = 10 \quad (4.13)$$

$$5y + 2z = 11 \quad (4.14)$$

Exercise 4.16

$$\begin{aligned} x + 2y + 3z + 2w &= 14 \\ x - 2y - z &= -5 \\ y - 2z + 4w &= 9 \\ x + 3z + 3w &= 15 \end{aligned} \quad (4.15)$$

4.2 SYSTEMS OF LINEAR EQUATIONS

Solve the following by the Gauss-Jordan Method. Show all work.

Exercise 4.17

(Solution on p. 92.)

$$x + 3y = 1 \quad (4.16)$$

$$2x - 5y = 13 \quad (4.17)$$

Exercise 4.18

$$x - y - z = -1 \quad (4.18)$$

$$x - 3y + 2z = 7 \quad (4.19)$$

$$2x - y + z = 3 \quad (4.20)$$

Exercise 4.19

(Solution on p. 92.)

$$x + 2y + 3z = 9 \quad (4.21)$$

$$3x + 4y + z = 5 \quad (4.22)$$

$$2x - y + 2z = 11 \quad (4.23)$$

Exercise 4.20

$$x + 2y = 0 \tag{4.24}$$

$$y + z = 3 \tag{4.25}$$

$$x + 3z = 14 \tag{4.26}$$

Exercise 4.21*(Solution on p. 92.)*

Two apples and four bananas cost \$2.00 and three apples and five bananas cost \$2.70. Find the price of each.

Exercise 4.22

A bowl of corn flakes, a cup of milk, and an egg provide 16 grams of protein. A cup of milk and two eggs provide 21 grams of protein, and two bowls of corn flakes with two cups of milk provide 16 grams of protein. How much protein is provided by one unit of each of these three foods.

Exercise 4.23*(Solution on p. 92.)*

$$x + 2y = 10 \tag{4.27}$$

$$y + z = 5 \tag{4.28}$$

$$z + w = 3 \tag{4.29}$$

$$x + w = 5 \tag{4.30}$$

Exercise 4.24

$$x + w = 6 \tag{4.31}$$

$$2x + y + w = 16 \tag{4.32}$$

$$x - 2z = 0 \tag{4.33}$$

$$z + w = 5 \tag{4.34}$$

4.3 SYSTEMS OF LINEAR EQUATIONS – SPECIAL CASES

Solve the following inconsistent or dependent systems by using the Gauss-Jordan method.

Exercise 4.25

(Solution on p. 92.)

$$2x + 6y = 8 \quad (4.35)$$

$$x + 3y = 4 \quad (4.36)$$

Exercise 4.26

The sum of the digits of a two digit number is 9. The sum of the number and the number obtained by interchanging the digits is 99. Find the number.

Exercise 4.27

(Solution on p. 92.)

$$2x - y = 10 \quad (4.37)$$

$$-4x + 2y = 15 \quad (4.38)$$

Exercise 4.28

$$x + y + z = 6 \quad (4.39)$$

$$3x + 2y + z = 14 \quad (4.40)$$

$$4x + 3y + 2z = 20 \quad (4.41)$$

Exercise 4.29

(Solution on p. 92.)

$$x + 2y - 4z = 1 \quad (4.42)$$

$$2x - 3y + 8z = 9 \quad (4.43)$$

Exercise 4.30

Jessica has a collection of 15 coins consisting of nickels, dimes and quarters. If the total worth of the coins is \$1.80, how many are there of each? Find all three solutions.

Exercise 4.31

(Solution on p. 92.)

The latest reports indicate that there are altogether 20,000 American, French, and Russian troops in Bosnia. The sum of the number of Russian troops and twice the American troops equals 10,000. Furthermore, the Americans have 5,000 more troops than the French. Are these reports consistent?

Exercise 4.32

$$x + y + 2z = 0 \quad (4.44)$$

$$x + 2y + z = 0 \quad (4.45)$$

$$2x + 3y + 3z = 0 \quad (4.46)$$

Exercise 4.33*(Solution on p. 92.)*

Find three solutions to the following system of equations.

$$x + 2y + z = 12 \quad (4.47)$$

$$y = 3 \quad (4.48)$$

Exercise 4.34For what values of k the following system of equations have a). No solution? b). Infinitely many solutions?

$$x + 2y = 5 \quad (4.49)$$

$$2x + 4y = k \quad (4.50)$$

Exercise 4.35*(Solution on p. 92.)*

$$x + 3y - z = 5 \quad (4.51)$$

Exercise 4.36

Why is it not possible for a linear system to have exactly two solutions? Explain geometrically.

4.4 INVERSE MATRICES

In the next two problems, verify that the given matrices are inverses of each other.

Exercise 4.37

$$\begin{bmatrix} 7 & 3 \\ 2 & 1 \end{bmatrix} \begin{bmatrix} 1 & -3 \\ -2 & 7 \end{bmatrix} \quad (4.52)$$

Exercise 4.38

$$\begin{bmatrix} 1 & -1 & 0 \\ 1 & 0 & -1 \\ 2 & 3 & -4 \end{bmatrix} \begin{bmatrix} 3 & -4 & 1 \\ 2 & -4 & 1 \\ 3 & -5 & 1 \end{bmatrix} \quad (4.53)$$

In the following problems, find the inverse of each matrix by the row-reduction method.

Exercise 4.39*(Solution on p. 92.)*

$$\begin{bmatrix} 3 & -5 \\ -1 & 2 \end{bmatrix} \quad (4.54)$$

Exercise 4.40

$$\begin{bmatrix} 1 & 0 & 2 \\ 0 & 1 & 4 \\ 0 & 0 & 1 \end{bmatrix} \quad (4.55)$$

Exercise 4.41*(Solution on p. 92.)*

$$\begin{bmatrix} 1 & 1 & -1 \\ 1 & 0 & 1 \\ 2 & 1 & 1 \end{bmatrix} \quad (4.56)$$

Exercise 4.42

$$\begin{bmatrix} 1 & 1 & 1 \\ 3 & 1 & 0 \\ 1 & 1 & 2 \end{bmatrix} \quad (4.57)$$

In the following problems, first express the system as $AX = B$, and then solve using matrix inverses found in the preceding four problems.

Exercise 4.43*(Solution on p. 92.)*

$$3x - 5y = 2 \quad (4.58)$$

$$-x + 2y = 0 \quad (4.59)$$

Exercise 4.44

$$\begin{aligned} x + \quad \quad \quad 2z &= 8 \\ \quad y + 4z &= 8 \\ \quad \quad \quad z &= 3 \end{aligned} \quad (4.60)$$

Exercise 4.45*(Solution on p. 92.)*

$$\begin{aligned} x + y - z &= 2 \\ x + \quad \quad z &= 7 \\ 2x + y + z &= 13 \end{aligned} \quad (4.61)$$

Exercise 4.46

$$\begin{aligned} x + y + z &= 2 \\ 3x + y &= 7 \\ x + y + 2z &= 3 \end{aligned} \quad (4.62)$$

Exercise 4.47*(Solution on p. 92.)*

Why is it necessary that a matrix be a square matrix for its inverse to exist? Explain by relating the matrix to a system of equations.

Exercise 4.48

Suppose we are solving a system $AX = B$ by the matrix inverse method, but discover A has no inverse. How else can we solve this system? What can be said about the solutions of this system?

4.5 APPLICATION OF MATRICES IN CRYPTOGRAPHY

In the following problems, the letters A to Z correspond to the numbers 1 to 26, as shown below, and a space is represented by the number 27.

A	B	C	D	E	F	G	H	I	J	K	L	M
1	2	3	4	5	6	7	8	9	10	11	12	13
N	O	P	Q	R	S	T	U	V	W	X	Y	Z
14	15	16	17	18	19	20	21	22	23	24	25	26

Table 4.2

In the next two problems, use the matrix A , given below, to encode the given messages.

$$A = \begin{bmatrix} 3 & 2 \\ 1 & 1 \end{bmatrix}$$

In the two problems following, decode the messages that were encoded using matrix A .

Make sure to consider the spaces between words, but ignore all punctuation. Add a final space if necessary.

Exercise 4.49*(Solution on p. 92.)*

Encode the message: WATCH OUT!

Exercise 4.50

Encode the message: HELP IS ON THE WAY.

Exercise 4.51*(Solution on p. 92.)*

Decode the following message:

64 23 102 41 82 32 97 35 71 28 69 32

Exercise 4.52

Decode the following message:

105 40 117 48 39 19 69 32 72 27 37 15 114 47

In the next two problems, use the matrix B , given below, to encode the given messages.

$$B = \begin{bmatrix} 1 & 0 & 0 \\ 2 & 1 & 2 \\ 1 & 0 & -1 \end{bmatrix}$$

In the two problems following, decode the messages that were encoded using matrix B .

Make sure to consider the spaces between words, but ignore all punctuation. Add a final space(s) if necessary.

Exercise 4.53*(Solution on p. 92.)*

Encode the message using matrix B :

LUCK IS ON YOUR SIDE.

Exercise 4.54

Encode the message using matrix B :
MAY THE FORCE BE WITH YOU.

Exercise 4.55

Decode the following message that was encoded using matrix B :
8 23 7 4 47 -2 15 102 -12 20 58 15 27 80 18 12 74 -7

*(Solution on p. 93.)***Exercise 4.56**

Decode the following message that was encoded using matrix B :
12 69 -3 11 53 9 5 46 -10 18 95 -9 25 107 4 27 76 22 1 72 -26

4.6 APPLICATIONS – LEONTIEF MODELS**Exercise 4.57**

Solve the following homogeneous system.

(Solution on p. 93.)

$$x + y + z = 0 \quad (4.63)$$

$$3x + 2y + z = 0 \quad (4.64)$$

$$4x + 3y + 2z = 0 \quad (4.65)$$

Exercise 4.58

Solve the following homogeneous system.

$$x - y - z = 0 \quad (4.66)$$

$$x - 3y + 2z = 0 \quad (4.67)$$

$$2x - 4y + z = 0 \quad (4.68)$$

Exercise 4.59*(Solution on p. 93.)*

Chris and Ed decide to help each other by doing repairs on each others houses. Chris is a carpenter, and Ed is an electrician. Chris does carpentry work on his house as well as on Ed's house. Similarly, Ed does electrical repairs on his house and on Chris' house. When they are all finished they realize that Chris spent 60% of his time on his own house, and 40% of his time on Ed's house. On the other hand Ed spent half of his time on his house and half on Chris's house. If they originally agreed that each should get about a \$1000 for their work, how much money should each get for their work?

Exercise 4.60

Chris, Ed, and Paul decide to help each other by doing repairs on each others houses. Chris is a carpenter, Ed is an electrician, and Paul is a plumber. Each does work on his own house as well as on the others houses. When they are all finished they realize that Chris spent 30% of his time on his own house, 40% of his time on Ed's house, and 30% on Paul's house. Ed spent half of his time on his own house, 30% on Chris' house, and remaining on Paul's house. Paul spent 40% of the time on his own house, 40% on Chris' house, and 20% on Ed's house. If they originally agreed that each should get about a \$1000 for their work, how much money should each get for their work?

Exercise 4.61*(Solution on p. 93.)*

Given the internal consumption matrix A , and the external demand matrix D as follows.

$$A = \begin{bmatrix} .30 & .20 & .10 \\ .20 & .10 & .30 \\ .10 & .20 & .30 \end{bmatrix} \quad D = \begin{bmatrix} 100 \\ 150 \\ 200 \end{bmatrix} \quad (4.69)$$

Solve the system using the open model: $X = AX + D$ or $X = (I - A)^{-1}D$

Exercise 4.62

Given the internal consumption matrix A , and the external demand matrix D as follows.

$$A = \begin{bmatrix} .05 & .10 & .10 \\ .10 & .15 & .05 \\ .05 & .20 & .20 \end{bmatrix} \quad D = \begin{bmatrix} 50 \\ 100 \\ 80 \end{bmatrix} \quad (4.70)$$

Solve the system using the open model: $X = AX + D$ or $X = (I - A)^{-1}D$

Exercise 4.63*(Solution on p. 93.)*

An economy has two industries, farming and building. For every \$1 of food produced, the farmer uses \$.20 and the builder uses \$.15. For every \$1 worth of building, the builder uses \$.25 and the farmer uses \$.20. If the external demand for food is \$100,000, and for building \$200,000, what should be the total production for each industry in dollars?

Exercise 4.64

An economy has three industries, farming, building, and clothing. For every \$1 of food produced, the farmer uses \$.20, the builder uses \$.15, and the tailor \$.05. For every \$1 worth of building, the builder uses \$.25, the farmer uses \$.20, and the tailor \$.10. For every \$1 worth of clothing, the tailor uses \$.10, the builder uses \$.20, the farmer uses \$.15. If the external demand for food is \$100 million, for building \$200 million, and for clothing \$300 million, what should be the total production for each in dollars?

Exercise 4.65*(Solution on p. 93.)*

Suppose an economy consists of three industries F , C , and T . The following table gives information about the internal use of each industry's production and external demand in dollars.

	F	C	T	Demand	Total
F	30	10	20	40	100
C	20	30	20	50	120
T	10	10	30	60	110

Table 4.3

Find the proportion of the amounts consumed by each of the industries; that is, find the matrix A .

Exercise 4.66

If in the preceding problem, the consumer demand for F , C , and T becomes 60, 80, and 100, respectively, find the total output and the internal use by each industry to meet that demand.

4.7 CHAPTER REVIEW

Exercise 4.67

(Solution on p. 93.)

To reinforce her diet, Mrs. Tam bought a bottle containing 30 tablets of Supplement A and a bottle containing 50 tablets of Supplement B . Each tablet of supplement A contains 1000 mg of calcium, 400 mg of magnesium, and 15 mg of zinc, and each tablet of supplement B contains 800 mg of calcium, 500 mg of magnesium, and 20 mg of zinc.

- Represent the amount of calcium, magnesium and zinc in each tablet as a 2×3 matrix.
- Represent the number of tablets in each bottle as a row matrix.
- Use matrix multiplication to determine the total amount of calcium, magnesium, and zinc in both bottles.

Exercise 4.68

(Solution on p. 93.)

Let matrix $A = \begin{bmatrix} 1 & -1 & 3 \\ 3 & -2 & 1 \end{bmatrix}$ and $B = \begin{bmatrix} 3 & 3 & -1 \\ 1 & 4 & -3 \end{bmatrix}$. Find the following.

- $\frac{1}{2}(A + B)$
- $3A - 2B$

Exercise 4.69

(Solution on p. 93.)

Let matrix $C = \begin{bmatrix} 1 & 1 & -1 \\ 2 & 1 & 1 \\ 1 & 0 & 1 \end{bmatrix}$ and $D = \begin{bmatrix} 2 & -3 & -1 \\ 3 & -1 & -2 \\ 3 & -3 & -2 \end{bmatrix}$. Find the following.

- $2(C - D)$
- $C - 3D$

Exercise 4.70

(Solution on p. 94.)

Let matrix $E = \begin{bmatrix} 1 & -1 \\ 2 & 3 \\ 1 & 2 \end{bmatrix}$ and $F = \begin{bmatrix} 2 & 1 & -1 \\ 1 & 2 & -3 \end{bmatrix}$. Find the following.

- $2EF$
- $3FE$

Exercise 4.71

(Solution on p. 94.)

Let matrix $G = \begin{bmatrix} 1 & -1 & 3 \\ 3 & 2 & 1 \end{bmatrix}$ and $H = \begin{bmatrix} a & b \\ c & d \\ e & f \end{bmatrix}$. Find the following.

- $2GH$
- HG

Exercise 4.72

(Solution on p. 94.)

Solve the following systems using the Gauss-Jordan Method.

$$\begin{array}{l}
 x + 3y - 2z = 7 \\
 \text{a. } 2x + 7y - 5z = 1 \\
 x + 5y - 3z = 1 \\
 2x - 4y + 4z = 2 \\
 \text{b. } 2x + y + 9z = 1 \\
 3x - 2y + 2z = 7
 \end{array}$$

Exercise 4.73*(Solution on p. 94.)*

An apple, a banana and three oranges or two apples, two bananas, and an orange, or four bananas and two oranges cost \$2. Find the price of each.

Exercise 4.74*(Solution on p. 94.)*

Solve the following systems. If a system has an infinite number of solutions, first express the solution in parametric form, and then determine one particular solution.

$$\begin{array}{l}
 x + y + z = 6 \\
 \text{a. } 2x - 3y + 2z = 1 \\
 3x - 2y + 3z = 1 \\
 x + y + 3z = 4 \\
 \text{b. } x + z = 1 \\
 2x - y = 2
 \end{array}$$

Exercise 4.75*(Solution on p. 94.)*

Elise has a collection of 12 coins consisting of nickels, dimes and quarters. If the total worth of the coins is \$1.80, how many are there of each? Find all possible solutions.

Exercise 4.76*(Solution on p. 94.)*

Solve the following systems. If a system has an infinite number of solutions, first express the solution in parametric form, and then find a particular solution.

$$\begin{array}{l}
 x + 2y = 4 \\
 \text{a. } 2x + 4y = 8 \\
 3x + 6y - 3z = 3 \\
 \text{b. } x - 2y + 2z = 1 \\
 2x - 3y + 5z = 4
 \end{array}$$

Exercise 4.77*(Solution on p. 94.)*

Solve the following systems. If a system has an infinite number of solutions, first express the solution in parametric form, and then provide one particular solution.

$$\begin{array}{l}
 2x + y - 2z = 0 \\
 \text{a. } 2x + 2y - 3z = 0 \\
 6x + 4y - 7z = 0 \\
 3x + 4y - 3z = 5 \\
 \text{b. } 2x + 3y - z = 4 \\
 x + 2y + z = 1
 \end{array}$$

Exercise 4.78*(Solution on p. 94.)*

Find the inverse of the following matrices.

$$\text{a. } \begin{bmatrix} 2 & 3 \\ 3 & 5 \end{bmatrix}$$

$$\text{b. } \begin{bmatrix} 1 & 1 & 1 \\ 1 & 2 & 1 \\ 2 & 3 & 1 \end{bmatrix}$$

Exercise 4.79*(Solution on p. 95.)*

Solve the following systems using the matrix inverse method.

$$\begin{array}{l} 2x + 3y + z = 1 \\ \text{a. } x + 2y + z = 9 \\ x + y + z = 5 \\ x + 2y - 3z + w = 7 \\ \text{b. } x \quad \quad - z \quad \quad = 4 \\ x - 2y + z \quad \quad = 0 \\ y - 2z + w = - \end{array}$$

Exercise 4.80*(Solution on p. 95.)*Use matrix A , given below, to encode the following messages. The space between the letters is represented by the number 27, and all punctuation is ignored.

$$A = \begin{bmatrix} 1 & 2 & 0 \\ 1 & 2 & 1 \\ 0 & 1 & 0 \end{bmatrix} \quad (4.71)$$

- a. TAKE IT AND RUN.
- b. GET OUT QUICK.

Exercise 4.81*(Solution on p. 95.)*Decode the following messages that were encoded using matrix A in the above problem.

- a. 44, 71, 15, 18, 27, 1, 68, 82, 27, 69, 76, 27, 19, 33, 9
- b. 37, 64, 15, 36, 54, 15, 67, 75, 20, 59, 66, 27, 39, 43, 12

Exercise 4.82*(Solution on p. 95.)*

Chris, Bob, and Matt decide to help each other study during the final exams. Chris's favorite subject is chemistry, Bob loves biology, and Matt knows his math. Each studies his own subject as well as helps the others learn their subjects. After the finals, they realize that Chris spent 40% of his time studying his own subject chemistry, 30% of his time helping Bob learn chemistry, and 30% of the time helping Matt learn chemistry. Bob spent 30% of his time studying his own subject biology, 30% of his time helping Chris learn biology, and 40% of the time helping Matt learn biology. Matt spent 20% of his time studying his own subject math, 40% of his time helping Chris learn

math, and 40% of the time helping Bob learn math. If they originally agreed that each should work about 33 hours, how long did each work?

Exercise 4.83*(Solution on p. 95.)*

As in the previous problem, Chris, Bob, and Matt decide to not only help each other study during the final exams, but also tutor others to make a little money. Chris spends 30% of his time studying chemistry, 15% of his time helping Bob with chemistry, and 25% helping Matt with chemistry. Bob spends 25% of his time studying biology, 15% helping Chris with biology, and 30% helping Matt. Similarly, Matt spends 20% of his time on his own math, 20% helping Chris, and 20% helping Bob. If they spend respectively, 12, 12, and 10 hours tutoring others, how many total hours are they going to end up working?

Solutions to Exercises in Chapter 4

Solutions to Matrices: Homework

Solution to Exercise 4.1 (p. 77)

$$\begin{bmatrix} 18 & 15 \\ 14 & 13 \\ 12 & 9 \end{bmatrix} \quad (4.72)$$

Solution to Exercise 4.3 (p. 77)

$$\begin{bmatrix} 84 \\ 68 \\ 54 \end{bmatrix} \quad (4.73)$$

Solution to Exercise 4.5 (p. 77)

$$\begin{bmatrix} 7 & 20 & -1 \\ -2 & -5 & 5 \\ 0 & 10 & 1 \end{bmatrix} \quad (4.74)$$

Solution to Exercise 4.7 (p. 78)

$$\begin{bmatrix} 11 & 28 & 22 \\ 6 & 13 & 6 \\ 8 & 20 & 15 \end{bmatrix} \quad (4.75)$$

Solution to Exercise 4.9 (p. 78)

$$\begin{bmatrix} 40 & 72 & 61 \\ 38 & 33 & 23 \\ 39 & 63 & 51 \end{bmatrix} \quad (4.76)$$

Solution to Exercise 4.11 (p. 78)

$$\begin{bmatrix} ma + nc & mb + nd \\ pa + qc & pb + qd \end{bmatrix} \quad (4.77)$$

Solution to Exercise 4.13 (p. 78)

$$\begin{bmatrix} 4 & -5 \\ 5 & -6 \end{bmatrix} \begin{bmatrix} x \\ y \end{bmatrix} = \begin{bmatrix} 6 \\ 7 \end{bmatrix} \quad (4.78)$$

Solution to Exercise 4.15 (p. 79)

$$\begin{bmatrix} 2 & 0 & 3 \\ 3 & -2 & 0 \\ 0 & 5 & 2 \end{bmatrix} \begin{bmatrix} x \\ y \\ z \end{bmatrix} = \begin{bmatrix} 17 \\ 10 \\ 11 \end{bmatrix} \quad (4.79)$$

Solution to Exercise 4.17 (p. 79)

(4,-1)

Solution to Exercise 4.19 (p. 79)

(2, -1, 3)

Solution to Exercise 4.21 (p. 80)

(0.4, 0.3)

Solution to Exercise 4.23 (p. 80)

(4, 3, 2, 1)

Solution to Exercise 4.25 (p. 81)

$$(4 - 3t, t) \tag{4.80}$$

Solution to Exercise 4.27 (p. 81)

Inconsistent system, no solution

Solution to Exercise 4.29 (p. 81)

$(3 - 4/7t, -1 + 16/7t, t)$

Solution to Exercise 4.31 (p. 81)

No, they are not consistent.

Solution to Exercise 4.33 (p. 82)

(5, 3, 1), (4, 3, 2) (3, 3, 3)

Solution to Exercise 4.35 (p. 82)

$(5 - 3s + t, s, t)$

Solution to Exercise 4.39 (p. 82)

$$\begin{bmatrix} 2 & 5 \\ 1 & 3 \end{bmatrix} \tag{4.81}$$

Solution to Exercise 4.41 (p. 83)

$$\begin{bmatrix} 1 & 2 & - - 1 \\ - - 1 & - - 3 & 2 \\ - - 1 & - - 1 & 1 \end{bmatrix} \tag{4.82}$$

Solution to Exercise 4.43 (p. 83)

(4, 2)

Solution to Exercise 4.45 (p. 83)

(3, 3, 4)

Solution to Exercise 4.47 (p. 84)

If a matrix M has an inverse, then the system of linear equations that has M as its coefficient matrix has a unique solution. If a system of linear equations has a unique solution, then the number of equations must be the same as the number of variables. Therefore, the matrix that represents its coefficient matrix must be a square matrix.

Solution to Exercise 4.49 (p. 84)

$$\begin{bmatrix} 71 \\ 24 \end{bmatrix} \begin{bmatrix} 66 \\ 23 \end{bmatrix} \begin{bmatrix} 78 \\ 35 \end{bmatrix} \begin{bmatrix} 87 \\ 36 \end{bmatrix} \begin{bmatrix} 114 \\ 47 \end{bmatrix} \tag{4.83}$$

Solution to Exercise 4.51 (p. 84)

RETURN HOME

Solution to Exercise 4.53 (p. 84)

$$\begin{bmatrix} 12 \\ 51 \\ 9 \end{bmatrix} \begin{bmatrix} 11 \\ 67 \\ 2 \end{bmatrix} \begin{bmatrix} 19 \\ 95 \\ 14 \end{bmatrix} \begin{bmatrix} 14 \\ 105 \\ -11 \end{bmatrix} \begin{bmatrix} 15 \\ 87 \\ -3 \end{bmatrix} \begin{bmatrix} 27 \\ 91 \\ 18 \end{bmatrix} \begin{bmatrix} 4 \\ 67 \\ -23 \end{bmatrix} \quad (4.84)$$

Solution to Exercise 4.55 (p. 85)

HEAD FOR THE HILLS

Solution to Exercise 4.57 (p. 85) $(t, -2t, t)$ **Solution to Exercise 4.59 (p. 85)**

Chris = \$1250, Ed = \$1,000

Solution to Exercise 4.61 (p. 86)

$$\begin{bmatrix} 315.34 \\ 383.52 \\ 440.34 \end{bmatrix} \quad (4.85)$$

Solution to Exercise 4.63 (p. 86)

$$\text{Farming} = \$201,754.38, \text{Building} = \$307,017.54 \quad (4.86)$$

Solution to Exercise 4.65 (p. 86)

$$\begin{bmatrix} 30/100 & 10/120 & 20/110 \\ 20/100 & 30/120 & 20/110 \\ 10/100 & 10/120 & 30/110 \end{bmatrix} \quad (4.87)$$

Solution to Exercise 4.67 (p. 87)

a. $\begin{bmatrix} 1000 & 400 & 15 \\ 800 & 500 & 20 \end{bmatrix}$

b. $\begin{bmatrix} 30 & 50 \end{bmatrix}$

Solution to Exercise 4.68 (p. 87)

a. $\begin{bmatrix} 2 & 1 & 1 \\ 2 & 1 & -1 \end{bmatrix}$

b.

$$\begin{bmatrix} -3 & -9 & 11 \\ 7 & -14 & 9 \end{bmatrix} \quad (4.88)$$

Solution to Exercise 4.69 (p. 87)

a. $\begin{bmatrix} -2 & 8 & 0 \\ -2 & 4 & 6 \\ -4 & 6 & 6 \end{bmatrix}$

b.

$$\begin{bmatrix} -5 & 10 & 2 \\ -7 & 4 & 7 \\ -8 & 9 & 7 \end{bmatrix} \quad (4.89)$$

Solution to Exercise 4.70 (p. 87)

$$\text{a. } \begin{bmatrix} 2 & -2 & 4 \\ 14 & 16 & -22 \\ 8 & 10 & -14 \end{bmatrix}$$

b.

$$\begin{bmatrix} 9 & -3 \\ 6 & -3 \end{bmatrix} \quad (4.90)$$

Solution to Exercise 4.71 (p. 87)

$$\text{a. } \begin{bmatrix} 2a - 2c + 6e & 2b - 2d + 6f \\ 6a + 4c + 2e & 6b + 4d + 2f \end{bmatrix}$$

b.

$$\begin{bmatrix} a + 3b & -a + 2b & 3a + b \\ c + 3d & -c + 2d & 3c + d \\ e + 3f & -e + 2f & 3e + f \end{bmatrix} \quad (4.91)$$

Solution to Exercise 4.72 (p. 87)

a. (2, 1, -1)

b. (3, 2, 1)

Solution to Exercise 4.73 (p. 88)

Apple = \$.50; banana = \$.30; orange = \$.40

Solution to Exercise 4.74 (p. 88)a. $x = 6 - t$, $y = 0$, $z = t$; (5, 0, 1)

b. no solution

Solution to Exercise 4.75 (p. 88) $n = 3t - 12$, $d = -4t + 24$, $q = t$; $n = 3$, $d = 4$, $q = 5$ **Solution to Exercise 4.76 (p. 88)**a. $x = 4 - 2t$, $y = t$, $z = 3$; (4, 0, 3)b. $x = 5 - 4t$, $y = 2 - t$, $z = t$; (1, 1, 1)**Solution to Exercise 4.77 (p. 88)**a. $x = .5t$, $y = t$, $z = 2t$; (1, 2, 2)

b. no solution

Solution to Exercise 4.78 (p. 89)

a.

$$\begin{bmatrix} 5 & -3 \\ -3 & 2 \end{bmatrix} \quad (4.92)$$

b.

$$\begin{bmatrix} 1 & -2 & 1 \\ -1 & 1 & 0 \\ 1 & 1 & -1 \end{bmatrix} \quad (4.93)$$

Solution to Exercise 4.79 (p. 89)

- a. (-1, 4, 2)
b. (6, 4, 2, -1)

Solution to Exercise 4.80 (p. 89)

a.

$$\begin{bmatrix} 22 \\ 33 \\ 1 \end{bmatrix} \begin{bmatrix} 59 \\ 68 \\ 27 \end{bmatrix} \begin{bmatrix} 74 \\ 75 \\ 27 \end{bmatrix} \begin{bmatrix} 22 \\ 49 \\ 4 \end{bmatrix} \begin{bmatrix} 60 \\ 74 \\ 21 \end{bmatrix} \quad (4.94)$$

b.

$$\begin{bmatrix} 17 \\ 37 \\ 5 \end{bmatrix} \begin{bmatrix} 57 \\ 78 \\ 15 \end{bmatrix} \begin{bmatrix} 74 \\ 91 \\ 27 \end{bmatrix} \begin{bmatrix} 39 \\ 42 \\ 9 \end{bmatrix} \begin{bmatrix} 65 \\ 92 \\ 27 \end{bmatrix} \quad (4.95)$$

Solution to Exercise 4.81 (p. 89)

- a. NO PAIN NO GAIN
b. GO FOR THE GOLD

Solution to Exercise 4.82 (p. 89)

$$x = 40/33t, y = 36/33t, z = t; \text{ Chris} = 40\text{hrs}, \text{ Bob} = 36\text{hrs}, \text{ Matt} = 33\text{hrs} \quad (4.96)$$

Solution to Exercise 4.83 (p. 90)

$$\text{Chris} = 34.1\text{hrs}, \text{ Bob} = 32.2\text{hrs}, \text{ Matt} = 35.2\text{hrs} \quad (4.97)$$

Chapter 5

Linear Programming: A Geometric Approach¹

5.1 Chapter Overview

In this chapter, you will learn to:

1. Solve linear programming problems that maximize the objective function.
2. Solve linear programming problems that minimize the objective function.

5.2 Maximization Applications

Application problems in business, economics, and social and life sciences often ask us to make decisions on the basis of certain conditions. These conditions or constraints often take the form of inequalities. In this section, we will look at such problems.

A typical **linear programming** problem consists of finding an extreme value of a linear function subject to certain constraints. We are either trying to maximize or minimize our function. That is why these linear programming problems are classified as **maximization** or **minimization problems**, or just **optimization problems**. The function we are trying to optimize is called an **objective function**, and the conditions that must be satisfied are called **constraints**. In this chapter, we will do problems that involve only two variables, and therefore, can be solved by graphing. We begin by solving a maximization problem.

Example 5.1

Niki holds two part-time jobs, Job I and Job II. She never wants to work more than a total of 12 hours a week. She has determined that for every hour she works at Job I, she needs 2 hours of preparation time, and for every hour she works at Job II, she needs one hour of preparation time, and she cannot spend more than 16 hours for preparation. If she makes \$40 an hour at Job I, and \$30 an hour at Job II, how many hours should she work per week at each job to maximize her income?

Solution

We start by choosing our variables.

Let x = The number of hours per week Niki will work at Job I.

and y = The number of hours per week Niki will work at Job II.

¹This content is available online at <<http://cnx.org/content/m18903/1.2/>>.

Now we write the objective function. Since Niki gets paid \$40 an hour at Job I, and \$30 an hour at Job II, her total income I is given by the following equation.

$$I = 40x + 30y \quad (5.1)$$

Our next task is to find the constraints. The second sentence in the problem states, "She never wants to work more than a total of 12 hours a week." This translates into the following constraint:

$$x + y \leq 12 \quad (5.2)$$

The third sentence states, "For every hour she works at Job I, she needs 2 hours of preparation time, and for every hour she works at Job II, she needs one hour of preparation time, and she cannot spend more than 16 hours for preparation." The translation follows.

$$2x + y \leq 16 \quad (5.3)$$

The fact that x and y can never be negative is represented by the following two constraints:

$$x \geq 0, \text{ and } y \geq 0.$$

Well, good news! We have formulated the problem. We restate it as

$$\text{Maximize } I = 40x + 30y$$

$$\text{Subject to: } x + y \leq 12$$

$$2x + y \leq 16 \quad (5.4)$$

$$x \geq 0; y \geq 0 \quad (5.5)$$

In order to solve the problem, we graph the constraints as follows.

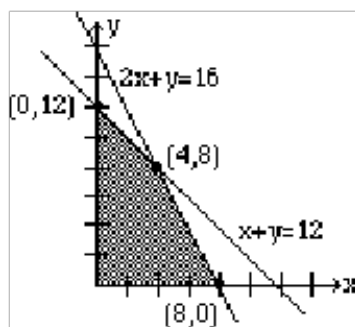

Figure 5.1

Observe that we have shaded the region where all conditions are satisfied. This region is called the **feasibility region** or the feasibility polygon.

The **Fundamental Theorem of Linear Programming** states that the maximum (or minimum) value of the objective function always takes place at the vertices of the feasibility region.

Therefore, we will identify all the vertices of the feasibility region. We call these points critical points. They are listed as $(0, 0)$, $(0, 12)$, $(4, 8)$, $(8, 0)$. To maximize Niki's income, we will substitute these points in the objective function to see which point gives us the highest income per week. We list the results below.

Critical Points	Income
$(0,0)$	$40(0) + 30(0) = \$0$
$(0,12)$	$40(0) + 30(12) = \$360$
$(4,8)$	$40(4) + 30(8) = \$400$
$(8,0)$	$40(8) + 30(0) = \$320$

Table 5.1

Clearly, the point $(4, 8)$ gives the most profit: \$400.

Therefore, we conclude that Niki should work 4 hours at Job I, and 8 hours at Job II.

Example 5.2

A factory manufactures two types of gadgets, regular and premium. Each gadget requires the use of two operations, assembly and finishing, and there are at most 12 hours available for each operation. A regular gadget requires 1 hour of assembly and 2 hours of finishing, while a premium gadget needs 2 hours of assembly and 1 hour of finishing. Due to other restrictions, the company can make at most 7 gadgets a day. If a profit of \$20 is realized for each regular gadget and \$30 for a premium gadget, how many of each should be manufactured to maximize profit?

Solution

We choose our variables.

Let x = The number of regular gadgets manufactured each day.

and y = The number of premium gadgets manufactured each day.

The objective function is

$$P = 20x + 30y \quad (5.6)$$

We now write the constraints. The fourth sentence states that the company can make at most 7 gadgets a day. This translates as

$$x + y \leq 7 \quad (5.7)$$

Since the regular gadget requires one hour of assembly and the premium gadget requires two hours of assembly, and there are at most 12 hours available for this operation, we get

$$x + 2y \leq 12 \quad (5.8)$$

Similarly, the regular gadget requires two hours of finishing and the premium gadget one hour. Again, there are at most 12 hours available for finishing. This gives us the following constraint.

$$2x + y \leq 12 \quad (5.9)$$

The fact that x and y can never be negative is represented by the following two constraints:

$$x \geq 0, \text{ and } y \geq 0.$$

We have formulated the problem as follows:

$$\text{Maximize } P = 20x + 30y$$

$$\text{Subject to: } x + y \leq 7$$

$$x + 2y \leq 12 \tag{5.10}$$

$$2x + y \leq 12 \tag{5.11}$$

$$x \geq 0; y \geq 0 \tag{5.12}$$

In order to solve the problem, we graph the constraints as follows:

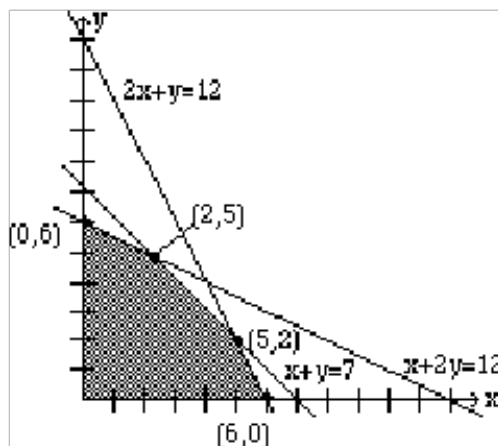

Figure 5.2

Again, we have shaded the feasibility region, where all constraints are satisfied.

Since the extreme value of the objective function always takes place at the vertices of the feasibility region, we identify all the critical points. They are listed as $(0, 0)$, $(0, 6)$, $(2, 5)$, $(5, 2)$, and $(6, 0)$. To maximize profit, we will substitute these points in the objective function to see which point gives us the maximum profit each day. The results are listed below.

Critical point	Income
(0,0)	$20(0) + 30(0) = \$0$
(0,6)	$20(0) + 30(6) = \$180$
(2,5)	$20(2) + 30(5) = \$190$
(5,2)	$20(5) + 30(2) = \$160$
(6,0)	$20(6) + 30(0) = \$120$

Table 5.2

The point (2, 5) gives the most profit, and that profit is \$190. Therefore, we conclude that we should manufacture 2 regular gadgets and 5 premium gadgets daily for a profit of \$190.

Although we are mostly focusing on the standard maximization problems where all constraints are of the form $ax + by \leq 0$, we will now consider an example where that is not the case.

Example 5.3

Solve the following maximization problem graphically.

Maximize $P = 10x + 15y$

Subject to: $x + y \geq 1$

$$x + 2y \leq 6 \tag{5.13}$$

$$2x + y \leq 6 \tag{5.14}$$

$$x \geq 0; y \geq 0 \tag{5.15}$$

Solution

The graph is shown below.

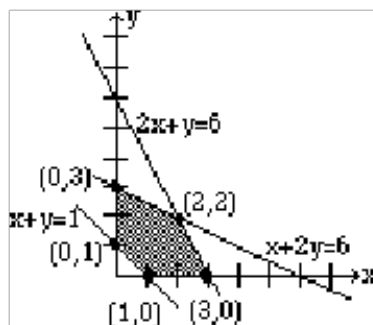

Figure 5.3

The five critical points are listed in the above figure. Clearly, the point $(2, 2)$ maximizes the objective function to a maximum value of 50. The reader should observe that the first constraint $x + y \geq 1$ requires that feasibility region must be bounded below by the line $x + y = 1$.

Finally, we address an important question. Is it possible to determine the point that gives the maximum value without calculating the value at each critical point?

The answer is yes.

For example, in the above problem, we substituted the points $(0, 0)$, $(0, 6)$, $(2, 5)$, $(5, 2)$, and $(6, 0)$, in the objective function $P = 20x + 30y$, and we got the values \$0, \$180, \$190, \$160, \$120, respectively. Sometimes that is not the most efficient way of finding the optimum solution.

To determine the largest P , we graph $P = 20x + 30y$ for any value P of our choice. Let us say, we choose $P = 60$. We graph $20x + 30y = 60$. Now we move the line parallel to itself, that is, keeping the same slope at all times. Since we are moving the line parallel to itself, the slope is kept the same, and the only thing that is changing is the P . As we move away from the origin, the value of P increases. The largest value of P is realized when the line touches the last corner point. The figure below shows the movements of the line, and the optimum solution is achieved at the point $(2, 5)$. In maximization problems, as the line is being moved away from the origin, this optimum point is the farthest critical point.

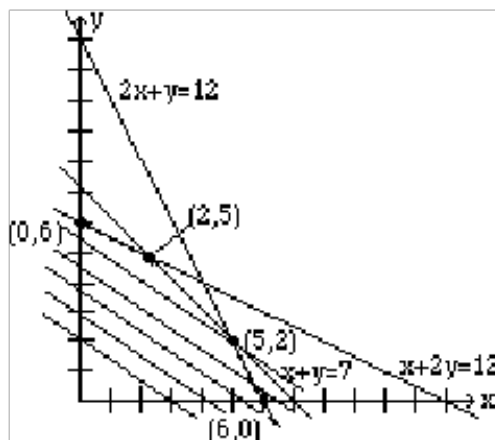

Figure 5.4

We summarize:

5.4: The Maximization Linear Programming Problems

1. Write the objective function.
2. Write the constraints.
 - a) For the standard maximization linear programming problems, constraints are of the form: $ax + by \leq c$
 - b) Since the variables are non-negative, we include the constraints: $x \geq 0; y \geq 0$.
3. Graph the constraints.
4. Shade the feasibility region.
5. Find the corner points.
6. Determine the corner point that gives the maximum value.
 - a) This is done by finding the value of the objective function at each corner point.
 - b) This can also be done by moving the line associated with the objective function.

5.3 Minimization Applications

Minimization linear programming problems are solved in much the same way as the maximization problems. For the standard minimization linear programming problem, the constraints are of the form $ax + by \geq c$, as opposed to the form $ax + by \leq c$ for the standard maximization problem. As a result, the feasible solution extends indefinitely to the upper right of the first quadrant, and is unbounded. But that is not a concern, since in order to minimize the objective function, the line associated with the objective function is moved towards the origin, and the critical point that minimizes the function is closest to the origin.

However, one should be aware that in the case of an unbounded feasibility region, the possibility of no optimal solution exists.

Example 5.5

Professor Symons wishes to employ two students, John and Mary, to grade the homework papers for his classes. John can mark 20 papers per hour and charges \$5 per hour, and Mary can mark 30 papers per hour and charges \$8 per hour. Each student must be employed at least one hour a week to justify their employment. If Mr. Symons has at least 110 homework papers to be marked each week, how many hours per week should he employ each student to minimize his cost?

Solution

We choose the variables as follows:

Let x = The number of hours per week John is employed.

and y = The number of hours per week Mary is employed.

The objective function is

$$C = 5x + 8y \quad (5.16)$$

The fact that each student must work at least one hour each week results in the following two constraints:

$$x \geq 1 \quad (5.17)$$

$$y \geq 1 \quad (5.18)$$

Since John can grade 20 papers per hour and Mary 30 papers per hour, and there are at least 110 papers to be graded per week, we get

$$20x + 30y \geq 110 \quad (5.19)$$

The fact that x and y are non-negative, we get

$x \geq 0$, and $y \geq 0$.

The problem has been formulated as follows.

Minimize $C = 5x + 8y$

Subject to: $x \geq 1$

$$y \geq 1 \quad (5.20)$$

$$20x + 30y \geq 110 \quad (5.21)$$

$$x \geq 0; y \geq 0 \quad (5.22)$$

To solve the problem, we graph the constraints as follows:

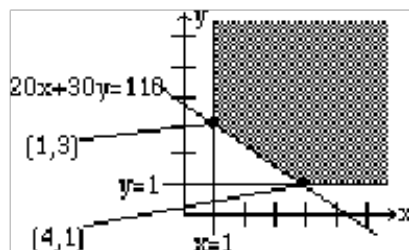

Figure 5.5

Again, we have shaded the feasibility region, where all constraints are satisfied.

Since the extreme value of the objective function always takes place at the vertices of the feasibility region, we identify the two critical points, $(1, 3)$ and $(4, 1)$. To minimize cost, we will substitute these points in the objective function to see which point gives us the minimum cost each week. The results are listed below.

Critical Points	Income
$(1, 3)$	$5(1) + 8(3) = \$29$
$(4, 1)$	$5(4) + 8(1) = \$28$

Table 5.3

The point $(4, 1)$ gives the least cost, and that cost is \$28. Therefore, we conclude that Professor Symons should employ John 4 hours a week, and Mary 1 hour a week at a cost of \$28 per week.

Example 5.6

Professor Hamer is on a low cholesterol diet. During lunch at the college cafeteria, he always chooses between two meals, Pasta or Tofu. The table below lists the amount of protein, carbohydrates, and vitamins each meal provides along with the amount of cholesterol he is trying to minimize. Mr. Hamer needs at least 200 grams of protein, 960 grams of carbohydrates, and 40 grams of vitamins for lunch each month. Over this time period, how many days should he have the Pasta meal, and how many days the Tofu meal so that he gets the adequate amount of protein, carbohydrates, and vitamins and at the same time minimizes his cholesterol intake?

	Pasta	Tofu
Protein	8g	16g
Carbohydrates	60g	40g
Vitamin C	2g	2g
Cholesterol	60mg	50mg

Table 5.4

Solution

We choose the variables as follows.

Let x = The number of days Mr. Hamer eats Pasta.

and y = The number of days Mr. Hamer eats Tofu.

Since he is trying to minimize his cholesterol intake, our objective function represents the total amount of cholesterol C provided by both meals.

$$C = 60x + 50y \quad (5.23)$$

The constraint associated with the total amount of protein provided by both meals is as follows:

$$8x + 16y \geq 200 \quad (5.24)$$

Similarly, the two constraints associated with the total amount of carbohydrates and vitamins are obtained, and they are

$$60x + 40y \geq 960 \quad (5.25)$$

$$2x + 2y \geq 40 \quad (5.26)$$

The constraints that state that x and y are non-negative are

$$x \geq 0, \text{ and } y \geq 0 \quad (5.27)$$

We summarize all information as follows:

Minimize $C = 60x + 50y$

Subject to: $8x + 16y \geq 200$

$$60x + 40y \geq 960 \quad (5.28)$$

$$2x + 2y \geq 40 \quad (5.29)$$

$$x \geq 0; y \geq 0 \quad (5.30)$$

To solve the problem, we graph the constraints as follows.

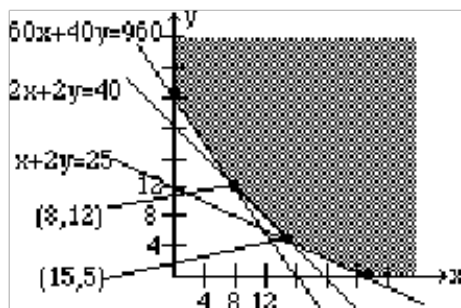

Figure 5.6

Again, we have shaded the unbounded feasibility region, where all constraints are satisfied.

To minimize the objective function, we find the vertices of the feasibility region. These vertices are $(0, 24)$, $(8, 12)$, $(15, 5)$ and $(25, 0)$. To minimize cholesterol, we will substitute these points in the objective function to see which point gives us the smallest value. The results are listed below.

Critical Points	Income
$(0, 24)$	$60(0) + 50(24) = 1200$
$(8, 12)$	$60(8) + 50(12) = 1080$
$(15, 5)$	$60(15) + 50(5) = 1150$
$(25, 0)$	$60(25) + 50(0) = 1500$

Table 5.5

The point $(8, 12)$ gives the least cholesterol, which is 1080 mg. This states that for every 20 meals, Professor Hamer should eat Pasta 8 days, and Tofu 12 days.

Although the method of solving minimization problems is similar to that of the maximization problems, we still feel that we should summarize the steps involved.

5.7: Minimization Linear Programming Problems

1. Write the objective function.
2. Write the constraints.
 - a) For standard minimization linear programming problems, constraints are of the form:
 $ax + by \geq c$
 - b) Since the variables are non-negative, include the constraints: $x \geq 0$; $y \geq 0$.
3. Graph the constraints.
4. Shade the feasibility region.
5. Find the corner points.
6. Determine the corner point that gives the minimum value.

- a) This can be done by finding the value of the objective function at each corner point.
- b) This can also be done by moving the line associated with the objective function.
- c) There is the possibility that the problem has no solution.

Chapter 6

Linear Programming: A Geometrical Approach: Homework¹

6.1 MAXIMIZATION APPLICATIONS

For the following maximization problems, choose your variables, write the objective function and the constraints, graph the constraints, shade the feasibility region, label all critical points, and determine the solution that optimizes the objective function.

Exercise 6.1

(Solution on p. 113.)

A farmer has 100 acres of land on which she plans to grow wheat and corn. Each acre of wheat requires 4 hours of labor and \$20 of capital, and each acre of corn requires 16 hours of labor and \$40 of capital. The farmer has at most 800 hours of labor and \$2400 of capital available. If the profit from an acre of wheat is \$80 and from an acre of corn is \$100, how many acres of each crop should she plant to maximize her profit?

Exercise 6.2

Mr. Tran has \$24,000 to invest, some in bonds and the rest in stocks. He has decided that the money invested in bonds must be at least twice as much as that in stocks. But the money invested in bonds must not be greater than \$18,000. If the bonds earn 6%, and the stocks earn 8%, how much money should he invest in each to maximize profit?

Exercise 6.3

(Solution on p. 113.)

A factory manufactures chairs and tables, each requiring the use of three operations: Cutting, Assembly, and Finishing. The first operation can be used at most 40 hours; the second at most 42 hours; and the third at most 25 hours. A chair requires 1 hour of cutting, 2 hours of assembly, and 1 hour of finishing; a table needs 2 hours of cutting, 1 hour of assembly, and 1 hour of finishing. If the profit is \$20 per unit for a chair and \$30 for a table, how many units of each should be manufactured to maximize revenue?

Exercise 6.4

The Silly Nut Company makes two mixtures of nuts: Mixture A and Mixture B. A pound of Mixture A contains 12 oz of peanuts, 3 oz of almonds and 1 oz of cashews and sells for \$4. A pound of Mixture B contains 12 oz of peanuts, 2 oz of almonds and 2 oz of cashews and sells for \$5. The company has 1080 lb. of peanuts, 240 lb. of almonds, 160 lb. of cashews. How many pounds of each of mixtures A and B should the company make to maximize profit?

¹This content is available online at <http://cnx.org/content/m38650/1.1/>.

6.2 MINIMIZATION APPLICATIONS

For each of the following minimization problems, choose your variables, write the objective function and the constraints, graph the constraints, shade the feasibility region, label all critical points, and determine the solution that optimizes the objective function.

Exercise 6.5*(Solution on p. 113.)*

A diet is to contain at least 2400 units of vitamins, 1800 units of minerals, and 1200 calories. Two foods, Food A and Food B are to be purchased. Each unit of Food A provides 50 units of vitamins, 30 units of minerals, and 10 calories. Each unit of Food B provides 20 units of vitamins, 20 units of minerals, and 40 calories. If Food A costs \$2 per unit and Food B cost \$1 per unit, how many units of each food should be purchased to keep costs at a minimum?

Exercise 6.6

A computer store sells two types of computers, desktops and laptops. The supplier demands that at least 150 computers be sold a month. In order to keep profits up, the number of desktops sold must be at least twice of laptops. The store pays its sales staff a \$75 commission for each desk top, and a \$50 commission for each lap top. How many of each type of computers must be sold to minimize commission to its sales people? What is the minimum commission?

Exercise 6.7*(Solution on p. 113.)*

An oil company has two refineries. Each day, Refinery A produces 200 barrels of high-grade oil, 300 barrels of medium-grade oil, and 200 barrels of low-grade oil and costs \$12,000 to operate. Each day, Refinery B produces 100 barrels of high-grade oil, 100 barrels of medium-grade oil, and 200 barrels of low-grade oil and costs \$10,000 to operate. The company must produce at least 800 barrels of high-grade oil, 900 barrels of medium-grade oil, and 1,000 barrels of low-grade oil. How many days should each refinery be operated to meet the goals at a minimum cost?

Exercise 6.8

A print shop at a community college in Cupertino, California, employs two different contractors to maintain its copying machines. The print shop needs to have 12 IBM, 18 Xerox, and 20 Canon copying machines serviced. Contractor A can repair 2 IBM, 1 Xerox, and 2 Canon machines at a cost of \$800 per month, while Contractor B can repair 1 IBM, 3 Xerox, and 2 Canon machines at a cost of \$1000 per month. How many months should each of the two contractors be employed to minimize the cost?

6.3 CHAPTER REVIEW

Solve the following linear programming problems by the graphical method.

Exercise 6.9*(Solution on p. 113.)*

Mr. Shoemaker has \$20,000 to invest in two types of mutual funds, Coleman High-yield Fund, and Coleman Equity Fund. The High-yield fund gives an annual yield of 12%, while the Equity fund earns 8%. Mr. Shoemaker would like to invest at least \$3000 in the High-yield fund and at least \$4000 in the Equity fund. How much money should he invest in each to maximize his annual yield, and what is the maximum yield?

Exercise 6.10*(Solution on p. 113.)*

Dr. Lum teaches part-time at two different community colleges, Hilltop College and Serra College. Dr. Lum can teach up to 5 classes per semester. For every class taught by him at Hilltop College, he needs to spend 3 hours per week preparing lessons and grading papers, and for each class at Serra College, he must do 4 hours of work per week. He has determined that he cannot spend more than 18 hours per week preparing lessons and grading papers. If he earns \$4,000 per class at Hilltop College and \$5,000 per class at Serra College, how many classes should he teach at each college to maximize his income, and what will be his income?

Exercise 6.11*(Solution on p. 113.)*

Mr. Shamir employs two part-time typists, Inna and Jim for his typing needs. Inna charges \$10 an hour and can type 6 pages an hour, while Jim charges \$12 an hour and can type 8 pages per hour. Each typist must be employed at least 8 hours per week to keep them on the payroll. If Mr. Shamir has at least 208 pages to be typed, how many hours per week should he employ each student to minimize his typing costs, and what will be the total cost?

Exercise 6.12*(Solution on p. 113.)*

Mr. Boutros wants to invest up to \$20,000 in two stocks, Cal Computers and Texas Tools. The Cal Computers stock is expected to yield a 16% annual return, while the Texas Tools stock promises a 12% yield. Mr. Boutros would like to earn at least \$2,880 this year. According to Value Line Magazine's safety index (1 highest to 5 lowest), Cal Computers has a safety number of 3 and Texas Tools has a safety number of 2. How much money should he invest in each to minimize the safety number? Note: A lower safety number means less risk.

Exercise 6.13*(Solution on p. 113.)*

A department store sells two types of televisions: Regular and Big Screen. The store can sell up to 90 sets a month. A Regular television requires 6 cubic feet of storage space, and a Big Screen television requires 18 cubic feet of space, and a maximum of 1080 cubic feet of storage space is available. The Regular and Big Screen televisions take up, respectively, 2 and 3 sales hours of labor, and a maximum of 198 hours of labor is available. If the profit made from each of these types is \$60 and \$80, respectively, how many of each type of television should be sold to maximize profit, and what is the maximum profit?

Exercise 6.14*(Solution on p. 113.)*

A company manufactures two types of printers, the Inkjet and the Laser. The Inkjet generates a profit of \$100 per printer and the Laser a profit of \$150. On the assembly line the Inkjet requires 7 hours, while the Laser takes 11 hours. Both printers require one hour for testing. The Inkjet requires one hour and the Laser needs 3 hours for finishing. On a particular production run the company has available 1,540 work hours on the assembly line, 200 work hours in the testing department, and 360 work hours for finishing. How many sets of each type should the company produce to maximize profit, and what is that maximum profit?

Exercise 6.15*(Solution on p. 113.)*

John wishes to choose a combination of two types of cereals for breakfast - Cereal A and Cereal B. A small box(one serving) of Cereal A costs \$0.50 and contains 10 units of vitamins, 5 units of minerals, and 15 calories. A small box(one serving) of Cereal B costs \$0.40 and contains 5 units of vitamins, 10 units of minerals, and 15 calories. John wants to buy enough boxes to have at least 500 units of vitamins, 600 units of minerals, and 1200 calories. How many boxes of each food should he buy to minimize his cost, and what is the minimum cost?

Exercise 6.16*(Solution on p. 113.)*

Jessica needs at least 60 units of vitamin A, 40 units of vitamin B, and 140 units of vitamin C each week. She can choose between Costless brand or Savemore brand tablets. A Costless tablet costs 5 cents and contains 3 units of vitamin A, 1 unit of vitamin B, and 2 units of vitamin C, and a Savemore tablet costs 7 cents and contains 1 unit of A, 1 of B, and 5 of C. How many tablets of each kind should she buy to minimize cost, and what is the minimum cost?

Exercise 6.17*(Solution on p. 113.)*

A small company manufactures two types of radios- regular and short-wave. The manufacturing of each radio requires three operations: Assembly, Finishing and Testing. The regular radios require 1 hour of Assembly, 3 hours of Finishing, and 1 hour of Testing. The short-wave radios require 3 hours of Assembly, 1 hour of Finishing, and 1 hour of Testing. The total work-hours available per week in the Assembly division is 60, in the Finishing division is 60, and in the Testing is 24. If a profit of \$50 is realized for every regular radio, and \$75 for every short-wave radio, how many of each should be manufactured to maximize profit, and what is the maximum profit?

Exercise 6.18*(Solution on p. 113.)*

A factory manufactures two products, A and B. Each product requires the use of three machines, Machine I, Machine II, and Machine III. The time requirements and total hours available on each machine are listed below.

	Machine I	Machine II	Machine III
Product A	1	2	4
Product B	2	2	2
Total hours	70	90	160

Table 6.1

If product A generates a profit of \$60 per unit and product B a profit of \$50 per unit, how many units of each product should be manufactured to maximize profit, and what is the maximum profit?

Exercise 6.19*(Solution on p. 113.)*

A company produces three types of shoes, formal, casual, and athletic, at its two factories, Factory I and Factory II. Daily production of each factory for each type of shoe is listed below.

	Factory I	Factory II
Formal	100	100
Casual	100	200
Athletic	300	100

Table 6.2

The company must produce at least 6000 pairs of formal shoes, 8000 pairs of casual shoes, and 9000 pairs of athletic shoes. If the cost of operating Factory I is \$1500 per day and the cost of operating Factory II is \$2000, how many days should each factory operate to complete the order at a minimum cost, and what is the minimum cost?

Exercise 6.20*(Solution on p. 113.)*

A professor gives two types of quizzes, objective and recall. He is planning to give at least 15 quizzes this quarter. The student preparation time for an objective quiz is 15 minutes and for a recall quiz 30 minutes. The professor would like a student to spend at least 5 hours (300 minutes) preparing for these quizzes above and beyond the normal study time. The average score on an objective quiz is 7, and on a recall type 5, and the professor would like the students to score at least 85 points on all quizzes. It takes the professor one minute to grade an objective quiz, and 1.5 minutes to grade a recall type quiz. How many of each type should he give in order to minimize his grading time?

Exercise 6.21*(Solution on p. 113.)*

A company makes two mixtures of nuts: Mixture A and Mixture B. Mixture A contains 30% peanuts, 30% almonds and 40% cashews and sells for \$5 per pound. Mixture B contains 30% peanuts, 60% almonds and 10% cashews and sells for \$3 a pound. The company has 540 pounds of peanuts, 900 pounds of almonds, 480 pounds of cashews. How many pounds of each of mixtures A and B should the company make to maximize profit, and what is the maximum profit?

Solutions to Exercises in Chapter 6

Solutions to Linear Programming: A Geometrical Approach: Homework

Solution to Exercise 6.1 (p. 109)

80 acres of wheat and 20 acres of corn should be planted to maximize profit to \$8,400

Solution to Exercise 6.3 (p. 109)

10 chairs and 15 tables should be manufactured to maximize profit to \$650.

Solution to Exercise 6.5 (p. 110)

30 units of Food A and 45 units of Food B should be purchased to keep costs at a minimum of \$105.

Solution to Exercise 6.7 (p. 110)

Cost: $C = 12,000x + 10,000y$

- I. $200x + 100y \geq 800$ high-grade oil
- II. $300x + 100y \geq 900$ medium-grade oil
- III. $200x + 200y \geq 1000$ low-grade oil

Refinery A should be operated for 3 days, while Refinery B should be operated for 2 days to keep a minimum cost of \$56,000.

Solution to Exercise 6.9 (p. 110)

(16000, 4000); \$2240

Solution to Exercise 6.10 (p. 110)

(2, 3); \$23,000

Solution to Exercise 6.11 (p. 111)

(8, 20); \$320

Solution to Exercise 6.12 (p. 111)

(12000, 8000)

Solution to Exercise 6.13 (p. 111)

(72, 180); \$5760

Solution to Exercise 6.14 (p. 111)

(165, 35); \$21,750

Solution to Exercise 6.15 (p. 111)

(20, 60); \$34

Solution to Exercise 6.16 (p. 111)

(20, 20); \$2.40

Solution to Exercise 6.17 (p. 111)

(6, 18); \$1650

Solution to Exercise 6.18 (p. 112)

(35, 100); \$2600

Solution to Exercise 6.19 (p. 112)

(40, 20); \$100,000

Solution to Exercise 6.20 (p. 112)

(10, 5): 17.5 minutes

Solution to Exercise 6.21 (p. 112)

(1000, 800); \$7400

Chapter 7

Linear Programming: The Simplex Method¹

7.1 Chapter Overview

In this chapter, you will learn to:

1. Solve linear programming maximization problems using the simplex method.
2. Solve the minimization problems using the simplex method.

7.2 Maximization By The Simplex Method

In the last chapter, we used the geometrical method to solve linear programming problems, but the geometrical approach will not work for problems that have more than two variables. In real life situations, linear programming problems consist of literally thousands of variables and are solved by computers. We can solve these problems algebraically, but that will not be very efficient. Suppose we were given a problem with, say, 5 variables and 10 constraints. By choosing all combinations of five equations with five unknowns, we could find all the corner points, test them for feasibility, and come up with the solution, if it exists. But the trouble is that even for a problem with so few variables, we will get more than 250 corner points, and testing each point will be very tedious. So we need a method that has a systematic algorithm and can be programmed for a computer. The method has to be efficient enough so we wouldn't have to evaluate the objective function at each corner point. We have just such a method, and it is called the **simplex method**.

The simplex method was developed during the Second World War by Dr. George Dantzig. His linear programming models helped the Allied forces with transportation and scheduling problems. In 1979, a Soviet scientist named Leonid Khachian developed a method called the ellipsoid algorithm which was supposed to be revolutionary, but as it turned out it is not any better than the simplex method. In 1984, Narendra Karmarkar, a research scientist at AT&T Bell Laboratories developed Karmarkar's algorithm which has been proven to be four times faster than the simplex method for certain problems. But the simplex method still works the best for most problems.

The simplex method uses an approach that is very efficient. It does not compute the value of the objective function at every point, instead, it begins with a corner point of the feasibility region where all the main variables are zero and then systematically moves from corner point to corner point, while improving the value of the objective function at each stage. The process continues until the optimal solution is found.

To learn the simplex method, we try a rather unconventional approach. We first list the algorithm, and then work a problem. We justify the reasoning behind each step during the process. A thorough justification

¹This content is available online at <<http://cnx.org/content/m18904/1.2/>>.

is beyond the scope of this course.

We start out with an example we solved in the last chapter by the graphical method. This will provide us with some insight into the simplex method and at the same time give us the chance to compare a few of the feasible solutions we obtained previously by the graphical method.

But first, we list the algorithm for the simplex method.

7.1: THE SIMPLEX METHOD

1. **Set up the problem.** That is, write the objective function and the constraints.
2. **Convert the inequalities into equations.** This is done by adding one slack variable for each inequality.
3. **Construct the initial simplex tableau.** Write the objective function as the bottom row.
4. **The most negative entry in the bottom row identifies a column.**
5. **Calculate the quotients. The smallest quotient identifies a row. The element in the intersection of the column identified in step 4 and the row identified in this step is identified as the pivot element.** The quotients are computed by dividing the far right column by the identified column in step 4. A quotient that is a zero, or a negative number, or that has a zero in the denominator, is ignored.
6. **Perform pivoting to make all other entries in this column zero.** This is done the same way as we did with the Gauss-Jordan method.
7. **When there are no more negative entries in the bottom row, we are finished; otherwise, we start again from step 4.**
8. **Read off your answers.** Get the variables using the columns with 1 and 0s. All other variables are zero. The maximum value you are looking for appears in the bottom right hand corner.

And now, Example 5.1 we solved in Section 5.2 (Maximization Applications).

Example 7.2

Problem 1

Niki holds two part-time jobs, Job I and Job II. She never wants to work more than a total of 12 hours a week. She has determined that for every hour she works at Job I, she needs 2 hours of preparation time, and for every hour she works at Job II, she needs one hour of preparation time, and she cannot spend more than 16 hours for preparation. If she makes \$40 an hour at Job I, and \$30 an hour at Job II, how many hours should she work per week at each job to maximize her income?

Solution

In solving this problem, we will follow the algorithm listed above.

1. **Set up the problem.** That is, write the objective function and the constraints. Since the simplex method is used for problems that consist of many variables, it is not practical to use the variables x , y , z etc. We use the symbols x_1 , x_2 , x_3 , and so on.
Let x_1 = The number of hours per week Niki will work at Job I.
and x_2 = The number of hours per week Niki will work at Job II.
It is customary to choose the variable that is to be maximized as Z .
The problem is formulated the same way as we did in the Chapter 5.
Maximize $Z = 40x_1 + 30x_2$
Subject to: $x_1 + x_2 \leq 12$

$$2x_1 + x_2 \leq 16 \tag{7.1}$$

$$x_1 \geq 0 ; x_2 \geq 0 \tag{7.2}$$

2. **Convert the inequalities into equations.** This is done by adding one slack variable for each inequality. For example to convert the inequality $x_1 + x_2 \leq 12$ into an equation, we add a non-negative variable y_1 , and we get

$$x_1 + x_2 + y_1 = 12 \quad (7.3)$$

Here the variable y_1 picks up the slack, and it represents the amount by which $x_1 + x_2$ falls short of 12. In this problem, if Niki works fewer than 12 hours, say 10, then y_1 is 2. Later when we read off the final solution from the simplex table, the values of the slack variables will identify the unused amounts.

We can even rewrite the objective function $Z = 40x_1 + 30x_2$ as $-40x_1 - 30x_2 + Z = 0$.

After adding the slack variables, our problem reads

Objective function: $-40x_1 - 30x_2 + Z = 0$

Subject to constraints: $x_1 + x_2 + y_1 = 12$

$$2x_1 + x_2 + y_2 = 16 \quad (7.4)$$

$$x_1 \geq 0 ; x_2 \geq 0 \quad (7.5)$$

3. **Construct the initial simplex tableau.** Write the objective function as the bottom row. Now that the inequalities are converted into equations, we can represent the problem into an augmented matrix called the initial simplex tableau as follows.

x_1	x_2	y_1	y_2	Z	C
1	1	1	0	0	12
2	1	0	1	0	16
-40	-30	0	0	1	0

Figure 7.1

Here the vertical line separates the left hand side of the equations from the right side. The horizontal line separates the constraints from the objective function. The right side of the equation is represented by the column C .

The reader needs to observe that the last four columns of this matrix look like the final matrix for the solution of a system of equations. If we arbitrarily choose $x_1 = 0$ and $x_2 = 0$, we get

$$\left[\begin{array}{ccc|c} y_1 & y_2 & Z & C \\ 1 & 0 & 0 & 12 \\ 0 & 1 & 0 & 16 \\ 0 & 0 & 1 & 0 \end{array} \right] \quad (7.6)$$

Which reads

$$y_1 = 12 \quad (7.7)$$

$$y_2 = 16 \quad (7.8)$$

$$Z = 0 \tag{7.9}$$

The solution obtained by arbitrarily assigning values to some variables and then solving for the remaining variables is called the **basic solution** associated with the tableau. So the above solution is the basic solution associated with the initial simplex tableau. We can label the basic solution variable in the right of the last column as shown in the table below.

x_1	x_2	y_1	y_2	Z		
1	1	1	0	0	12	y_1
2	1	0	1	0	16	y_2
-40	-30	0	0	1	0	Z

Figure 7.2

4. **The most negative entry in the bottom row identifies a column.** The most negative entry in the bottom row is -40 , therefore the column 1 is identified.

x_1	x_2	y_1	y_2	Z		
1	1	1	0	0	12	y_1
2	1	0	1	0	16	y_2
-40	-30	0	0	1	0	Z
↑						

Figure 7.3

Problem 2

Why do we choose the most negative entry in the bottom row?

Solution

The most negative entry in the bottom row represents the largest coefficient in the objective function – the coefficient whose entry will increase the value of the objective function the quickest.

The simplex method begins at a corner point where all the main variables, the variables that have symbols such as x_1 , x_2 , x_3 etc., are zero. It then moves from a corner point to the adjacent corner point always increasing the value of the objective function. In the case of the objective function $Z = 40x_1 + 30x_2$, it will make more sense to increase the value of x_1 rather than x_2 . The variable x_1 represents the number of hours per week Niki works at Job I. Since Job I pays \$40 per hour as opposed to Job II which pays only \$30, the variable x_1 will increase the objective function by \$40 for a unit of increase in the variable x_1 .

5. **Calculate the quotients. The smallest quotient identifies a row. The element in the intersection of the column identified in step 4 and the row identified in this step is identified as the pivot element.** As mentioned in the algorithm, in order to calculate the quotient, we divide the entries in the far right column by the entries in column 1, excluding the entry in the bottom row.

x_1	x_2	y_1	y_2	Z			
1	1	1	0	0	12	y_1	$12 \div 1 = 12$
2	1	0	1	0	16	y_2	$\leftarrow 16 \div 2 = 8$
-40	-30	0	0	1	0	Z	
↑							

Figure 7.4

The smallest of the two quotients, 12 and 8, is 8. Therefore row 2 is identified. The intersection of column 1 and row 2 is the entry 2, which has been highlighted. This is our pivot element.

Problem 3

Why do we find quotients, and why does the smallest quotient identify a row?

Solution

When we choose the most negative entry in the bottom row, we are trying to increase the value of the objective function by bringing in the variable x_1 . But we cannot choose any value for x_1 . Can we let $x_1 = 100$? Definitely not! That is because Niki never wants to work for more than 12 hours at both jobs combined. In other words, $x_1 + x_2 \leq 12$. Now can we let $x_1 = 12$? Again, the answer is no because the preparation time for Job I is two times the time spent on the job. Since Niki never wants to spend more than 16 hours for preparation, the maximum time she can work is $16 \div 2 = 8$. Now you see the purpose of computing the quotients.

Problem 4

Why do we identify the pivot element?

Solution

As we have mentioned earlier, the simplex method begins with a corner point and then moves to the next corner point always improving the value of the objective function. The value of the objective function is improved by changing the number of units of the variables. We may add the number of units of one variable, while throwing away the units of another. Pivoting allows us to do just that.

The variable whose units are being added is called the **entering variable**, and the variable whose units are being replaced is called the **departing variable**. The entering variable in the above table is x_1 , and it was identified by the most negative entry in the bottom row. The departing variable y_2 was identified by the lowest of all quotients.

6. **Perform pivoting to make all other entries in this column zero.** In Chapter 3, we used pivoting to obtain the row echelon form of an augmented matrix. Pivoting is a process

of obtaining a 1 in the location of the pivot element, and then making all other entries zeros in that column. So now our job is to make our pivot element a 1 by dividing the entire second row by 2. The result follows.

x_1	x_2	y_1	y_2	Z		
1	1	1	0	0		12
1	1/2	0	1/2	0		8
-40	-30	0	0	1		0

Figure 7.5

To obtain a zero in the entry first above the pivot element, we multiply the second row by -1 and add it to row 1. We get

x_1	x_2	y_1	y_2	Z		
0	1/2	1	-1/2	0		4
1	1/2	0	1/2	0		8
-40	-30	0	0	1		0

Figure 7.6

To obtain a zero in the element below the pivot, we multiply the second row by 40 and add it to the last row.

x_1	x_2	y_1	y_2	Z		
0	1/2	1	-1/2	0		4 y_1
1	1/2	0	1/2	0		8 x_1
0	-10	0	20	1		320 Z

Figure 7.7

We now determine the basic solution associated with this tableau. By arbitrarily choosing $x_2 = 0$ and $y_2 = 0$, we obtain $x_1 = 8$, $y_1 = 4$, and $z = 320$. If we write the augmented matrix, whose left side is a matrix with columns that have one 1 and all other entries zeros, we get

the following matrix stating the same thing.

$$\left[\begin{array}{ccc|c} x_1 & y_1 & Z & C \\ 0 & 1 & 0 & 4 \\ 1 & 0 & 0 & 8 \\ 0 & 0 & 1 & 320 \end{array} \right] \quad (7.10)$$

We can restate the solution associated with this matrix as $x_1 = 8$, $x_2 = 0$, $y_1 = 4$, $y_2 = 0$ and $z = 320$. At this stage of the game, it reads that if Niki works 8 hours at Job I, and no hours at Job II, her profit Z will be \$320. Recall from Example 5.1 in Section 5.2 (Maximization Applications) that $(8, 0)$ was one of our corner points. Here $y_1 = 4$ and $y_2 = 0$ mean that she will be left with 4 hours of working time and no preparation time.

7. **When there are no more negative entries in the bottom row, we are finished; otherwise, we start again from step 4.** Since there is still a negative entry, -10 , in the bottom row, we need to begin, again, from step 4. This time we will not repeat the details of every step, instead, we will identify the column and row that give us the pivot element, and highlight the pivot element. The result is as follows.

x_1	x_2	y_1	y_2	Z				
0	$1/2$	1	$-1/2$	0	4	y_1	$\leftarrow 4 \div 1/2 = 8$	
1	$1/2$	0	$1/2$	0	8	x_1	$8 \div 1/2 =$	16
0	-10	0	20	1	320	Z		
	\uparrow							

Figure 7.8

We make the pivot element 1 by multiplying row 1 by 2, and we get

x_1	x_2	y_1	y_2	Z		
0	1	2	-1	0	8	
1	$1/2$	0	$1/2$	0	8	
0	-10	0	20	1	320	

Figure 7.9

Now to make all other entries as zeros in this column, we first multiply row 1 by $-1/2$ and add it to row 2, and then multiply row 1 by 10 and add it to the bottom row.

x_1	x_2	y_1	y_2	Z		
0	1	2	-1	0	8	x_2
1	0	-1	1	0	4	x_1
0	0	20	10	1	400	Z

Figure 7.10

We no longer have negative entries in the bottom row, therefore we are finished.

Problem 5

Why are we finished when there are no negative entries in the bottom row?

Solution

The answer lies in the bottom row. The bottom row corresponds to the following equation.

$$0x_1 + 0x_2 + 20y_1 + 10y_2 + Z = 400 \quad \text{or} \quad (7.11)$$

$$Z = 400 - 20y_1 - 10y_2 \quad (7.12)$$

Since all variables are non-negative, the highest value Z can ever achieve is 400, and that will happen only when y_1 and y_2 are zero.

8. **Read off your answers.** We now read off our answers, that is, we determine the basic solution associated with the final simplex tableau. Again, we look at the columns that have a 1 and all other entries zeros. Since the columns labeled y_1 and y_2 are not such columns, we arbitrarily choose $y_1 = 0$, and $y_2 = 0$, and we get

$$\left[\begin{array}{ccc|c} x_1 & x_2 & Z & C \\ 0 & 1 & 0 & 8 \\ 1 & 0 & 0 & 4 \\ 0 & 0 & 1 & 400 \end{array} \right] \quad (7.13)$$

The matrix reads $x_1 = 4$, $x_2 = 8$ and $z = 400$.

The final solution says that if Niki works 4 hours at Job I and 8 hours at Job II, she will maximize her income to \$400. Since both slack variables are zero, it means that she would have used up all the working time, as well as the preparation time, and none will be left.

7.3 Minimization By The Simplex Method

In this section, we will solve the standard linear programming minimization problems using the simplex method. Once again, we remind the reader that in the standard minimization problems all constraints are of the form $ax + by \geq c$. The procedure to solve these problems was developed by Dr. John Von Neuman. It involves solving an associated problem called the **dual problem**. To every minimization problem there

corresponds a dual problem. The solution of the dual problem is used to find the solution of the original problem. The dual problem is really a maximization problem which we already learned to solve in the Section 7.2 (Maximization By The Simplex Method). We will first solve the dual problem by the simplex method and then, from the final simplex tableau, we will extract the solution to the original minimization problem.

Before we go any further, however, we first learn to convert a minimization problem into its corresponding maximization problem called its dual.

Example 7.3

Convert the following minimization problem into its dual.

Minimize $Z = 12x_1 + 16x_2$

Subject to: $x_1 + 2x_2 \geq 40$

$$x_1 + x_2 \geq 30 \tag{7.14}$$

$$x_1 \geq 0; x_2 \geq 0 \tag{7.15}$$

Solution

To achieve our goal, we first express our problem as the following matrix.

1	2	40
1	1	30
12	16	0

Figure 7.11

Observe that this table looks like an initial simplex tableau without the slack variables. Next, we write a matrix whose columns are the rows of this matrix, and the rows are the columns. Such a matrix is called a **transpose** of the original matrix. We get

1	1	12
2	1	16
40	30	0

Figure 7.12

The following maximization problem associated with the above matrix is called its dual.

Maximize $Z = 40y_1 + 30y_2$

Subject to: $y_1 + y_2 \leq 12$

$$2y_1 + y_2 \leq 16 \tag{7.16}$$

$$y_1 \geq 0; y_2 \geq 0 \quad (7.17)$$

We have chosen the variables as y 's, instead of x 's, to distinguish the two problems.

Example 7.4

Solve graphically both the minimization problem and its dual, the maximization problem.

Solution

Our minimization problem is as follows.

$$\text{Minimize } Z = 12x_1 + 16x_2$$

$$\text{Subject to: } x_1 + 2x_2 \geq 40$$

$$x_1 + x_2 \geq 30 \quad (7.18)$$

$$x_1 \geq 0; x_2 \geq 0 \quad (7.19)$$

We now graph the inequalities.

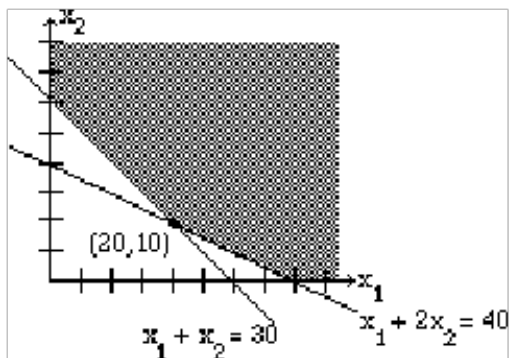

Figure 7.13

We have plotted the graph, shaded the feasibility region, and labeled the corner points. The corner point $(20, 10)$ gives the lowest value for the objective function and that value is 400.

Now its dual.

$$\text{Maximize } Z = 40y_1 + 30y_2$$

$$\text{Subject to: } y_1 + y_2 \leq 12$$

$$2y_1 + y_2 \leq 16$$

$$y_1 \geq 0; y_2 \geq 0$$

We graph the inequalities.

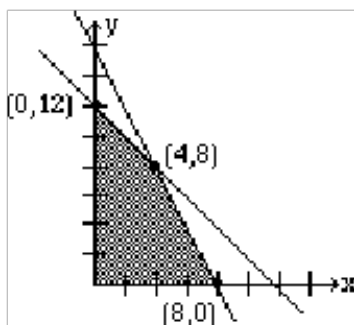

Figure 7.14

Again, we have plotted the graph, shaded the feasibility region, and labeled the corner points. The corner point $(4, 8)$ gives the highest value for the objective function, with a value of 400.

The reader may recognize that this problem is the same as Example 5.1, in Section 5.2 (Maximization Applications). This is also the same problem as Section 7.2 (Maximization By The Simplex Method) in Example 7.2, where we solved it by the simplex method.

We observe that the minimum value of the minimization problem is the same as the maximum value of the maximization problem; they are both 400. This is not a coincidence. We state the duality principle.

Definition 7.1: The Duality Principle:

The objective function of the minimization problem reaches its minimum if and only if the objective function of its dual reaches its maximum. And when they do, they are equal.

Our next goal is to extract the solution for our minimization problem from the corresponding dual. To do this, we solve the dual by the simplex method.

Example 7.5

Find the solution to the minimization problem in Example 7.3 by solving its dual using the simplex method. We rewrite our problem.

$$\text{Minimize } Z = 12x_1 + 16x_2$$

$$\text{Subject to: } x_1 + 2x_2 \geq 40$$

$$x_1 + x_2 \geq 30 \tag{7.20}$$

$$x_1 \geq 0; x_2 \geq 0 \tag{7.21}$$

Solution

The dual is as follows:

$$\text{Maximize } Z = 40y_1 + 30y_2$$

$$\text{Subject to: } y_1 + y_2 \leq 12$$

$$2y_1 + y_2 \leq 16 \tag{7.22}$$

$$y_1 \geq 0; y_2 \geq 0 \quad (7.23)$$

Once again, we remind the reader that we solved the above problem by the simplex method in Section 7.2 (Maximization By The Simplex Method), in Example 7.2. Therefore, we will only show the initial and final simplex tableau.

The initial simplex tableau is

y1	y2	x1	x2	Z	C
1	1	1	0	0	12
2	1	0	1	0	16
-40	-30	0	0	1	0

Figure 7.15

Observe an important change. Here our main variables are y_1 and y_2 and the slack variables are x_1 and x_2 .

The final simplex tableau reads as follows:

y1	y2	x1	x2	Z	
0	1	2	-1	0	8
1	0	-1	1	0	4
0	0	20	10	1	400
		↑	↑		↑

Figure 7.16

A closer look at this table reveals that the x_1 and x_2 values along with the minimum value for the minimization problem can be obtained from the last row of the final tableau. We have highlighted these values by the arrows.

We restate the solution as follows:

The minimization problem has a minimum value of 400 at the corner point (20, 10).

We now summarize our discussion so far.

7.6: MINIMIZATION BY THE SIMPLEX METHOD

1. Set up the problem.
2. Write a matrix whose rows represent each constraint with the objective function as its bottom row.

3. Write the transpose of this matrix by interchanging the rows and columns.
4. Now write the dual problem associated with the transpose.
5. Solve the dual problem by the simplex method learned in Example 7.2.
6. The optimal solution is found in the bottom row of the final matrix in the columns corresponding to the slack variables, and the minimum value of the objective function is the same as the maximum value of the dual.

Chapter 8

Linear Programming: The Simplex Method: Homework¹

8.1 MAXIMIZATION BY THE SIMPLEX METHOD

Solve the following linear programming problems using the simplex method.

Exercise 8.1

(Solution on p. 133.)

$$\begin{aligned} &\text{Maximize } z = x_1 + 2x_2 + 3x_3 \\ &\text{subject to } \begin{aligned} x_1 + x_2 + x_3 &\leq 12 \\ 2x_1 + x_2 + 3x_3 &\leq 18 \\ x_1, x_2, x_3 &\geq 0 \end{aligned} \end{aligned}$$

Exercise 8.2

$$\begin{aligned} &\text{Maximize } z = x_1 + 2x_2 + x_3 \\ &\text{subject to } \begin{aligned} x_1 + x_2 &\leq 3 \\ x_2 + x_3 &\leq 4 \\ x_1 + x_3 &\leq 5 \end{aligned} \end{aligned}$$

$$x_1, x_2, x_3 \geq 0 \tag{8.1}$$

Exercise 8.3

(Solution on p. 133.)

A farmer has 100 acres of land on which she plans to grow wheat and corn. Each acre of wheat requires 4 hours of labor and \$20 of capital, and each acre of corn requires 16 hours of labor and \$40 of capital. The farmer has at most 800 hours of labor and \$2400 of capital available. If the profit from an acre of wheat is \$80 and from an acre of corn is \$100, how many acres of each crop should she plant to maximize her profit?

Exercise 8.4

A factory manufactures chairs, tables and bookcases each requiring the use of three operations: Cutting, Assembly, and Finishing. The first operation can be used at most 600 hours; the second at most 500 hours; and the third at most 300 hours. A chair requires 1 hour of cutting, 1 hour of assembly, and 1 hour of finishing; a table needs 1 hour of cutting, 2 hours of assembly, and 1 hour of finishing; and a bookcase requires 3 hours of cutting, 1 hour of assembly, and 1 hour of finishing. If the profit is \$20 per unit for a chair, \$30 for a table, and \$25 for a bookcase, how many units of each should be manufactured to maximize profit?

¹This content is available online at <<http://cnx.org/content/m38649/1.2/>>.

Exercise 8.5*(Solution on p. 133.)*

The Acme Apple company sells its Pippin, Macintosh, and Fuji apples in mixes. Box I contains 4 apples of each kind; Box II contains 6 Pippin, 3 Macintosh, and 3 Fuji; and Box III contains no Pippin, 8 Macintosh and 4 Fuji apples. At the end of the season, the company has altogether 2800 Pippin, 2200 Macintosh, and 2300 Fuji apples left. Determine the maximum number of boxes that the company can make.

8.2 MINIMIZATION BY THE SIMPLEX METHOD

In problems 1-2, convert each minimization problem into a maximization problem, the dual, and then solve by the simplex method.

Exercise 8.6*(Solution on p. 133.)*

$$\begin{aligned} \text{Minimize } z &= 6x_1 + 8x_2 \\ \text{subject to } 2x_1 + 3x_2 &\geq 7 \\ 4x_1 + 5x_2 &\geq 9 \\ x_1, x_2 &\geq 0 \end{aligned}$$

Exercise 8.7

$$\begin{aligned} \text{Minimize } z &= 5x_1 + 6x_2 + 7x_3 \\ \text{subject to } 3x_1 + 2x_2 + 3x_3 &\geq 10 \\ 4x_1 + 3x_2 + 5x_3 &\geq 12 \\ x_1, x_2, x_3 &\geq 0 \end{aligned}$$

In the next two problems, convert each minimization problem into a maximization problem, the dual, and then solve by the simplex method.

Exercise 8.8*(Solution on p. 133.)*

$$\begin{aligned} \text{Minimize } z &= 4x_1 + 3x_2 \\ \text{subject to } x_1 + x_2 &\geq 10 \\ 3x_1 + 2x_2 &\geq 24 \\ x, x_2 &\geq 0 \end{aligned}$$

Exercise 8.9

A diet is to contain at least 8 units of vitamins, 9 units of minerals, and 10 calories. Three foods, Food A, Food B, and Food C are to be purchased. Each unit of Food A provides 1 unit of vitamins, 1 unit of minerals, and 2 calories. Each unit of Food B provides 2 units of vitamins, 1 unit of minerals, and 1 calorie. Each unit of Food C provides 2 units of vitamins, 1 unit of minerals, and 2 calories. If Food A costs \$3 per unit, Food B costs \$2 per unit and Food C costs \$3 per unit, how many units of each food should be purchased to keep costs at a minimum?

8.3 CHAPTER REVIEW

Solve the following linear programming problems using the simplex method.

Exercise 8.10*(Solution on p. 133.)*

$$\begin{aligned} \text{Maximize } z &= 5x_1 + 3x_2 \\ \text{subject to } x_1 + x_2 &\leq 12 \\ 2x_1 + x_2 &\leq 16 \\ x_1 \geq 0; x_2 &\geq 0 \end{aligned}$$

Exercise 8.11*(Solution on p. 133.)*

$$\text{Maximize } z = 5x_1 + 8x_2$$

$$\begin{aligned} \text{subject to } & x_1 + 2x_2 \leq 30 \\ & 3x_1 + x_2 \leq 30 \\ & x_1 \geq 0; x_2 \geq 0 \end{aligned}$$

Exercise 8.12*(Solution on p. 133.)*

$$\begin{aligned} \text{Maximize } z &= 2x_1 + 3x_2 + x_3 \\ \text{subject to } & 4x_1 + 2x_2 + 5x_3 \leq 32 \\ & 2x_1 + 4x_2 + 3x_3 \leq 28 \\ & x_1, x_2, x_3 \geq 0 \end{aligned}$$

Exercise 8.13*(Solution on p. 133.)*

$$\begin{aligned} \text{Maximize } z &= x_1 + 6x_2 + 8x_3 \\ \text{subject to } & x_1 + 2x_2 \leq 1200 \\ & 2x_2 + x_3 \leq 1800 \\ & 4x_1 + x_3 \leq 3600 \\ & x_1, x_2, x_3 \geq 0 \end{aligned}$$

Exercise 8.14*(Solution on p. 133.)*

$$\begin{aligned} \text{Maximize } z &= 6x_1 + 8x_2 + 5x_3 \\ \text{subject to } & 4x_1 + x_2 + x_3 \leq 1800 \\ & 2x_1 + 2x_2 + x_3 \leq 2000 \\ & 4x_1 + 2x_2 + x_3 \leq 3200 \\ & x_1, x_2, x_3 \geq 0 \end{aligned}$$

Exercise 8.15*(Solution on p. 133.)*

$$\begin{aligned} \text{Minimize } z &= 12x_1 + 10x_2 \\ \text{subject to } & x_1 + x_2 \geq 6 \\ & 2x_1 + x_2 \geq 8 \\ & x_1 \geq 0; x_2 \geq 0 \end{aligned}$$

Exercise 8.16*(Solution on p. 133.)*

$$\begin{aligned} \text{Minimize } z &= 4x_1 + 6x_2 + 7x_3 \\ \text{subject to } & x_1 + x_2 + 2x_3 \geq 20 \\ & x_1 + 2x_2 + x_3 \geq 30 \end{aligned}$$

$$x_1, x_2, x_3 \geq 0 \tag{8.2}$$

Exercise 8.17*(Solution on p. 133.)*

$$\begin{aligned} \text{Minimize } z &= 40x_1 + 48x_2 + 30x_3 \\ \text{subject to } & 2x_1 + 2x_2 + x_3 \geq 25 \\ & x_1 + 3x_2 + 2x_3 \geq 30 \\ & x_1, x_2, x_3 \geq 0 \end{aligned}$$

Exercise 8.18*(Solution on p. 133.)*

A department store sells three different types of televisions: small, medium, and large. The store can sell up to 200 sets a month. The small, medium, and large televisions require, respectively, 3, 6, and 6 cubic feet of storage space, and a maximum of 1,020 cubic feet of storage space is available. The three types, small, medium, and large, take up, respectively, 2, 2, and 4 sales hours of labor, and a maximum of 600 hours of labor is available. If the profit made from each of these types is \$40, \$80, and \$100, respectively, how many of each type of television should be sold to maximize profit, and what is the maximum profit?

Exercise 8.19*(Solution on p. 133.)*

A factory manufactures three products, A, B, and C. Each product requires the use of two machines, Machine I and Machine II. The total hours available, respectively, on Machine I and Machine II per month are 180 and 300. The time requirements and profit per unit for each product are listed below.

	A	B	C
Machine I	1	2	2
Machine II	2	2	4
Profit	20	30	40

Table 8.1

How many units of each product should be manufactured to maximize profit, and what is the maximum profit?

Exercise 8.20*(Solution on p. 133.)*

A company produces three products, A, B, and C, at its two factories, Factory I and Factory II. Daily production of each factory for each product is listed below.

	Factory I	Factory II
Product A	10	20
Product B	20	20
Product C	20	10

Table 8.2

The company must produce at least 1000 units of product A, 1600 units of B, and 700 units of C. If the cost of operating Factory I is \$4,000 per day and the cost of operating Factory II is \$5000, how many days should each factory operate to complete the order at a minimum cost, and what is the minimum cost?

Exercise 8.21*(Solution on p. 133.)*

For his classes, Professor Wright gives three types of quizzes, objective, recall, and recall-plus. To keep his students on their toes, he has decided to give at least 20 quizzes next quarter. The three types, objective, recall, and recall-plus quizzes, require the students to spend, respectively, 10 minutes, 30 minutes, and 60 minutes for preparation, and Professor Wright would like them to spend at least 12 hours(720 minutes) preparing for these quizzes above and beyond the normal study time. An average score on an objective quiz is 5, on a recall type 6, and on a recall-plus 7, and Dr. Wright would like the students to score at least 130 points on all quizzes. It takes the professor one minute to grade an objective quiz, 2 minutes to grade a recall type quiz, and 3 minutes to grade a recall-plus quiz. How many of each type should he give in order to minimize his grading time?

Solutions to Exercises in Chapter 8

Solutions to Linear Programming: The Simplex Method: Homework

Solution to Exercise 8.1 (p. 129)

$$x_1 = 0, x_2 = 9, x_3 = 3, z = 27$$

Solution to Exercise 8.3 (p. 129)

Wheat 80 acres, corn 20 acres; Profit \$8400

Solution to Exercise 8.5 (p. 130)

600 boxes; 400 of Box I, 200 of Box II, and none of Box III

Solution to Exercise 8.6 (p. 130)

Initial Simplex Tableau

image needed!!!!

Solution to Exercise 8.8 (p. 130)

$$x_1 = 4, x_2 = 6, z = 34$$

Solution to Exercise 8.10 (p. 130)

$$x_1 = 4, x_2 = 8, y_1 = 0, y_2 = 0, z = 44$$

Solution to Exercise 8.11 (p. 130)

$$x_1 = 6, x_2 = 12, y_1 = 0, y_2 = 0, z = 126$$

Solution to Exercise 8.12 (p. 131)

$$x_1 = 6, x_2 = 4, x_3 = 0, y_1 = 0, y_2 = 0, z = 24$$

Solution to Exercise 8.13 (p. 131)

$$x_1 = 450, x_2 = 0, x_3 = 1800, y_1 = 750, y_2 = 0, y_3 = 0, z = 14,850$$

Solution to Exercise 8.14 (p. 131)

$$x_1 = 0, x_2 = 200, x_3 = 1600, y_1 = 0, y_2 = 0, y_3 = 1200, z = 9600$$

Solution to Exercise 8.15 (p. 131)

$$x_1 = 2, x_2 = 4, z = 64$$

Solution to Exercise 8.16 (p. 131)

$$x_1 = 10, x_2 = 10, x_3 = 0, z = 100$$

Solution to Exercise 8.17 (p. 131)

$$x_1 = 15/4, x_2 = 35/4, x_3 = 0, z = 570$$

Solution to Exercise 8.18 (p. 131)

$$x_1 = 0, x_2 = 40, x_3 = 130, y_1 = 30, y_2 = 0, y_3 = 0, z = 16,200$$

Solution to Exercise 8.19 (p. 132)

$$x_1 = 0, x_2 = 30, x_3 = 60, y_1 = 0, y_2 = 0, z = 3300$$

Solution to Exercise 8.20 (p. 132)

$$x_1 = 60, x_2 = 20, z = 340,000$$

Solution to Exercise 8.21 (p. 132)

$$x_1 = 12, x_2 = 0, x_3 = 10, z = 42$$

Chapter 9

Mathematics of Finance¹

9.1 Chapter Overview

In this chapter, you will learn to:

1. Solve financial problems that involve simple interest.
2. Solve problems involving compound interest.
3. Find the future value of an annuity, and the amount of payments to a sinking fund.
4. Find the present value of an annuity, and an installment payment on a loan.

9.2 Simple Interest and Discount

9.2.1 Section Overview

In this section, you will learn to:

1. Find simple interest.
2. Find present value.
3. Find discounts and proceeds.

SIMPLE INTEREST

It costs to borrow money. The rent one pays for the use of money is called the **interest**. The amount of money that is being borrowed or loaned is called the **principal** or **present value**. Simple interest is paid only on the original amount borrowed. When the money is loaned out, the person who borrows the money generally pays a fixed rate of interest on the principal for the time period he keeps the money. Although the interest rate is often specified for a year, it may be specified for a week, a month, or a quarter, etc. The credit card companies often list their charges as monthly rates, sometimes it is as high as 1.5% a month.

9.1: SIMPLE INTEREST

If an amount P is borrowed for a time t at an interest rate of r per time period, then the simple interest is given by

$$I = P \cdot r \cdot t$$

The total amount A also called the accumulated value or the future value is given by

$$A = P + I = P + Prt$$

$$\text{or } A = P(1 + rt)$$

Where interest rate r is expressed in decimals.

¹This content is available online at <<http://cnx.org/content/m18905/1.2/>>.

Example 9.1

Ursula borrows \$600 for 5 months at a simple interest rate of 15% per year. Find the interest, and the total amount she is obligated to pay?

Solution

The interest is computed by multiplying the principal with the interest rate and the time.

$$I = Prt \quad (9.1)$$

$$\begin{aligned} I &= \$6000 (.15) \frac{5}{12} \\ &= \$37.50 \end{aligned} \quad (9.2)$$

The total amount is

$$\begin{aligned} A &= \$600 + \$37.50 \\ &= \$637.50 \end{aligned} \quad (9.3)$$

Incidentally, the total amount can be computed directly as

$$\begin{aligned} A &= P(1, +, rt) \\ &= \$600 [1, +, (.15), (5, /, 12)] \\ &= \$600 (1, +, .0625) \\ &= \$637.50 \end{aligned} \quad (9.4)$$

Example 9.2

Jose deposited \$2500 in an account that pays 6% simple interest. How much money will he have at the end of 3 years?

Solution

The total amount or the future value is given by $A = P(1 + rt)$.

$$\begin{aligned} A &= \$2500 [1, +, (.06), (3)] \\ &= \$2950 \end{aligned} \quad (9.5)$$

Example 9.3

Darnel owes a total of \$3060 which includes 12% interest for the three years he borrowed the money. How much did he originally borrow?

Solution

This time we are asked to compute the principal P .

$$\begin{aligned} \$3060 &= P [1, +, (.12), (3)] \\ \$3060 &= P (1.36) \\ \frac{\$3060}{1.36} &= P \\ \$2250 &= P \end{aligned} \quad (9.6)$$

So Darnel originally borrowed \$2250.

Example 9.4

A Visa credit card company charges a 1.5% finance charge each month on the unpaid balance. If Martha owes \$2350 and has not paid her bill for three months, how much does she owe?

Solution

Before we attempt the problem, the reader should note that in this problem the rate of finance charge is given per month and not per year.

The total amount Martha owes is the previous unpaid balance plus the finance charge.

$$\begin{aligned} A &= \$2350 + \$2350(.015)(3) \\ &= \$2350 + \$105.75 \\ &= \$2455.75 \end{aligned} \tag{9.7}$$

Once again, we can compute the amount directly by using the formula $A = P(1 + rt)$

$$\begin{aligned} A &= \$2350 [1, +, (.015), (3)] \\ &= \$2350 (1.045) \\ &= \$2455.75 \end{aligned} \tag{9.8}$$

DISCOUNTS AND PROCEEDS

Banks often deduct the simple interest from the loan amount at the time that the loan is made. When this happens, we say the loan has been **discounted**. The interest that is deducted is called the **discount**, and the actual amount that is given to the borrower is called the **proceeds**. The amount the borrower is obligated to repay is called the **maturity value**.

9.2: DISCOUNT AND PROCEEDS

If an amount M is borrowed for a time t at a discount rate of r per year, then the discount D is

$$D = M \cdot r \cdot t$$

The proceeds P , the actual amount the borrower gets, is given by

$$P = M - D$$

$$P = M - Mrt$$

$$\text{or } P = M(1 - rt)$$

Where interest rate r is expressed in decimals.

Example 9.5

Francisco borrows \$1200 for 10 months at a simple interest rate of 15% per year. Determine the discount and the proceeds.

Solution

The discount D is the interest on the loan that the bank deducts from the loan amount.

$$D = Mrt \tag{9.9}$$

$$\begin{aligned} D &= \$1200 (.15) \left(\frac{10}{12}\right) \\ &= \$150 \end{aligned} \tag{9.10}$$

Therefore, the bank deducts \$150 from the maturity value of \$1200, and gives Francisco \$1050. Francisco is obligated to repay the bank \$1200.

In this case, the discount $D = \$150$, and the proceeds $P = \$1200 - \$150 = \$1050$.

Example 9.6

If Francisco wants to receive \$1200 for 10 months at a simple interest rate of 15% per year, what amount of loan should he apply for?

Solution

In this problem, we are given the proceeds P and are being asked to find the maturity value M .

We have $P = \$1200$, $r = .15$, $t = 10/12$. We need to find M .

We know

$$P = M - D \tag{9.11}$$

but

$$D = Mrt \tag{9.12}$$

therefore

$$P = M - Mrt \tag{9.13}$$

$$P = M(1 - rt) \tag{9.14}$$

$$\$1200 = M \left[1 - (.15) \left(\frac{10}{12} \right) \right]$$

$$\$1200 = M(1 - .125)$$

$$\$1200 = M(.875) \tag{9.15}$$

$$\frac{\$1200}{.875} = M$$

$$\$1371.43 = M$$

Therefore, Francisco should ask for a loan for \$1371.43.

The bank will discount \$171.43 and Francisco will receive \$1200.

9.3 Compound Interest

9.3.1 Section Overview

In this section you will learn to:

1. Find the future value of a lump-sum.
2. Find the present value of a lump-sum.
3. Find the effective interest rate.

In the Section 9.2 (Simple Interest and Discount), we did problems involving simple interest. Simple interest is charged when the lending period is short and often less than a year. When the money is loaned or borrowed for a longer time period, the interest is paid (or charged) not only on the principal, but also on the past interest, and we say the interest is **compounded**.

Suppose we deposit \$200 in an account that pays 8% interest. At the end of one year, we will have $\$200 + \$200(.08) = \$200(1 + .08) = \216 .

Now suppose we put this amount, \$216, in the same account. After another year, we will have $\$216 + \$216(.08) = \$216(1 + .08) = \233.28 .

So an initial deposit of \$200 has accumulated to \$233.28 in two years. Further note that had it been simple interest, this amount would have accumulated to only \$232. The reason the amount is slightly higher is because the interest (\$16) we earned the first year, was put back into the account. And this \$16 amount itself earned for one year an interest of $\$16(.08) = \1.28 , thus resulting in the increase. So we have earned interest on the principal as well as on the past interest, and that is why we call it compound interest.

Now suppose we leave this amount, \$233.28, in the bank for another year, the final amount will be $\$233.28 + \$233.28(.08) = \$233.28(1 + .08) = \251.94 .

Now let us look at the mathematical part of this problem so that we can devise an easier way to solve these problems.

After one year, we had

$$\$200(1 + .08) = \$216 \quad (9.16)$$

After two years, we had

$$\$216(1 + .08) \quad (9.17)$$

But $\$216 = \$200(1 + .08)$, therefore, the above expression becomes

$$\boxed{\$200(1 + .08)}(1 + .08) = \$233.28$$

After three years, we get

$$\boxed{\$200(1 + .08)(1 + .08)}(1 + .08) \quad (9.18)$$

Which can be written as

$$\$200(1 + .08)^3 = \$251.94 \quad (9.19)$$

Suppose we are asked to find the total amount at the end of 5 years, we will get

$$\$200(1 + .08)^5 = \$293.87 \quad (9.20)$$

We summarize as follows:

9.7

The original amount	$\$200 = \200
The amount after one year	$\$200(1 + .08) = \216
The amount after two years	$\$200(1 + .08)^2 = \233.28
The amount after three years	$\$200(1 + .08)^3 = \251.94
The amount after five years	$\$200(1 + .08)^5 = \293.87
The amount after t years	$\$200(1 + .08)^t$

Banks often compound interest more than one time a year. Consider a bank that pays 8% interest but compounds it four times a year, or quarterly. This means that every quarter the bank will pay an interest equal to one-fourth of 8%, or 2%.

Now if we deposit \$200 in the bank, after one quarter we will have $\$200\left(1 + \frac{.08}{4}\right)$ or \$204.

After two quarters, we will have $\$200(1 + \frac{.08}{4})^2$ or \$208.08.

After one year, we will have $\$200(1 + \frac{.08}{4})^4$ or \$216.49.

After three years, we will have $\$200(1 + \frac{.08}{4})^{12}$ or \$253.65, etc.

The original amount	$\$200 = \200	
The amount after one quarter	$\$200(1 + \frac{.08}{4}) = \204	
The amount after two quarters	$\$200(1 + \frac{.08}{4})^2 = \208.08	
The amount after one year	$\$200(1 + \frac{.08}{4})^4 = 216.49$	(9.21)
The amount after two years	$\$200(1 + \frac{.08}{4})^8 = \234.31	
The amount after three years	$\$200(1 + \frac{.08}{4})^{12} = \253.65	
The amount after five years	$\$200(1 + \frac{.08}{4})^{20} = \297.19	
The amount after t years	$\$200(1 + \frac{.08}{4})^{4t}$	

Therefore, if we invest a lump-sum amount of P dollars at an interest rate r , compounded n times a year, then after t years the final amount is given by

$$A = P(1 + \frac{r}{n})^{nt}$$

Example 9.8

If \$3500 is invested at 9% compounded monthly, what will the future value be in four years?

Solution

Clearly an interest of .09/12 is paid every month for four years. This means that the interest is compounded 48 times over the four-year period. We get

$$\$3500 \left(1 + \frac{.09}{12}\right)^{48} = \$5009.92 \quad (9.22)$$

Example 9.9

How much should be invested in an account paying 9% compounded daily for it to accumulate to \$5,000 in five years?

Solution

This time we know the future value, but we need to find the principal. Applying the formula $A = P(1 + \frac{r}{n})^{nt}$, we get

$$\begin{aligned} \$5000 &= P \left(1 + \frac{.09}{365}\right)^{365 \times 5} \\ \$5000 &= P (1.568225) \\ \$3188.32 &= P \end{aligned} \quad (9.23)$$

For comparison purposes, the government requires the bank to state their interest rate in terms of **effective yield or effective interest rate**.

For example, if one bank advertises its rate as 7.2% compounded monthly, and another bank advertises its rate as 7.5%, how are we to find out which is better? Let us look at the next example.

Example 9.10

If a bank pays 7.2% interest compounded monthly, what is the effective interest rate?

Solution

Suppose we deposit \$100 in this bank and leave it for a year, we will get

$$\$100 \left(1 + \frac{.072}{12} \right)^{12} = \$107.44 \quad (9.24)$$

Which means we earned an interest of $\$107.44 - \$100 = \$7.44$

But this interest is for \$100, therefore, the effective interest rate is 7.44%.

Interest can be compounded yearly, semiannually, quarterly, monthly, daily, hourly, minutely, and even every second. But what do we mean when we say the interest is compounded continuously, and how do we compute such amounts. When interest is compounded "infinitely many times", we say that the interest is **compounded continuously**. Our next objective is to derive a formula to solve such problems, and at the same time put things in proper perspective.

Suppose we put \$1 in an account that pays 100% interest. If the interest is compounded once a year, the total amount after one year will be $\$1(1 + 1) = \2 .

If the interest is compounded semiannually, in one year we will have $\$1(1 + 1/2)^2 = \2.25

If the interest is compounded quarterly, in one year we will have $\$1(1 + 1/4)^4 = \2.44 , etc.

We show the results as follows:

Frequency of compounding	Formula	Total amount
Annually	$\$1(1 + 1)$	\$2
Semiannually	$\$1(1 + 1/2)^2$	\$2.25
Quarterly	$\$1(1 + 1/4)^4$	\$2.44140625
Monthly	$\$1(1 + 1/12)^{12}$	\$2.61303529
Daily	$\$1(1 + 1/365)^{365}$	\$2.71456748
Hourly	$\$1(1 + 1/8760)^{8760}$	\$2.71812699
Every second	$\$1(1 + 1/525600)^{525600}$	\$2.71827922
Continuously	$\$1(2.718281828\dots)$	\$2.718281828...

Table 9.1

We have noticed that the \$1 we invested does not grow without bound. It starts to stabilize to an irrational number 2.718281828... given the name "e" after the great mathematician Euler.

In mathematics, we say that as n becomes infinitely large the expression $\left(1 + \frac{1}{n}\right)^n$ equals e .

Therefore, it is natural that the number e play a part in continuous compounding. It can be shown that as n becomes infinitely large the expression $\left(1 + \frac{r}{n}\right)^{nt} = e^{rt}$.

Therefore, it follows that if we invest $\$P$ at an interest rate r per year, compounded continuously, after t years the final amount will be given by $A = P \cdot e^{rt}$.

Example 9.11

If \$3500 is invested at 9% compounded continuously, what will the future value be in four years?

Solution

Using the formula for the continuous compounding, we get $A = Pe^{rt}$.

$$\begin{aligned} A &= \$3500e^{.09 \times 4} \\ &= \$3500e^{.36} \\ &= \$5016.65 \end{aligned} \tag{9.25}$$

Next we learn a common-sense rule to be able to readily estimate answers to some finance as well as real-life problems. We consider the following problem.

Example 9.12

If an amount is invested at 7% compounded continuously, what is the effective interest rate?

Solution

Once again, if we put \$1 in the bank at that rate for one year, and subtract that \$1 from the final amount, we will get the interest rate in decimals.

$$\begin{aligned} 1e^{.07} - 1 \\ 1.0725 - 1 \\ .0725 \quad \text{or} \quad 7.25 \end{aligned} \tag{9.26}$$

Example 9.13

If an amount is invested at 7%, estimate how long will it take to double.

Solution

Since we are estimating the answer, we really do not care how often the interest is compounded. Let us say the interest is compounded continuously. Then our problem becomes

$$Pe^{.07t} = 2P \tag{9.27}$$

We divide both sides by P

$$e^{.07t} = 2 \tag{9.28}$$

Now by substituting values by trial and error, we can estimate t to be about 10.

By doing a few similar calculations we can construct a table like the one below.

Annual interest rate	1%	2%	3%	4%	5%	6%	7%	8%	9%	10%
Number of years to double money	70	35	23	18	14	12	10	9	8	7

Table 9.2

The pattern in the table introduces us to the law of 70.

Definition 9.1: The Law of 70:

The number of years required to double money = $70 \div$ interest rate

It is a good idea to familiarize yourself with the law of 70, as it can help you to estimate many problems mentally.

Example 9.14

If the world population doubles every 35 years, what is the growth rate?

Solution

According to the law of 70,

$$\begin{aligned} 35 &= 70 \div r \\ r &= 2 \end{aligned} \tag{9.29}$$

Therefore, the world population grows at a rate of 2%.

We summarize the concepts learned in this chapter in the following table:

9.3: THE COMPOUND INTEREST

1. If an amount P is invested for t years at an interest rate r per year, compounded n times a year, then the future value is given by

$$A = P\left(1 + \frac{r}{n}\right)^{nt} \tag{9.30}$$

2. If a bank pays an interest rate r per year, compounded n times a year, then the effective interest rate is given by

$$r_e = 1\left(1 + \frac{r}{n}\right)^n - 1 \tag{9.31}$$

3. If an amount P is invested for t years at an interest rate r per year, compounded continuously, then the future value is given by

$$A = Pe^{rt} \tag{9.32}$$

4. The law of 70 states that

The number of years to double money = $70 \div$ interest rate

9.4 Annuities and Sinking Funds

9.4.1 Section Overview

In this section, you will learn to:

1. Find the future value of an annuity.
2. Find the amount of payments to a sinking fund.

In Section 9.2 (Simple Interest and Discount) and Section 9.3 (Compound Interest), we did problems where an amount of money was deposited lump sum in an account and was left there for the entire time period. Now we will do problems where timely payments are made in an account. When a sequence of payments of some fixed amount are made in an account at equal intervals of time, we call that an **annuity**. And this is the subject of this section.

To develop a formula to find the value of an annuity, we will need to recall the formula for the sum of a geometric series.

A geometric series is of the form: $a + ar + ar^2 + ar^3 + \dots + ar^n$.

The following are some examples of geometric series.

$$3 + 6 + 12 + 24 + 48 \quad (9.33)$$

$$2 + 6 + 18 + 54 + 162 \quad (9.34)$$

$$37 + 3.7 + .37 + .037 + .0037 \quad (9.35)$$

In a geometric series, each subsequent term is obtained by multiplying the preceding term by a number, called the common ratio. And a geometric series is completely determined by knowing its first term, the common ratio, and the number of terms.

In the example, $a + ar + ar^2 + ar^3 + \dots + ar^{n-1}$ the first term of the series is a , the common ratio is r , and the number of terms are n .

In your algebra class, you developed a formula for finding the sum of a geometric series. The formula states that the sum of a geometric series is

$$\frac{a[r^n - 1]}{r - 1} \quad (9.36)$$

We will use this formula to find the value of an annuity.

Consider the following example.

Example 9.15

If at the end of each month a deposit of \$500 is made in an account that pays 8% compounded monthly, what will the final amount be after five years?

Solution

There are 60 deposits made in this account. The first payment stays in the account for 59 months, the second payment for 58 months, the third for 57 months, and so on.

The first payment of \$500 will accumulate to an amount of $\$500(1 + .08/12)^{59}$.

The second payment of \$500 will accumulate to an amount of $\$500(1 + .08/12)^{58}$.

The third payment will accumulate to $\$500(1 + .08/12)^{57}$.

And so on.

The last payment is taken out the same time it is made, and will not earn any interest.

To find the total amount in five years, we need to add the accumulated value of these sixty payments.

In other words, we need to find the sum of the following series.

$$\$500(1 + .08/12)^{59} + \$500(1 + .08/12)^{58} + \$500(1 + .08/12)^{57} + \dots + \$500 \quad (9.37)$$

Written backwards, we have

$$\$500 + \$500(1 + .08/12) + \$500(1 + .08/12)^2 + \dots + \$500(1 + .08/12)^{59} \quad (9.38)$$

This is a geometric series with $a = 500$, $r = (1 + .08/12)$, and $n = 59$. Therefore the sum is

$$\begin{aligned} & \frac{\$500[(1+.08/12)^{60}-1]}{.08/12} \\ &= \$500 (73.47686) \\ &= \$36738.43 \end{aligned} \tag{9.39}$$

When the payments are made at the end of each period rather than at the beginning, we call it an **ordinary annuity**.

9.4: Future Value of an Ordinary Annuity

If a payment of m dollars is made in an account n times a year at an interest r , then the final amount A after t years is

$$A = \frac{m \left[(1 + r/n)^{nt} - 1 \right]}{r/n} \tag{9.40}$$

Example 9.16

Tanya deposits \$300 at the end of each quarter in her savings account. If the account earns 5.75%, how much money will she have in 4 years?

Solution

The future value of this annuity can be found using the above formula.

$$\begin{aligned} &= \frac{\$300[(1+.0575/4)^{16}-1]}{.0575/4} \\ &= \$300 (17.8463) \\ &= \$5353.89 \end{aligned} \tag{9.41}$$

Example 9.17

Robert needs \$5000 in three years. How much should he deposit each month in an account that pays 8% in order to achieve his goal?

Solution

If Robert saves x dollars per month, after three years he will have

$$\frac{x \left[(1 + .08/12)^{36} - 1 \right]}{.08/12} \tag{9.42}$$

But we'd like this amount to be \$5,000. Therefore,

$$\begin{aligned} \frac{x[(1+.08/12)^{36}-1]}{.08/12} &= \$5000 \\ x(40.5356) &= \$5000 \\ x &= \frac{5000}{40.5356} \\ x &= \$123.35 \end{aligned} \tag{9.43}$$

Example 9.18

A business needs \$450,000 in five years. How much should be deposited each quarter in a sinking fund that earns 9% to have this amount in five years?

Solution

Again, suppose that x dollars are deposited each quarter in the sinking fund. After five years, the future value of the fund should be \$450,000. Which suggests the following relationship:

$$\begin{aligned} \frac{x[(1+.09/4)^{20}-1]}{.09/4} &= \$450,000 \\ x(24.9115) &= 450,000 \\ x &= \frac{450000}{24.9115} \\ x &= 18,063.93 \end{aligned} \tag{9.44}$$

If the payment is made at the beginning of each period, rather than at the end, we call it an annuity due. The formula for the annuity due can be derived in a similar manner. Reconsider Example 9.15, with the change that the deposits be made at the beginning of each month.

Example 9.19

If at the beginning of each month a deposit of \$500 is made in an account that pays 8% compounded monthly, what will the final amount be after five years?

Solution

There are 60 deposits made in this account. The first payment stays in the account for 60 months, the second payment for 59 months, the third for 58 months, and so on.

The first payment of \$500 will accumulate to an amount of $\$500(1 + .08/12)^{60}$.

The second payment of \$500 will accumulate to an amount of $\$500(1 + .08/12)^{59}$.

The third payment will accumulate to $\$500(1 + .08/12)^{58}$.

And so on.

The last payment is in the account for a month and accumulates to $\$500(1 + .08/12)$

To find the total amount in five years, we need to find the sum of the following series.

$$\$500(1 + .08/12)^{60} + \$500(1 + .08/12)^{59} + \$500(1 + .08/12)^{58} + \dots + \$500(1 + .08/12) \tag{9.45}$$

Written backwards, we have

$$\$500(1 + .08/12) + \$500(1 + .08/12)^2 + \dots + \$500(1 + .08/12)^{60} \tag{9.46}$$

If we add \$500 to this series, and later subtract that \$500, the value will not change. We get

$$\$500 + \$500(1 + .08/12) + \$500(1 + .08/12)^2 + \dots + \$500(1 + .08/12)^{60} - \$500 \tag{9.47}$$

Not considering the last term, we have a geometric series with $a = \$500$, $r = (1 + .08/12)$, and $n = 60$. Therefore the sum is

$$\begin{aligned}
 & \frac{\$500[(1+.08/12)^{61}-1]}{.08/12} - \$500 \\
 &= \$500(74.9667) - \$500 \\
 &= \$37483.35 - \$500 \\
 &= \$36983.35
 \end{aligned}
 \tag{9.48}$$

So, in the case of an annuity due, to find the future value, we increase the number of periods n by 1, and subtract one payment.

$$\text{The Future Value of an Annuity due} = \frac{m[(1+r/n)^{nt+1}-1]}{r/n} - m$$

Most of the problems we are going to do in this chapter involve ordinary annuity, therefore, we will down play the significance of the last formula. We mentioned the last formula only for completeness.

Finally, it is the author's wish that the student learn the concepts in a way that he or she will not have to memorize every formula. It is for this reason formulas are kept at a minimum. But before we conclude this section we will once again mention one single equation that will help us find the future value, as well as the sinking fund payment.

9.5: The Equation to Find the Future Value of an Ordinary Annuity, Or the Amount of Periodic Payment to a Sinking Fund

If a payment of m dollars is made in an account n times a year at an interest r , then the future value A after t years is

$$A = \frac{m[(1+r/n)^{nt}-1]}{r/n}$$

9.5 Present Value of an Annuity and Installment Payment

9.5.1 Section Overview

In this section, you will learn to:

1. Find the present value of an annuity.
2. Find the amount of installment payment on a loan.

In Section 9.3 (Compound Interest), we learned to find the future value of a lump sum, and in Section 9.4 (Annuities and Sinking Funds), we learned to find the future value of an annuity. With these two concepts in hand, we will now learn to amortize a loan, and to find the present value of an annuity.

Let us consider the following problem.

Example 9.20

Suppose you have won a lottery that pays \$1,000 per month for the next 20 years. But, you prefer to have the entire amount now. If the interest rate is 8%, how much will you accept?

Solution

This classic present value problem needs our complete attention because the rationalization we use to solve this problem will be used again in the problems to follow.

Consider for argument purposes that two people Mr. Cash, and Mr. Credit have won the same lottery of \$1,000 per month for the next 20 years. Now, Mr. Credit is happy with his \$1,000 monthly payment, but Mr. Cash wants to have the entire amount now. Our job is to determine

how much Mr. Cash should get. We reason as follows: If Mr. Cash accepts x dollars, then the x dollars deposited at 8% for 20 years should yield the same amount as the \$1,000 monthly payments for 20 years. In other words, we are comparing the future values for both Mr. Cash and Mr. Credit, and we would like the future values to equal.

Since Mr. Cash is receiving a lump sum of x dollars, its future value is given by the lump sum formula we studied in Section 9.3 (Compound Interest), and it is

$$x(1 + .08/12)^{240} \tag{9.49}$$

Since Mr. Credit is receiving a sequence of payments, or an annuity, of \$1,000 per month, its future value is given by the annuity formula we learned in Section 9.4 (Annuities and Sinking Funds). This value is

$$\frac{\$1000 \left[(1 + .08/12)^{240} - 1 \right]}{.08/12} \tag{9.50}$$

The only way Mr. Cash will agree to the amount he receives is if these two future values are equal. So we set them equal and solve for the unknown.

$$\begin{aligned} x(1 + .08/12)^{240} &= \frac{\$1000[(1+.08/12)^{240}-1]}{.08/12} \\ x(4.9268) &= \$1000(589.02041) \\ x(4.9268) &= \$589020.41 \\ x &= \$119,554.36 \end{aligned} \tag{9.51}$$

The reader should also note that if Mr. Cash takes his lump sum of \$119,554.36 and invests it at 8% compounded monthly, he will have \$589,020.41 in 20 years.

We have just found the present value of an annuity of \$1,000 each month for 20 years at 8%.

We now consider another problem that involves the same logic.

Example 9.21

Find the monthly payment for a car costing \$15,000 if the loan is amortized over five years at an interest rate of 9%.

Solution

Again, consider the following scenario:

Two people, Mr. Cash and Mr. Credit, go to buy the same car that costs \$15,000. Mr. Cash pays cash and drives away, but Mr. Credit wants to make monthly payments for five years. Our job is to determine the amount of the monthly payment. We reason as follows: If Mr. Credit pays x dollars per month, then the x dollar payment deposited each month at 9% for 5 years should yield the same amount as the \$15,000 lump sum deposited for 5 years. Again, we are comparing the future values for both Mr. Cash and Mr. Credit, and we would like them to be the same.

Since Mr. Cash is paying a lump sum of \$15,000, its future value is given by the lump sum formula, and it is

$$\$15,000(1 + .09/12)^{60} \tag{9.52}$$

Mr. Credit wishes to make a sequence of payments, or an annuity, of x dollars per month, and its future value is given by the annuity formula, and this value is

$$\frac{x \left[(1 + .09/12)^{60} - 1 \right]}{.09/12} \quad (9.53)$$

We set the two future amounts equal and solve for the unknown.

$$\begin{aligned} \$15,000(1 + .09/12)^{60} &= \frac{x[(1+.09/12)^{60}-1]}{.09/12} \\ \$15,000(1.5657) &= x(75.4241) \\ \$311.38 &= x \end{aligned} \quad (9.54)$$

Therefore, the monthly payment on the loan is \$311.38 for five years.

9.6: The Equation to Find the Present Value of an Annuity, Or the Installment Payment for a Loan

If a payment of m dollars is made in an account n times a year at an interest r , then the present value P of the annuity after t years is

$$P(1 + r/n)^{nt} = \frac{m[(1+r/n)^{nt}-1]}{r/n}$$

where the amount P is also the loan amount, and m the periodic payment.

9.6 Miscellaneous Application Problems

We have already developed the tools to solve most finance problems. Now we use these tools to solve some application problems.

One of the most common problems deals with finding the balance owed at a given time during the life of a loan. Suppose a person buys a house and amortizes the loan over 30 years, but decides to sell the house a few years later. At the time of the sale, he is obligated to pay off his lender, therefore, he needs to know the balance he owes. Since most long term loans are paid off prematurely, we are often confronted with this problem. Let us consider an example.

Example 9.22

Mr. Jackson bought his house in 1975, and financed the loan for 30 years at an interest rate of 9.8%. His monthly payment was \$1260. In 1995, Mr. Jackson decided to pay off the loan. Find the balance of the loan he still owes.

Solution

The reader should note that the original amount of the loan is not mentioned in the problem. That is because we don't need to know that to find the balance.

As for the bank or lender is concerned, Mr. Jackson is obligated to pay \$1260 each month for 10 more years. But since Mr. Jackson wants to pay it all off now, we need to find the present value of the \$1260 payments. Using the formula we get,

$$\begin{aligned} x(1 + .098/12)^{120} &= \frac{\$1260[(1+.098/12)^{120}-1]}{.098/12} \\ x(2.6539) &= \$255168.94 \\ x &= \$96,149.65 \end{aligned} \quad (9.55)$$

The next application we discuss deals with bond problems. Whenever a business, and for that matter the U. S. government, needs to raise money it does it by selling bonds. A **bond** is a

certificate of promise that states the terms of the agreement. Usually the businesses sells bonds for the face amount of \$1,000 each for a period of 10 years. The person who buys the bond, the **bondholder**, pays \$1,000 to buy the bond. The bondholder is promised two things: First that he will get his \$1,000 back in ten years, and second that he will receive a fixed amount of interest every six months. As the market interest rates change, the price of the bond starts to fluctuate. The bonds are bought and sold in the market at their **fair market value**. The interest rate a bond pays is fixed, but if the market interest rate goes up, the value of the bond drops since the money invested in the bond can earn more elsewhere. When the value of the bond drops, we say it is trading at a **discount**. On the other hand, if the market interest rate drops, the value of the bond goes up, and it is trading at a **premium**.

Example 9.23

The Orange computer company needs to raise money to expand. It issues a 10-year \$1,000 bond that pays \$30 every six months. If the current market interest rate is 7%, what is the fair market value of the bond?

Solution

A bond certificate promises us two things – An amount of \$1,000 to be paid in 10 years, and a semi-annual payment of \$30 for ten years. Therefore, to find the fair market value of the bond, we need to find the present value of the lump sum of \$1,000 we are to receive in 10 years, as well as, the present value of the \$30 semi-annual payments for the 10 years.

The present value of the lump-sum \$1,000 is

$$x(1 + .07/2)^{20} = \$1,000 \quad (9.56)$$

Note that since the interest is paid twice a year, the interest is compounded twice a year.

$$\begin{aligned} x(1.9898) &= \$1,000 \\ x &= \$502.57 \end{aligned} \quad (9.57)$$

The present value of the \$30 semi-annual payments is

$$\begin{aligned} x \left(1 + .07/2^{20} = \frac{\$30[(1+.07/2)^{20}-1]}{.07/2} \right) \\ x = \$426.37 \end{aligned} \quad (9.58)$$

Once again,

The present value of the lump-sum \$1,000 = \$502.57

The present value of the \$30 semi-annual payments = \$426.37

Therefore, the fair market value of the bond is \$502.57 + \$426.37 = \$928.94

Example 9.24

An amount of \$500 is borrowed for 6 months at a rate of 12%. Make an amortization schedule showing the monthly payment, the monthly interest on the outstanding balance, the portion of the payment contributing toward reducing the debt, and the outstanding balance.

Solution

The reader can verify that the monthly payment is \$86.27.

The first month, the outstanding balance is \$500, and therefore, the monthly interest on the outstanding balance is

$$(\text{outstanding balance})(\text{the monthly interest rate}) = (\$500)(.12/12) = \$5 \quad (9.59)$$

This means, the first month, out of the \$86.27 payment, \$5 goes toward the interest and the remaining \$81.27 toward the balance leaving a new balance of $\$500 - \$81.27 = \$418.73$.

Similarly, the second month, the outstanding balance is \$418.73, and the monthly interest on the outstanding balance is $(\$418.73)(.12/12) = \4.19 . Again, out of the \$86.27 payment, \$4.19 goes toward the interest and the remaining \$82.08 toward the balance leaving a new balance of $\$418.73 - \$82.08 = \$336.65$. The process continues in the table below.

Payment #	Payment	Interest	Debt Payment	Balance
1	\$86.27	\$5	\$81.27	\$418.73
2	\$86.27	\$4.19	\$82.08	\$336.65
3	\$86.27	\$3.37	\$82.90	\$253.75
4	\$86.27	\$2.54	\$83.73	\$170.02
5	\$86.27	\$1.70	\$84.57	\$85.45
6	\$86.27	\$0.85	\$85.42	\$0.03

Table 9.3

Note that the last balance of 3 cents is due to error in rounding off.

Most of the other applications in this section's problem set are reasonably straight forward, and can be solved by taking a little extra care in interpreting them. And remember, there is often more than one way to solve a problem.

9.7 Classification of Finance Problems

We'd like to remind the reader that the hardest part of solving a finance problem is determining the category it falls into. So in this section, we will emphasize the classification of problems rather than finding the actual solution.

We suggest that the student read each problem carefully and look for the word or words that may give clues to the kind of problem that is presented. For instance, students often fail to distinguish a lump-sum problem from an annuity. Since the payments are made each period, an annuity problem contains words such as each, every, per etc.. One should also be aware that in the case of a lump-sum, only a single deposit is made, while in an annuity numerous deposits are made at equal spaced time intervals.

Students often confuse the present value with the future value. For example, if a car costs \$15,000, then this is its present value. Surely, you cannot convince the dealer to accept \$15,000 in some future time, say, in five years. Recall how we found the installment payment for that car. We assumed that two people, Mr. Cash and Mr. Credit, were buying two identical cars both costing \$15,000 each. To settle the argument that both people should pay exactly the same amount, we put Mr. Cash's cash of \$15,000 in the bank as a lump-sum and Mr. Credit's monthly payments of x dollars each as an annuity. Then we make sure that the future values of these two accounts are equal. As you remember, at an interest rate of 9%

the future value of Mr. Cash's lump-sum was $\$15,000(1 + .09/12)^{60}$, and

the future value of Mr. Credit's annuity was $\frac{x[(1+.09/12)^{60}-1]}{.09/12}$.

To solve the problem, we set the two expressions equal and solve for x .

The present value of an annuity is found in exactly the same way. For example, suppose Mr. Credit is told that he can buy a particular car for \$311.38 a month for five years, and Mr. Cash wants to know how much he needs to pay. We are finding the present value of the annuity of \$311.38 per month, which is the same as finding the price of the car. This time our unknown quantity is the price of the car. Now suppose the price of the car is y , then

the future value of Mr. Cash's lump-sum is $y(1 + .09/12)^{60}$, and

the future value of Mr. Credit's annuity is $\frac{\$311.38[(1+.09/12)^{60}-1]}{.09/12}$.

Setting them equal we get,

$$\begin{aligned} y(1 + .09/12)^{60} &= \frac{\$311.38[(1+.09/12)^{60}-1]}{.09/12} \\ y(1.5657) &= (\$311.38)(75.4241) \\ y(1.5657) &= \$23,485.57 \\ y &= \$15,000.04 \end{aligned} \tag{9.60}$$

We now list six problems that form a basis for all finance problems. Further, we classify these problems and give an equation for the solution.

9.7: Classification of Problems and Equations for Solutions

Problem 1

If \$2,000 is invested at 7% compounded quarterly, what will the final amount be in 5 years?

Solution

Classification: Future Value of a Lump-sum or FV of a lump-sum.

Equation: $FV = \$2000(1 + .07/4)^{20}$.

Problem 2

How much should be invested at 8% compounded yearly, for the final amount to be \$5,000 in five years?

Solution

Classification: Present Value of a Lump-sum or PV of a lump-sum.

Equation: $PV(1 + .08)^5 = \$5,000$

Problem 3

If \$200 is invested each month at 8.5% compounded monthly, what will the final amount be in 4 years?

Solution

Classification: Future Value of an Annuity or FV of an annuity.

Equation: $FV = \frac{\$200[(1+.085/12)^{48}-1]}{.085/12}$

Problem 4

How much should be invested each month at 9% for it to accumulate to \$8,000 in three years?

Solution

Classification: Sinking Fund Payment

Equation: $\frac{m[(1+.09/12)^{36}-1]}{.09/12} = \$8,000$

Problem 5

Keith has won a lottery paying him \$2,000 *per* month for the next 10 years. He'd rather have the entire sum now. If the interest rate is 7.6%, how much should he receive?

Solution

Classification: Present Value of an Annuity or PV of an annuity.

$$\text{Equation: } PV(1 + .076/12)^{120} = \frac{\$2000[(1 + .076/12)^{120} - 1]}{.076/12}$$

Problem 6

Mr. A has just donated \$25,000 to his alma mater. Mr. B would like to donate an equivalent amount, but would like to pay by monthly payments over a five year period. If the interest rate is 8.2%, determine the size of the monthly payment?

Solution

Classification: Installment Payment.

$$\text{Equation: } \frac{m[(1 + .082/12)^{60} - 1]}{.082/12} = \$25,000(1 + .082/12)^{60}.$$

Chapter 10

Mathematics of Finance: Homework¹

10.1 SIMPLE INTEREST AND DISCOUNT

Do the following simple interest problems.

Exercise 10.1

(Solution on p. 165.)

If an amount of \$2,000 is borrowed at a simple interest rate of 10% for 3 years, how much is the interest?

Exercise 10.2

You borrow \$4,500 for six months at a simple interest rate of 8%. How much is the interest?

Exercise 10.3

(Solution on p. 165.)

John borrows \$2400 for 3 years at 9% simple interest. How much will he owe at the end of 3 years?

Exercise 10.4

Jessica takes a loan of \$800 for 4 months at 12% simple interest. How much does she owe at the end of the 4-month period?

Exercise 10.5

(Solution on p. 165.)

If an amount of \$2,160, which includes a 10% simple interest for 2 years, is paid back, how much was borrowed 2 years earlier?

Exercise 10.6

Jamie just paid off a loan of \$2,544, the principal and simple interest. If he took out the loan six months ago at 12% simple interest, what was the amount borrowed?

Exercise 10.7

(Solution on p. 165.)

Shanti charged \$800 on her charge card and did not make a payment for six months. If there is a monthly charge of 1.5%, how much does she owe?

Exercise 10.8

A credit card company charges 18% interest on the unpaid balance. If you owed \$2000 three months ago and have been delinquent since, how much do you owe?

Exercise 10.9

(Solution on p. 165.)

An amount of \$2000 is borrowed for 3 years. At the end of the three years, \$2660 is paid back. What was the simple interest rate?

Exercise 10.10

Nancy borrowed \$1,800 and paid back \$1,920, four months later. What was the simple interest rate?

¹This content is available online at <<http://cnx.org/content/m38651/1.1/>>.

Exercise 10.11*(Solution on p. 165.)*

Jose agrees to pay \$2,000 in one year at an interest rate of 12%. The bank subtracts the discount of 12% of \$2,000, and gives the rest to Jose. Find the amount of the discount and the proceeds to Jose.

Exercise 10.12

Tasha signs a note for a discounted loan agreeing to pay \$1200 in 8 months at an 18% discount rate. Determine the amount of the discount and the proceeds to her.

Exercise 10.13*(Solution on p. 165.)*

An amount of \$8,000 is borrowed at a discount rate of 12%, find the proceeds if the length of the loan is 7 months.

Exercise 10.14

An amount of \$4,000 is borrowed at a discount rate of 10%, find the proceeds if the length of the loan is 180 days.

Exercise 10.15*(Solution on p. 165.)*

Derek needs \$2400 new equipment for his shop. He can borrow this money at a discount rate of 14% for a year. Find the amount of the loan he should ask for so that his proceeds are \$2400.

Exercise 10.16

Mary owes June \$750, and wants to pay her off. She decides to borrow the amount from her bank at a discount rate of 16%. If she borrows the money for 10 months, find the amount of the loan she should ask for so that her proceeds are \$750?

10.2 COMPOUND INTEREST

Do the following compound interest problems involving a lump-sum amount.

Exercise 10.17*(Solution on p. 165.)*

If \$8,000 is invested at 9.2% compounded monthly, what will the final amount be in 4 years?

Exercise 10.18

How much should be invested at 10.3% for it to amount to \$10,000 in 6 years?

Exercise 10.19*(Solution on p. 165.)*

Lydia's aunt Rose left her \$5,000. Lydia spent \$1,000 on her wardrobe and deposited the rest in an account that pays 6.9% compounded daily. How much money will she have in 5 years?

Exercise 10.20

Thuy needs \$1,850 in eight months for her college tuition. How much money should she deposit lump sum in an account paying 8.2% compounded monthly to achieve that goal?

Exercise 10.21*(Solution on p. 165.)*

Bank A pays 5% compounded daily, while Bank B pays 5.12% compounded monthly. Which bank pays more? Explain.

Exercise 10.22

EZ Photo Company needs five copying machines in $2\frac{1}{2}$ years for a total cost of \$15,000. How much money should be deposited now to pay for these machines, if the interest rate is 8% compounded semiannually?

Exercise 10.23*(Solution on p. 165.)*

Jon's grandfather was planning to give him \$12,000 in 10 years. Jon has convinced his grandfather to pay him \$6,000 now, instead. If Jon invests this \$6,000 at 7.5% compounded continuously, how much money will he have in 10 years?

Exercise 10.24

What will be the price of a \$20,000 car in 5 years if the inflation rate is 6%?

Exercise 10.25 **(Solution on p. 165.)**

At an interest rate of 8% compounded continuously, how many years will it take to double your money? Hint: You may do this on your calculator by trial and error.

Exercise 10.26

If an investment earns 10% compounded continuously, in how many years will it triple? Hint: You may do this on your calculator by trial and error.

Exercise 10.27 **(Solution on p. 165.)**

The City Library has ordered a new computer system costing \$158,000. The system will be delivered in 6 months, and the full amount will be due 30 days after delivery. How much should be deposited today into an account paying 7.5% compounded monthly to have \$158,000 in 7 months?

Exercise 10.28

Mr. and Mrs. Tran are expecting a baby girl in a few days. They want to put away money for her college education now. How much money should they deposit in an account paying 10.2% so they will have \$100,000 in 18 years to pay for their daughter's educational expenses?

Exercise 10.29 **(Solution on p. 165.)**

Find the effective interest rate for an account paying 7.2% compounded quarterly.

Exercise 10.30

If a bank pays 5.75% compounded monthly, what is the effective interest rate?

Exercise 10.31 **(Solution on p. 165.)**

Population of California in the year 1995 was 32 million. If the population grows at a rate of 2%, what will the population be in 2025?

Exercise 10.32

According to the Law of 70, if an amount grows at an annual rate of 1%, then it doubles every seventy years. Suppose a bank pays 5% interest, how long will it take for you to double your money? How about at 15%?

10.3 ANNUITIES AND SINKING FUNDS

Each of the following problems involve an annuity - a sequence of payments.

Exercise 10.33 **(Solution on p. 165.)**

Find the future value of an annuity of \$200 per month for 5 years at 6% compounded monthly.

Exercise 10.34

How much money should be deposited at the end of each month in an account paying 7.5% for it to amount to \$10,000 in 5 years?

Exercise 10.35 **(Solution on p. 165.)**

At the end of each month Rita deposits \$300 in an account that pays 5%. What will the final amount be in 4 years?

Exercise 10.36

Mr. Chang wants to retire in 10 years and can save \$650 every three months. If the interest rate is 7.8%, how much will he have at the end of 5 years?

Exercise 10.37 **(Solution on p. 165.)**

A firm needs to replace most of its machinery in five years at a cost of \$500,000. The company wishes to create a sinking fund to have this money available in five years. How much should the quarterly deposits be if the fund earns 8%?

Exercise 10.38

Mrs. Brown needs \$5,000 in three years. If the interest rate is 9%, how much should she save at the end of each month to have that amount in three years?

Exercise 10.39*(Solution on p. 165.)*

A company has a \$120,000 note due in 4 years. How much should be deposited at the end of each quarter in a sinking fund to payoff the note in four years if the interest rate is 8%?

Exercise 10.40

You are now 20 years of age and decide to save \$100 at the end of each month until you are 65. If the interest rate is 9.2%, how much money will you have when you are 65?

Exercise 10.41*(Solution on p. 165.)*

Is it better to receive \$400 at the beginning of each month for six years, or a lump sum of \$25,000 today if the interest rate is 7%? Explain.

Exercise 10.42

In order to save money for a new computer Jill decided to save \$125 at the beginning of each month for the next 8 months. If the interest rate is 7%, how much money will she have at the end of 8 months?

Exercise 10.43*(Solution on p. 165.)*

Mrs. Gill puts \$2200 at the end of each year in her IRA account that earns 9% per year. How much total money will she have in this account after 20 years?

Exercise 10.44

If the inflation rate stays at 6% per year for the next five years, how much will the price be of a \$15,000 car in five years? How much must you save at the end of each month at an interest rate of 7.3% to buy that car in 5 years?

10.4 PRESENT VALUE OF AN ANNUITY AND INSTALLMENT PAYMENT

For the following problems, show all work.

Exercise 10.45*(Solution on p. 165.)*

Shawn has won a lottery paying him \$10,000 per month for the next 20 years. He'd rather have the whole amount in one lump sum today. If the current interest rate is 8.2%, how much money can he hope to get?

Exercise 10.46

Sonya bought a car for \$15,000. Find the monthly payment if the loan is to be amortized over 5 years at a rate of 10.1%.

Exercise 10.47*(Solution on p. 165.)*

You determine that you can afford \$250 per month for a car. What is the maximum amount you can afford to pay for a car if the interest rate is 9% and you want to repay the loan in 5 years?

Exercise 10.48

Compute the monthly payment for a house loan of \$200,000 to be financed over 30 years at an interest rate of 10%.

Exercise 10.49*(Solution on p. 165.)*

If the \$200,000 loan in the previous problem is financed over 15 years rather than 30 years at 10%, what will the monthly payment be?

Exercise 10.50

Friendly Auto offers Jennifer a car for \$2000 down and \$300 per month for 5 years. Jason wants to buy the same car but wants to pay cash. How much must Jason pay if the interest rate is 9.4%?

Exercise 10.51*(Solution on p. 166.)*

The Gomez family bought a house for \$175,000. They paid 20% down and amortized the rest at 11.2% over a 30-year period. Find their monthly payment.

Exercise 10.52

Mr. and Mrs. Wong purchased their new house for \$350,000. They made a down payment of 15%, and amortized the rest over 30 years. If the interest rate is 9%, find their monthly payment.

Exercise 10.53*(Solution on p. 166.)*

A firm needs a piece of machinery that has a useful life of 5 years. It has an option of leasing it for \$10,000 a year, or buying it for \$40,000 cash. If the interest rate is 10%, which choice is better?

Exercise 10.54

Jackie wants to buy a \$19,000 car, but she can afford to pay only \$300 per month for 5 years. If the interest rate is 6%, how much does she need to put down?

Exercise 10.55*(Solution on p. 166.)*

Vijay's tuition at Stanford for the next year is \$32,000. His parents have decided to pay the tuition by making nine monthly payments. If the interest rate is 9%, what is the monthly payment?

Exercise 10.56

Glen borrowed \$10,000 for his college education at 8% compounded quarterly. Three years later, after graduating and finding a job, he decided to start paying off his loan. If the loan is amortized over five years at 9%, find his monthly payment for the next five years.

10.5 MISCELLANEOUS APPLICATION PROBLEMS

For the following four problems, assume a \$200,000 house loan is amortized over 30 years at an interest rate of 10.4%.

Exercise 10.57*(Solution on p. 166.)*

Find the monthly payment.

Exercise 10.58

Find the balance owed after 20 years.

Exercise 10.59*(Solution on p. 166.)*

Find the balance of the loan after 100 payments.

Exercise 10.60

Find the monthly payment if the original loan were amortized over 15 years.

Exercise 10.61*(Solution on p. 166.)*

Mr. Patel wants to pay off his car loan. The monthly payment for his car is \$365, and he has 16 payments left. If the loan was financed at 9%, how much does he owe?

Exercise 10.62

An amount of \$2000 is borrowed for a year at a rate of 18%. Make an amortization schedule showing the monthly payment, the monthly interest on the outstanding balance, the portion of the payment going toward reducing the debt, and the balance.

Exercise 10.63*(Solution on p. 166.)*

Fourteen months after Dan bought his new car he lost his job. His car was repossessed by his lender after he had made only 14 monthly payments of \$376 each. If the loan was financed over a 4-year period at an interest rate of 10.3%, how much did the car cost the lender? In other words, how much did Dan still owe on the car?

Exercise 10.64

You have a choice of either receiving \$5,000 at the end of each year for the next 5 years or receiving \$3000 per year for the next 10 years. If the current interest rate is 9%, which is better?

Exercise 10.65*(Solution on p. 166.)*

Mr. Smith is planning to retire in 25 years and would like to have \$250,000 then. What monthly payment made at the end of each month to an account that pays 6.5% will achieve his objective?

Exercise 10.66

Assume Mr. Smith has reached retirement and has \$250,000 in an account which is earning 6.5%. He would now like to make equal monthly withdrawals for the next 15 years to completely deplete this account. Find the withdrawal payment.

Exercise 10.67*(Solution on p. 166.)*

A ten-year \$1,000 bond pays \$35 every six months. If the current interest rate is 8.2%, find the fair market value of the bond.

Hint: You must do the following.

- Find the present value of \$1000.
- Find the present value of the \$35 payments.
- The fair market value of the bond = $a + b$

Exercise 10.68

Find the fair market value of the ten-year \$1,000 bond that pays \$35 every six months, if the current interest rate has dropped to 6%.

Hint: Again, you must do the following.

- Find the present value of \$1000.
- Find the present value of the \$35 payments.
- The fair market value of the bond = $a + b$

10.6 CLASSIFICATION OF FINANCE PROBLEMS

Let the letters A , B , C , D , E and F be represented as follows:

A = FV of a lump-sum

B = PV of a lump-sum

C = FV of an annuity

D = Sinking fund payment

E = Installment payment

F = PV of an annuity

For the following problems, Classify, by writing the appropriate letter in the box, and write an equation for solution.

Exercise 10.69*(Solution on p. 166.)*

What monthly deposits made to an account paying 9% will grow to \$10,000 in 4 years?

Exercise 10.70

An amount of \$4000 is invested at 6% compounded daily. What will the final amount be in 5 years?

Exercise 10.71*(Solution on p. 166.)*

David has won a lottery paying him \$10,000 per month for the next 20 years. He'd rather have the whole amount in one lump sum now. If the current interest rate is 7%, how much money can he hope to get?

Exercise 10.72

Each month Linda deposits \$250 in an account that pays 9%. How much money will she have in 4 years?

Exercise 10.73*(Solution on p. 166.)*

Find the monthly payment for a \$15,000 car if the loan is amortized over 4 years at a rate of 10%.

Exercise 10.74

What lump-sum deposited in an account paying 7% compounded daily will grow to \$10,000 in 5 years?

Exercise 10.75*(Solution on p. 166.)*

What amount of quarterly payments will amount to \$250,000 in 5 years at a rate of 8%?

Exercise 10.76

The Chang family bought their house 25 years ago. They had their loan financed for 30 years at an interest rate of 11% resulting in a payment of \$1350 a month. Find the balance of the loan.

Exercise 10.77*(Solution on p. 166.)*

A 10-year \$1000 bond pays \$35 every six months. If the current interest rate is 8%, in order to find the fair market value of the bond, we need to find the following.

- a. The present value of \$1000.

Exercise 10.78

A 10-year \$1000 bond pays \$35 every six months. If the current interest rate is 8%, in order to find the fair market value of the bond, we need to find the following.

- b. The present value of the \$35 per six month payments.

Exercise 10.79*(Solution on p. 166.)*

What lump-sum deposit made today is equal to 33 monthly deposits of \$500 if the interest rate is 8%?

Exercise 10.80

What should be the size of the monthly deposits made to an account paying 10% so that their accumulated value will be \$10,000 in six years?

Exercise 10.81*(Solution on p. 166.)*

A department store charges a finance charge of 1.5% per month on the outstanding balance. If Ned charged \$400 three months ago and has not paid his bill, how much does he owe?

Exercise 10.82

What will the value of \$300 monthly deposits be in 10 years if the account pays 12% compounded monthly?

Exercise 10.83*(Solution on p. 166.)*

What lump-sum deposited at 6% compounded daily will grow to \$2000 in three years?

Exercise 10.84

A company buys an apartment complex for \$5,000,000 and amortizes the loan over 10 years. What is the yearly payment if the interest rate is 14%?

Exercise 10.85*(Solution on p. 166.)*

In 1970, a house in Reno cost \$23,000. If the inflation rate is 8%, what is the price of that house in 1997?

Exercise 10.86

You determine that you can afford to pay \$400 per month for a car. What is the maximum price you can pay for a car if the interest rate is 11% and you want to repay the loan in 4 years?

Exercise 10.87*(Solution on p. 166.)*

A business needs \$350,000 in 5 years. How much lump-sum should be put aside in an account that pays 9% so that five years from now the company will have \$350,000?

Exercise 10.88

A person wishes to have \$500,000 in a pension fund 20 years from now. How much should he deposit each month in an account paying 9% compounded monthly?

10.7 CHAPTER REVIEW

Exercise 10.89 *(Solution on p. 166.)*

Manuel borrows \$800 for 6 months at 18% simple interest. How much does he owe at the end of 6 months?

Exercise 10.90 *(Solution on p. 166.)*

The population of California is 32 million and expects to grow at a rate of 2.3% per year for the next 10 years. What will the population of California be in 10 years?

Exercise 10.91 *(Solution on p. 166.)*

The Gill family is buying a \$250,000 house with a 10% down payment. If the loan is financed over a 30 year period at an interest rate of 9.8%, what is the monthly payment?

Exercise 10.92 *(Solution on p. 166.)*

Find the monthly payment for the house in the above problem if the loan was amortized over 15 years.

Exercise 10.93 *(Solution on p. 166.)*

You look at your budget and decide that you can afford \$250 per month for a car. What is the maximum amount you can afford to pay for the car if the interest rate is 8.6% and you want to finance the loan over 5 years?

Exercise 10.94 *(Solution on p. 167.)*

Mr. Nakahama bought his house in 1980. He had his loan financed for 30 years at an interest rate of 11.2% resulting in a monthly payment of \$1500. In 1997, 17 years later, he paid off the balance of the loan. How much did he pay?

Exercise 10.95 *(Solution on p. 167.)*

Lisa buys a car for \$16,500, and receives \$2400 for her old car as a trade-in value. Find the monthly payment for the balance if the loan is amortized over 5 years at 8.5%.

Exercise 10.96 *(Solution on p. 167.)*

A car is sold for \$3000 cash down and \$400 per month for the next 4 years. Find the cash value of the car today if the money is worth 8.3% compounded monthly.

Exercise 10.97 *(Solution on p. 167.)*

An amount of \$2300 is borrowed for 7 months at a simple interest rate of 16%. Find the discount and the proceeds.

Exercise 10.98 *(Solution on p. 167.)*

Marcus has won a lottery paying him \$5000 per month for the next 25 years. He'd rather have the whole amount in one lump sum today. If the current interest rate is 7.3%, how much money can he hope to get?

Exercise 10.99 *(Solution on p. 167.)*

In 1970, an average house in Cupertino cost \$41,000. If the average inflation rate for the past years has been about 9.3%, what is the price of that house in 1997?

Exercise 10.100 *(Solution on p. 167.)*

Find the 'fair market' value of a ten-year \$1000 bond which pays \$30 every six months if the current interest rate is 7%. What if the current interest rate is 5%?

Exercise 10.101 *(Solution on p. 167.)*

A Visa credit card company has a finance charge of 1.5% per month (or 18% per year) on the outstanding balance. John owed \$3200 and has been delinquent for 5 months. How much total does he owe, now?

Exercise 10.102 *(Solution on p. 167.)*

You want to purchase a home for \$200,000 with a 30-year mortgage at 9.24% interest. Find a) the monthly payment and b) the balance owed after 20 years.

Exercise 10.103 *(Solution on p. 167.)*

When Jose bought his car, he amortized his loan over 6 years at a rate of 9.2%, and his monthly payment came out to be \$350 per month. He has been making these payments for the past 40 months and now wants to pay off the remaining balance. How much does he owe?

Exercise 10.104 *(Solution on p. 167.)*

A lottery pays \$10,000 per month for the next 20 years. If the interest rate is 7.8%, find both its present and future values.

Exercise 10.105 *(Solution on p. 167.)*

A corporation estimates it will need \$300,000 in 8 years to replace its existing machinery. How much should it deposit each quarter in a sinking fund earning 8.4% compounded quarterly to meet this obligation?

Exercise 10.106 *(Solution on p. 167.)*

Our national debt in 1992 was about \$4 trillion. If the annual interest rate was 7% then, what was the daily interest on the national debt?

Exercise 10.107 *(Solution on p. 167.)*

A business must raise \$400,000 in 10 years. What should be the size of the owners' monthly payments to a sinking fund paying 6.5% compounded monthly?

Exercise 10.108 *(Solution on p. 167.)*

The population of a city of 80,000 is growing at a rate of 3.2% per year. What will the population be at the end of 10 years?

Exercise 10.109 *(Solution on p. 167.)*

A sum of \$5000 is deposited in a bank today. What will the final amount be in 20 months if the bank pays 9% and the interest is compounded monthly?

Exercise 10.110 *(Solution on p. 167.)*

A computer is sold for \$500 cash and \$50 per month for the next 3 years. Find the cash value of the computer today if the money is worth 6.2% compounded monthly.

Exercise 10.111 *(Solution on p. 167.)*

The United States paid about 4 cents an acre for the Louisiana Purchase in 1803. Suppose the value of this property grew at a rate of 5.5% annually. What would an acre be worth in the year 2000?

Exercise 10.112 *(Solution on p. 167.)*

What amount should be invested per month at 9.1% compounded monthly so that it will become \$5000 in 17 months?

Exercise 10.113 *(Solution on p. 167.)*

A machine costs \$8000 and has a life of 5 years. It can be leased for \$160 per month for 5 years with a cash down payment of \$750. If the current interest rate is 8.3%, is it cheaper to lease or to buy?

Exercise 10.114 *(Solution on p. 167.)*

If inflation holds at 5.2% per year for 5 years, what will be the cost in 5 years of a car that costs \$16,000 today? How much will you need to deposit each quarter in a sinking fund earning 8.7% per year to purchase the new car in 5 years?

Exercise 10.115 *(Solution on p. 167.)*

City Bank pays an interest rate of 6%, while Western Bank pays 5.8% compounded continuously. Which one is a better deal?

Exercise 10.116 *(Solution on p. 167.)*

Ali has inherited \$20,000 and is planning to invest this amount at 7.9% interest. At the same time he wishes to make equal monthly withdrawals to use up the entire sum in 5 years. How much can he withdraw each month?

Exercise 10.117 *(Solution on p. 167.)*

Jason has a choice of receiving \$300 per month for the next 5 years or \$500 per month for the next 3 years. Which one is worth more if the current interest rate is 7.7%?

Exercise 10.118 *(Solution on p. 167.)*

If a bank pays 6.8% compounded continuously, how long will it take to double your money?

Exercise 10.119 *(Solution on p. 168.)*

Janus Mutual Funds claims a growth rate of 17% per year. If \$500 per month is invested, what will the final amount be in 15 years?

Exercise 10.120 *(Solution on p. 168.)*

Mr. Vasquez has been given two choices for his compensation. He can have \$20,000 cash plus \$500 per month for 10 years, or he can receive \$12,000 cash plus \$1000 per month for 5 years. If the interest rate is 8%, which is the better offer?

Exercise 10.121 *(Solution on p. 168.)*

How much should Mr. Shackley deposit in a trust account so that his daughter can withdraw \$400 per month for 4 years if the interest rate is 8%?

Exercise 10.122 *(Solution on p. 168.)*

Mr. Albers borrowed \$425,000 from the bank for his new house at an interest rate of 9%. He will make equal monthly payments for the next 30 years. How much money will he end up paying the bank over the life of the loan, and how much is the interest?

Exercise 10.123 *(Solution on p. 168.)*

Mr. Tong puts away \$500 per month for 10 years in an account that earns 9.3%. After 10 years, he decides to withdraw \$1,000 per month. If the interest rate stays the same, how long will it take Mr. Tong to deplete the account?

Exercise 10.124

An amount of \$5000 is borrowed for 15 months at an interest rate of 9%. Determine the monthly payment and construct an amortization schedule showing the monthly payment, the monthly interest on the outstanding balance, the amount of payment contributing towards debt, and the outstanding debt.

Solutions to Exercises in Chapter 10

Solutions to Mathematics of Finance: Homework

Solution to Exercise 10.1 (p. 155)

\$600

Solution to Exercise 10.3 (p. 155)

\$3048

Solution to Exercise 10.5 (p. 155)

\$1800

Solution to Exercise 10.7 (p. 155)

\$872

Solution to Exercise 10.9 (p. 155)

11%

Solution to Exercise 10.11 (p. 156)

Discount \$240, Proceeds \$1760

Solution to Exercise 10.13 (p. 156)

\$7440

Solution to Exercise 10.15 (p. 156)

\$2790.70

Solution to Exercise 10.17 (p. 156)

\$11542.52

Solution to Exercise 10.19 (p. 156)

\$5647.77

Solution to Exercise 10.21 (p. 156)

Bank B

Solution to Exercise 10.23 (p. 156)

\$12702.00

Solution to Exercise 10.25 (p. 157)

8.66 years

Solution to Exercise 10.27 (p. 157)

\$151257.12

Solution to Exercise 10.29 (p. 157)

7.3967%

Solution to Exercise 10.31 (p. 157)

57.96 million

Solution to Exercise 10.33 (p. 157)

\$13,954.01

Solution to Exercise 10.35 (p. 157)

\$15,904.47

Solution to Exercise 10.37 (p. 157)

\$20,578.36

Solution to Exercise 10.39 (p. 158)

\$6,438.02

Solution to Exercise 10.41 (p. 158)

a lump sum of \$25,000

Solution to Exercise 10.43 (p. 158)

\$112,552.26

Solution to Exercise 10.45 (p. 158)

\$1,177,953.55

Solution to Exercise 10.47 (p. 158)

\$12,043.34

Solution to Exercise 10.49 (p. 158)

\$2,149.21

Solution to Exercise 10.51 (p. 158)

\$1,354.45

Solution to Exercise 10.53 (p. 159)

Leasing is better

Solution to Exercise 10.55 (p. 159)

\$3,690.22

Solution to Exercise 10.57 (p. 159)

\$1,814.54

Solution to Exercise 10.59 (p. 159)

\$187,161.43

Solution to Exercise 10.61 (p. 159)

\$5483.87

Solution to Exercise 10.63 (p. 159)

\$11,046.79

Solution to Exercise 10.65 (p. 159)

\$333.85

Solution to Exercise 10.67 (p. 160)

a. \$447.70

b. \$471.48

c. \$919.18

Solution to Exercise 10.69 (p. 160)

D

Solution to Exercise 10.71 (p. 160)

F

Solution to Exercise 10.73 (p. 160)

E

Solution to Exercise 10.75 (p. 161)

D

Solution to Exercise 10.77 (p. 161)

B

Solution to Exercise 10.79 (p. 161)

F

Solution to Exercise 10.81 (p. 161)

A

Solution to Exercise 10.83 (p. 161)

B

Solution to Exercise 10.85 (p. 161)

A

Solution to Exercise 10.87 (p. 161)

B

Solution to Exercise 10.89 (p. 162)

\$874.75

Solution to Exercise 10.90 (p. 162)

40.17 million

Solution to Exercise 10.91 (p. 162)

\$1,941.36

Solution to Exercise 10.92 (p. 162)

\$2,390.41

- Solution to Exercise 10.93 (p. 162)**
\$12,156.72
- Solution to Exercise 10.94 (p. 162)**
\$122,987.10
- Solution to Exercise 10.95 (p. 162)**
\$289.28
- Solution to Exercise 10.96 (p. 162)**
\$19,290.63
- Solution to Exercise 10.97 (p. 162)**
\$214.67; \$2,085.33
- Solution to Exercise 10.98 (p. 162)**
\$688,675.54
- Solution to Exercise 10.99 (p. 162)**
\$452,405.87
- Solution to Exercise 10.100 (p. 162)**
\$928.94; \$1,077.95
- Solution to Exercise 10.101 (p. 162)**
\$3,447.31
- Solution to Exercise 10.102 (p. 162)**
\$1643.9; \$128451.61
- Solution to Exercise 10.103 (p. 163)**
\$9,898.48
- Solution to Exercise 10.104 (p. 163)**
\$1,213,539.16; \$5,745,936.31
- Solution to Exercise 10.105 (p. 163)**
\$6,669.70
- Solution to Exercise 10.106 (p. 163)**
\$767,123,287.67
- Solution to Exercise 10.107 (p. 163)**
\$2,375.25
- Solution to Exercise 10.108 (p. 163)**
\$109,619.28
- Solution to Exercise 10.109 (p. 163)**
\$5,805.92
- Solution to Exercise 10.110 (p. 163)**
\$2,138.67
- Solution to Exercise 10.111 (p. 163)**
\$1523.33
- Solution to Exercise 10.112 (p. 163)**
\$276.68
- Solution to Exercise 10.113 (p. 163)**
Cheaper to buy
- Solution to Exercise 10.114 (p. 163)**
\$833.80
- Solution to Exercise 10.115 (p. 163)**
City Bank
- Solution to Exercise 10.116 (p. 163)**
\$404.57
- Solution to Exercise 10.117 (p. 164)**
\$500/month for 3 yrs

Solution to Exercise 10.118 (p. 164)

10.19 yrs

Solution to Exercise 10.119 (p. 164)

\$408,705.02

Solution to Exercise 10.120 (p. 164)

\$12000 cash + \$1000/month

Solution to Exercise 10.121 (p. 164)

\$16,384.77

Solution to Exercise 10.122 (p. 164)

\$806,072.60

Solution to Exercise 10.123 (p. 164)

15.53 yrs

Chapter 11

Sets and Counting¹

11.1 Chapter Overview

In this chapter, you will learn to:

1. Use set theory and Venn diagrams to solve counting problems.
2. Use the Multiplication Axiom to solve counting problems.
3. Use Permutations to solve counting problems.
4. Use Combinations to solve counting problems.
5. Use the Binomial Theorem to expand $(x + y)^n$.

11.2 Sets

In this section, we will familiarize ourselves with set operations and notations, so that we can apply these concepts to both counting and probability problems. We begin by defining some terms.

A **set** is a collection of objects, and its members are called the **elements** of the set. We name the set by using capital letters, and enclose its members in braces. Suppose we need to list the members of the chess club. We use the following set notation.

$$C = \{\text{Ken, Bob, Tran, Shanti, Eric}\} \quad (11.1)$$

A set that has no members is called an **empty set**. The empty set is denoted by the symbol \emptyset .

Two sets are **equal** if they have the same elements.

A set A is a **subset** of a set B if every member of A is also a member of B .

Suppose $C = \{\text{Al, Bob, Chris, David, Ed}\}$ and $A = \{\text{Bob, David}\}$. Then A is a subset of C , written as $A \subseteq C$.

Every set is a subset of itself, and the empty set is a subset of every set.

Union Of Two Sets

Let A and B be two sets, then the union of A and B , written as $A \cup B$, is the set of all elements that are either in A or in B , or in both A and B .

Intersection Of Two Sets

Let A and B be two sets, then the intersection of A and B , written as $A \cap B$, is the set of all elements that are common to both sets A and B .

A **universal set** U is the set consisting of all elements under consideration.

¹This content is available online at <<http://cnx.org/content/m18906/1.2/>>.

Complement of a Set

Let A be any set, then the complement of set A , written as $\overset{\Psi}{A}$, is the set consisting of elements in the universal set U that are not in A .

Disjoint Sets

Two sets A and B are called disjoint sets if their intersection is an empty set.

Example 11.1

List all the subsets of the set of primary colors {red, yellow, blue}.

Solution

The subsets are \emptyset , {red}, {yellow}, {blue}, {red, yellow}, {red, blue}, {yellow, blue}, {red, yellow, blue}

Note that the empty set is a subset of every set, and a set is a subset of itself.

Example 11.2

Let $F = \{\text{Aikman, Jackson, Rice, Sanders, Young}\}$, and $B = \{\text{Griffey, Jackson, Sanders, Thomas}\}$. Find the intersection of the sets F and B .

Solution

The intersection of the two sets is the set whose elements belong to both sets. Therefore,

$$F \cap B = \{\text{Jackson, Sanders}\} \quad (11.2)$$

Example 11.3

Find the union of the sets F and B given as follows.

$$F = \{\text{Aikman, Jackson, Rice, Sanders, Young}\} B = \{\text{Griffey, Jackson, Sanders, Thomas}\} \quad (11.3)$$

Solution

The union of two sets is the set whose elements are either in A or in B or in both A and B . Therefore

$$F \cup B = \{\text{Aikman, Griffey, Jackson, Rice, Sanders, Thomas, Young}\} \quad (11.4)$$

Observe that when writing the union of two sets, the repetitions are avoided.

Example 11.4

Let the universal set $U = \{\text{red, orange, yellow, green, blue, indigo, violet}\}$, and $P = \{\text{red, yellow, blue}\}$. Find the complement of P .

Solution

The complement of a set P is the set consisting of elements in the universal set U that are not in P . Therefore,

$$\overset{\Psi}{P} = \{\text{orange, green, indigo, violet}\} \quad (11.5)$$

To achieve a better understanding, let us suppose that the universal set U represents the colors of the spectrum, and P the primary colors, then \overline{P} represents those colors of the spectrum that are not primary colors.

Example 11.5

Let $U = \{\text{red, orange, yellow, green, blue, indigo, violet}\}$, $P = \{\text{red, yellow, blue}\}$, $Q = \{\text{red, green}\}$, and $R = \{\text{orange, green, indigo}\}$. Find $\overline{P \cup Q} \cap \overline{R}$.

Solution

We do the problems in steps.

$$\begin{aligned} P \cup Q &= \{\text{red, yellow, blue, green}\} \\ \overline{P \cup Q} &= \{\text{orange, indigo, violet}\} \\ \overline{R} &= \{\text{red, yellow, blue, violet}\} \\ \overline{P \cup Q} \cap \overline{R} &= \{\text{violet}\} \end{aligned} \tag{11.6}$$

We now use Venn diagrams to illustrate the relations between sets. In the late 1800s, an English logician named John Venn developed a method to represent relationship between sets. He represented these relationships using diagrams, which are now known as Venn diagrams. A Venn diagram represents a set as the interior of a circle. Often two or more circles are enclosed in a rectangle where the rectangle represents the universal set. To visualize an intersection or union of a set is easy. In this section, we will mainly use Venn diagrams to sort various populations and count objects.

Example 11.6

Suppose a survey of car enthusiasts showed that over a certain time period, 30 drove cars with automatic transmissions, 20 drove cars with standard transmissions, and 12 drove cars of both types. If every one in the survey drove cars with one of these transmissions, how many people participated in the survey?

Solution

We will use Venn diagrams to solve this problem.

Let the set A represent those car enthusiasts who drove cars with automatic transmissions, and set S represent the car enthusiasts who drove the cars with standard transmissions. Now we use Venn diagrams to sort out the information given in this problem.

Since 12 people drove both cars, we place the number 12 in the region common to both sets.

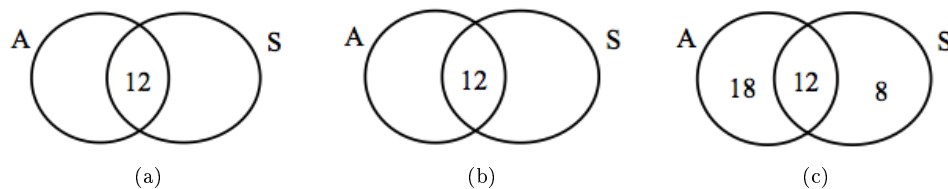

Figure 11.1

Because 30 people drove cars with automatic transmissions, the circle A must contain 30 elements. This means $x + 12 = 30$, or $x = 18$. Similarly, since 20 people drove cars with standard transmissions, the circle B must contain 20 elements, or $y + 12 = 20$ which in turn makes $y = 8$.

Now that all the information is sorted out, it is easy to read from the diagram that 18 people drove cars with automatic transmissions only, 12 people drove both types of cars, and 8 drove cars with standard transmissions only. Therefore, $18 + 12 + 8 = 38$ people took part in the survey.

Example 11.7

A survey of 100 people in California indicates that 60 people have visited Disneyland, 15 have visited Knott's Berry Farm, and 6 have visited both. How many people have visited neither place?

Solution

The problem is similar to the one in Example 11.6.

Let the set D represent the people who have visited Disneyland, and K the set of people who have visited Knott's Berry Farm.

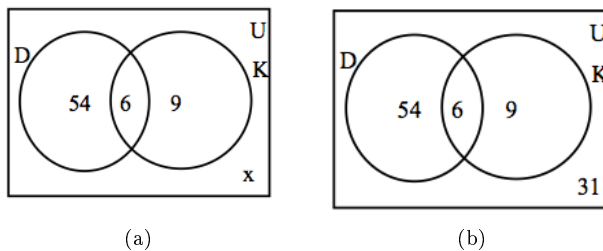

Figure 11.2

We fill the three regions associated with the sets D and K in the same manner as before. Since 100 people participated in the survey, the rectangle representing the universal set U must contain 100 objects. Let x represent those people in the universal set that are neither in the set D nor in K . This means $54 + 6 + 9 + x = 100$, or $x = 31$.

Therefore, there are 31 people in the survey who have visited neither place.

Example 11.8

A survey of 100 exercise conscious people resulted in the following information:

- 50 jog, 30 swim, and 35 cycle
- 14 jog and swim
- 7 swim and cycle
- 9 jog and cycle
- 3 people take part in all three activities

- a. How many jog but do not swim or cycle?
- b. How many take part in only one of the activities?
- c. How many do not take part in any of these activities?

Solution

Let J represent the set of people who jog, S the set of people who swim, and C who cycle.

In using Venn diagrams, our ultimate aim is to assign a number to each region. We always begin by first assigning the number to the innermost region and then working our way out.

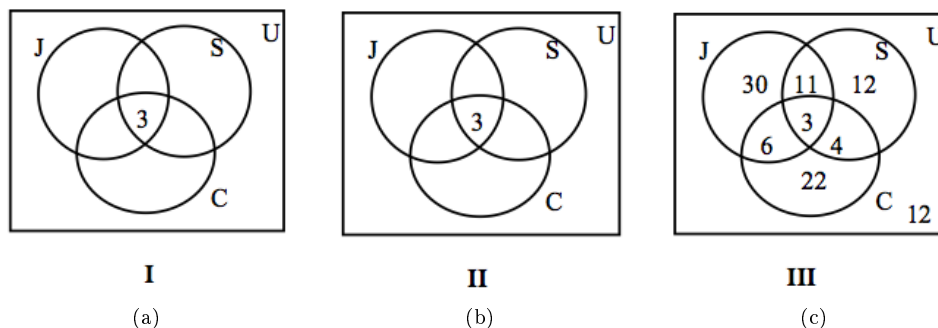

Figure 11.3

We place a 3 in the innermost region of Figure 11.3(a) because it represents the number of people who participate in all three activities. Next we compute x , y and z .

Since 14 people jog and swim, $x + 3 = 14$, or $x = 11$.

The fact that 9 people jog and cycle results in $y + 3 = 9$, or $y = 6$.

Since 7 people swim and cycle, $z + 3 = 7$, or $z = 4$.

This information is depicted in Figure 11.3(b).

Now we proceed to find the unknowns m , n and p .

Since 50 people jog, $m + 11 + 6 + 3 = 50$, or $m = 30$.

Thirty people swim, therefore, $n + 11 + 4 + 3 = 30$, or $n = 12$.

Thirty five people cycle, therefore, $p + 6 + 4 + 3 = 35$, or $p = 22$.

By adding all the entries in all three sets, we get a sum of 88. Since 100 people were surveyed, the number inside the universal set but outside of all three sets is $100 - 88$, or 12.

In Figure 11.3(c), the information is sorted out, and the questions can readily be answered.

- The number of people who jog but do not swim or cycle is 30.
- The number who take part in only one of these activities is $30 + 12 + 22 = 64$.
- The number of people who do not take part in any of these activities is 12.

11.3 Tree Diagrams and the Multiplication Axiom

In this chapter, we are trying to develop counting techniques that will be used in the Chapter 13 to study probability. One of the most fundamental of such techniques is called the Multiplication Axiom. Before we introduce the multiplication axiom, we first look at some examples.

Example 11.9

If a woman has two blouses and three skirts, how many different outfits consisting of a blouse and a skirt can she wear?

Solution

Suppose we call the blouses b_1 and b_2 , and skirts s_1 , s_2 , and s_3 .

We can have the following six outfits.

$$b_1s_1, b_1s_2, b_1s_3, b_2s_1, b_2s_2, b_2s_3 \quad (11.7)$$

Alternatively, we can draw a tree diagram:

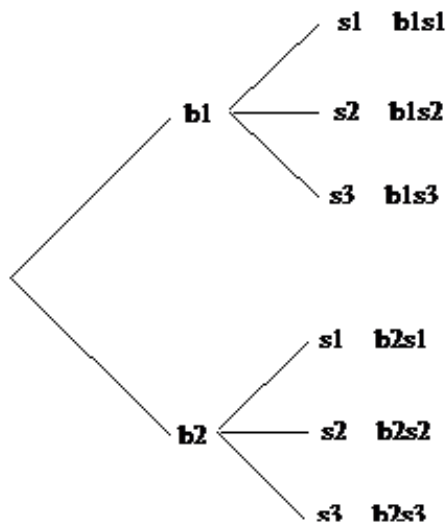

Figure 11.4

The tree diagram gives us all six possibilities. The method involves two steps. First the woman chooses a blouse. She has two choices: blouse one or blouse two. If she chooses blouse one, she has three skirts to match it with; skirt one, skirt two, or skirt three. Similarly if she chooses blouse two, she can match it with each of the three skirts, again. The tree diagram helps us visualize these possibilities.

The reader should note that the process involves two steps. For the first step of choosing a blouse, there are two choices, and for each choice of a blouse, there are three choices of choosing a skirt. So altogether there are $2 \cdot 3 = 6$ possibilities.

If, in the above example, we add the shoes to the outfit, we have the following problem.

Example 11.10

If a woman has two blouses, three skirts, and two pumps, how many different outfits consisting of a blouse, a skirt, and a pair of pumps can she wear?

Solution

Suppose we call the blouses b_1 and b_2 , the skirts s_1 , s_2 , and s_3 , and the pumps p_1 , and p_2 .

The following tree diagram results.

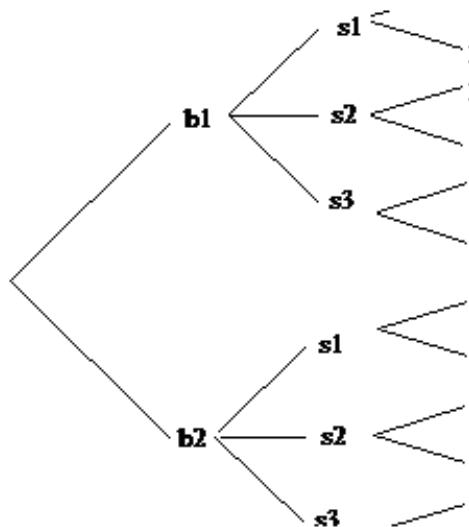

Figure 11.5

We count the number of branches in the tree, and see that there are 12 different possibilities. This time the method involves three steps. First, the woman chooses a blouse. She has two choices: blouse one or blouse two. Now suppose she chooses blouse one. This takes us to step two of the process which consists of choosing a skirt. She has three choices for a skirt, and let us suppose she chooses skirt two. Now that she has chosen a blouse and a skirt, we have moved to the third step of choosing a pair of pumps. Since she has two pairs of pumps, she has two choices for the last step. Let us suppose she chooses pumps two. She has chosen the outfit consisting of blouse one, skirt two, and pumps two, or $b_1 s_2 p_2$. By looking at the different branches on the tree, one can easily see the other possibilities.

The important thing to observe here, again, is that this is a three step process. There are two choices for the first step of choosing a blouse. For each choice of a blouse, there are three choices of choosing a skirt, and for each combination of a blouse and a skirt, there are two choices of selecting a pair of pumps. All in all, we have $2 \cdot 3 \cdot 2 = 12$ different possibilities.

The tree diagrams help us visualize the different possibilities, but they are not practical when the possibilities are numerous. Besides, we are mostly interested in finding the number of elements in the set and not the actual possibilities. But once the problem is envisioned, we can solve it without a tree diagram. The two examples we just solved may have given us a clue to do just that.

Let us now try to solve Example 11.10 without a tree diagram. Recall that the problem involved three steps: choosing a blouse, choosing a skirt, and choosing a pair of pumps. The number of ways of choosing each are listed below.

The Number of ways of choosing a blouse	The number of ways of choosing a skirt	The number of ways of choosing pumps
2	3	2

Table 11.1

By multiplying these three numbers we get 12, which is what we got when we did the problem using a tree diagram.

The procedure we just employed is called the multiplication axiom.

11.11: THE MULTIPLICATION AXIOM

If a task can be done in m ways, and a second task can be done in n ways, then the operation involving the first task followed by the second can be performed in $m \cdot n$ ways.

The general multiplication axiom is not limited to just two tasks and can be used for any number of tasks.

Example 11.12

A truck license plate consists of a letter followed by four digits. How many such license plates are possible?

Solution

Since there are 26 letters and 10 digits, we have the following choices for each.

Letter	Digit	Digit	Digit	Digit
26	10	10	10	10

Table 11.2

Therefore, the number of possible license plates is $26 \cdot 10 \cdot 10 \cdot 10 \cdot 10 = 260,000$.

Example 11.13

In how many different ways can a 3-question true-false test be answered?

Solution

Since there are two choices for each question, we have

Question 1	Question 2	Question 3
2	2	2

Table 11.3

Applying the multiplication axiom, we get $2 \cdot 2 \cdot 2 = 8$ different ways.

We list all eight possibilities below.

TTT, TTF, TFT, TFF, FTT, FTF, FFT, FFF

The reader should note that the first letter in each possibility is the answer corresponding to the first question, the second letter corresponds to the answer to the second question and so on. For example, TFF, says that the answer to the first question is given as true, and the answers to the second and third questions false.

Example 11.14

In how many different ways can four people be seated in a row?

Solution

Suppose we put four chairs in a row, and proceed to put four people in these seats.

There are four choices for the first chair we choose. Once a person sits down in that chair, there are only three choices for the second chair, and so on. We list as shown below.

4	3	2	1
---	---	---	---

Table 11.4

So there are altogether $4 \cdot 3 \cdot 2 \cdot 1 = 24$ different ways.

Example 11.15

How many three-letter word sequences can be formed using the letters $\{A, B, C\}$ if no letter is to be repeated?

Solution

The problem is very similar to Example 11.14.

Imagine a child having three building blocks labeled A , B , and C . Suppose he puts these blocks on top of each other to make word sequences. For the first letter he has three choices, namely A , B , or C . Let us suppose he chooses the first letter to be a B , then for the second block which must go on top of the first, he has only two choices: A or C . And for the last letter he has only one choice. We list the choices below.

3	2	1
---	---	---

Table 11.5

Therefore, 6 different word sequences can be formed.

Finally, we'd like to illustrate this with a tree diagram.

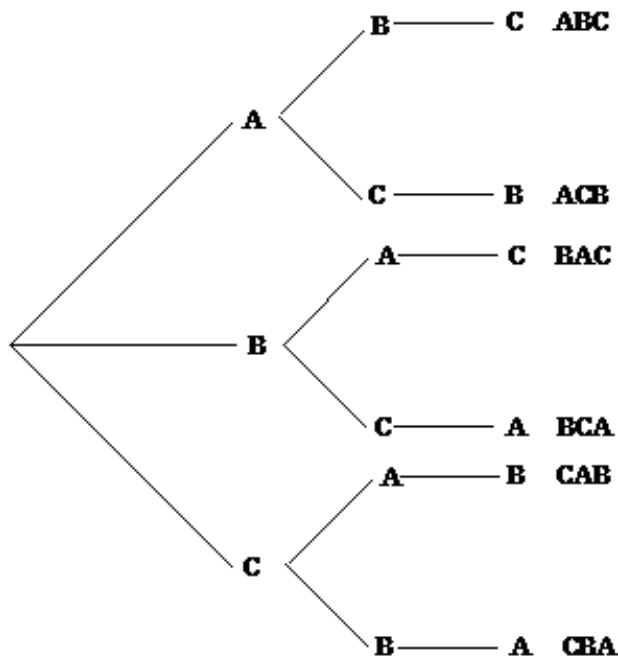

Figure 11.6

All six possibilities are displayed in the tree diagram.

11.4 Permutations

In Example 11.15, we were asked to find the word sequences formed by using the letters $\{A, B, C\}$ if no letter is to be repeated. The tree diagram gave us the following six arrangements.

ABC, ACB, BAC, BCA, CAB, and CBA,

Arrangements like these, where order is important and no element is repeated, are called permutations.

11.16: Permutations

A permutation of a set of elements is an ordered arrangement where each element is used once.

Example 11.17

How many three-letter word sequences can be formed using the letters $\{A, B, C, D\}$?

Solution

There are four choices for the first letter of our word, three choices for the second letter, and two choices for the third.

4	3	2
---	---	---

Table 11.6

Applying the multiplication axiom, we get $4 \cdot 3 \cdot 2 = 24$ different arrangements.

Example 11.18

How many permutations of the letters of the word ARTICLE have consonants in the first and last positions?

Solution

In the word ARTICLE, there are 4 consonants.

Since the first letter must be a consonant, we have four choices for the first position, and once we use up a consonant, there are only three consonants left for the last spot. We show as follows:

4						3
---	--	--	--	--	--	---

Table 11.7

Since there are no more restrictions, we can go ahead and make the choices for the rest of the positions.

So far we have used up 2 letters, therefore, five remain. So for the next position there are five choices, for the position after that there are four choices, and so on. We get

4	5	4	3	2	1	3
---	---	---	---	---	---	---

Table 11.8

So the total permutations are $4 \cdot 5 \cdot 4 \cdot 3 \cdot 2 \cdot 1 \cdot 3 = 1440$.

Example 11.19

Given five letters $\{A, B, C, D, E\}$. Find the following:

- The number of four-letter word sequences.
- The number of three-letter word sequences.
- The number of two-letter word sequences.

Solution

The problem is easily solved by the multiplication axiom, and answers are as follows:

- The number of four-letter word sequences is $5 \cdot 4 \cdot 3 \cdot 2 = 120$.
- The number of three-letter word sequences is $5 \cdot 4 \cdot 3 = 60$.
- The number of two-letter word sequences is $5 \cdot 4 = 20$.

We often encounter situations where we have a set of n objects and we are selecting r objects to form permutations. We refer to this as **permutations of n objects taken r at a time**, and we write it as nPr .

Therefore, Example 11.19 can also be answered as listed below.

- The number of four-letter word sequences is $5P4 = 120$.
- The number of three-letter word sequences is $5P3 = 60$.

- c. The number of two-letter word sequences is $5P2 = 20$.

Before we give a formula for nPr , we'd like to introduce a symbol that we will use a great deal in this as well as in Chapter 13.

11.20: Factorial

$$n! = n(n-1)(n-2)(n-3)\cdots 3 \cdot 2 \cdot 1.$$

Where n is a natural number.

$$0! = 1 \tag{11.8}$$

Now we define nPr .

11.21: The Number of Permutations of n Objects Taken r at a Time

$$nPr = n(n-1)(n-2)(n-3)\cdots(n-r+1), \text{ or}$$

$$nPr = \frac{n!}{(n-r)!}$$

Where n and r are natural numbers.

The reader should become familiar with both formulas and should feel comfortable in applying either.

Example 11.22

Compute the following using both formulas.

- a. $6P3$
- b. $7P2$

Solution

We will identify n and r in each case and solve using the formulas provided.

$$\text{a. } 6P3 = 6 \cdot 5 \cdot 4 = 120, \text{ alternately } 6P3 = \frac{6!}{(6-3)!} = \frac{6!}{3!} = \frac{6 \cdot 5 \cdot 4 \cdot 3 \cdot 2 \cdot 1}{3 \cdot 2 \cdot 1} = 120$$

$$\text{b. } 7P2 = 7 \cdot 6 = 42, \text{ or } 7P2 = \frac{7!}{5!} = \frac{7 \cdot 6 \cdot 5 \cdot 4 \cdot 3 \cdot 2 \cdot 1}{5 \cdot 4 \cdot 3 \cdot 2 \cdot 1} = 42$$

Next we consider some more permutation problems to get further insight into these concepts.

Example 11.23

In how many different ways can 4 people be seated in a straight line if two of them insist on sitting next to each other?

Solution

Let us suppose we have four people A , B , C , and D . Further suppose that A and B want to sit together. For the sake of argument, we tie A and B together and treat them as one person.

The four people are \boxed{AB} CD . Since \boxed{AB} is treated as one person, we have the following possible arrangements.

$$\boxed{AB} CD, \boxed{AB} DC, C \boxed{AB} D, D \boxed{AB} C, CD \boxed{AB}, DC \boxed{AB} \tag{11.9}$$

Note that there are six more such permutations because A and B could also be tied in the order BA . And they are

$$\boxed{BA} CD, \boxed{BA} DC, C \boxed{BA} D, D \boxed{BA} C, CD \boxed{BA}, DC \boxed{BA} \tag{11.10}$$

So altogether there are 12 different permutations.

Let us now do the problem using the multiplication axiom.

After we tie two of the people together and treat them as one person, we can say we have only three people. The multiplication axiom tells us that three people can be seated in $3!$ ways. Since two people can be tied together $2!$ ways, there are $3!2! = 12$ different arrangements.

Example 11.24

You have 4 math books and 5 history books to put on a shelf that has 5 slots. In how many ways can the books be shelved if the first three slots are filled with math books and the next two slots are filled with history books?

Solution

We first do the problem using the multiplication axiom.

Since the math books go in the first three slots, there are 4 choices for the first slot, 3 for the second and 2 for the third. The fourth slot requires a history book, and has five choices. Once that choice is made, there are 4 history books left, and therefore, 4 choices for the last slot. The choices are shown below.

4	3	2	5	4
---	---	---	---	---

Table 11.9

Therefore, the number of permutations are $4 \cdot 3 \cdot 2 \cdot 5 \cdot 4 = 480$.

Alternately, we can see that $4 \cdot 3 \cdot 2$ is really same as $4P3$, and $5 \cdot 4$ is $5P2$.

So the answer can be written as $(4P3) (5P2) = 480$.

Clearly, this makes sense. For every permutation of three math books placed in the first three slots, there are $5P2$ permutations of history books that can be placed in the last two slots. Hence the multiplication axiom applies, and we have the answer $(4P3) (5P2)$.

We summarize.

1. **Permutations** A permutation of a set of elements is an ordered arrangement where each element is used once.
2. **Factorial** $n! = n(n-1)(n-2)(n-3) \cdots 3 \cdot 2 \cdot 1$.
Where n is a natural number.

$$0! = 1 \quad (11.11)$$

3. **Permutations of n Objects Taken r at a Time** $nPr = n(n-1)(n-2)(n-3) \cdots (n-r+1)$,
or $nPr = \frac{n!}{(n-r)!}$
Where n and r are natural numbers.

11.5 Circular Permutations and Permutations with Similar Elements

11.5.1 Section Overview

In this section we will address the following two problems.

1. In how many different ways can five people be seated in a circle?
2. In how many different ways can the letters of the word MISSISSIPPI be arranged?

The first problem comes under the category of Circular Permutations, and the second under Permutations with Similar Elements.

Circular Permutations

Suppose we have three people named A , B , and C . We have already determined that they can be seated in a straight line in $3!$ or 6 ways. Our next problem is to see how many ways these people can be seated in a circle. We draw a diagram.

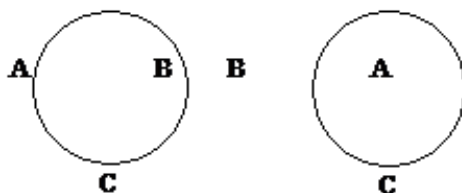

Figure 11.7

It happens that there are only two ways we can seat three people in a circle. This kind of permutation is called a circular permutation. In such cases, no matter where the first person sits, the permutation is not affected. Each person can shift as many places as they like, and the permutation will not be changed. Imagine the people on a merry-go-round; the rotation of the permutation does not generate a new permutation. So in circular permutations, the first person is considered a place holder, and where he sits does not matter.

11.25: Circular Permutations

The number of permutations of n elements in a circle is $(n - 1)!$

Example 11.26

In how many different ways can five people be seated at a circular table?

Solution

We have already determined that the first person is just a place holder. Therefore, there is only one choice for the first spot. We have

1	4	3	2	1
---	---	---	---	---

Table 11.10

So the answer is 24.

Example 11.27

In how many ways can four couples be seated at a round table if the men and women want to sit alternately?

Solution

We again emphasize that the first person can sit anywhere without affecting the permutation.

So there is only one choice for the first spot. Suppose a man sat down first. The chair next to it must belong to a woman, and there are 4 choices. The next chair belongs to a man, so there are three choices and so on. We list the choices below.

1	4	3	3	2	2	1	1
---	---	---	---	---	---	---	---

Table 11.11

So the answer is 144.

Now we address the second problem.

Permutations with Similar Elements

Let us determine the number of distinguishable permutations of the letters ELEMENT.

Suppose we make all the letters different by labeling the letters as follows.

$$E_1LE_2ME_3NT \quad (11.12)$$

Since all the letters are now different, there are $7!$ different permutations.

Let us now look at one such permutation, say

$$LE_1ME_2NE_3T \quad (11.13)$$

Suppose we form new permutations from this arrangement by only moving the E's. Clearly, there are $3!$ or 6 such arrangements. We list them below.

$$LE_1ME_2NE_3T \quad (11.14)$$

$$LE_1ME_3NE_2T \quad (11.15)$$

$$LE_2ME_1NE_3T \quad (11.16)$$

$$LE_3ME_3NE_1T \quad (11.17)$$

$$LE_3ME_2NE_1T \quad (11.18)$$

$$LE_3ME_1NE_2T \quad (11.19)$$

Because the E's are not different, there is only one arrangement LEMENET and not six. This is true for every permutation.

Let us suppose there are n different permutations of the letters ELEMENT.

Then there are $n \cdot 3!$ permutations of the letters $E_1LE_2ME_3NT$.

But we know there are $7!$ permutations of the letters $E_1LE_2ME_3NT$.

Therefore, $n \cdot 3! = 7!$

Or $n = \frac{7!}{3!}$.

This gives us the method we are looking for.

11.28: Permutations with Similar Elements

The number of permutations of n elements taken n at a time, with r_1 elements of one kind, r_2 elements of another kind, and so on, is

$$\frac{n!}{r_1!r_2!\dots r_k!} \quad (11.20)$$

Example 11.29

Find the number of different permutations of the letters of the word MISSISSIPPI.

Solution

The word MISSISSIPPI has 11 letters. If the letters were all different there would have been 11! different permutations. But MISSISSIPPI has 4 S's, 4 I's, and 2 P's that are alike.

So the answer is $\frac{11!}{4!4!2!}$

Which equals 34,650.

Example 11.30

If a coin is tossed six times, how many different outcomes consisting of 4 heads and 2 tails are there?

Solution

Again, we have permutations with similar elements.

We are looking for permutations for the letters HHHHTT.

The answer is $\frac{6!}{4!2!} = 15$.

Example 11.31

In how many different ways can 4 nickels, 3 dimes, and 2 quarters be arranged in a row?

Solution

Assuming that all nickels are similar, all dimes are similar, and all quarters are similar, we have permutations with similar elements. Therefore, the answer is

$$\frac{9!}{4!3!2!} = 1260 \quad (11.21)$$

Example 11.32

A stock broker wants to assign 20 new clients equally to 4 of its salespeople. In how many different ways can this be done?

Solution

This means that each sales person gets 5 clients. The problem can be thought of as an ordered partitions problem. In that case, using the formula we get

$$\frac{20!}{5!5!5!5!} = 11,732,745,024 \quad (11.22)$$

We summarize.

11.33

1. **Circular Permutations** The number of permutations of n elements in a circle is

$$(n - 1)! \quad (11.23)$$

2. **Permutations with Similar Elements** The number of permutations of n elements taken n at a time, with r_1 elements of one kind, r_2 elements of another kind, and so on, such that

$$n = r_1 + r_2 + \cdots + r_k$$

$$\frac{n!}{r_1!r_2!\cdots r_k!}$$

This is also referred to as **ordered partitions**.

11.6 Combinations

Suppose we have a set of three letters $\{A, B, C\}$, and we are asked to make two-letter word sequences. We have the following six permutations.

AB BA BC CB AC CA

Now suppose we have a group of three people $\{A, B, C\}$ as Al, Bob, and Chris, respectively, and we are asked to form committees of two people each. This time we have only three committees, namely,

AB BC AC

When forming committees, the order is not important, because the committee that has Al and Bob is no different than the committee that has Bob and Al. As a result, we have only three committees and not six.

Forming word sequences is an example of permutations, while forming committees is an example of **combinations** – the topic of this section.

Permutations are those arrangements where order is important, while combinations are those arrangements where order is not significant. From now on, this is how we will tell permutations and combinations apart.

In Example 11.32, there were six permutations, but only three combinations.

Just as the symbol nPr represents the number of permutations of n objects taken r at a time, nCr represents the number of combinations of n objects taken r at a time.

So in Example 11.32, $3P2 = 6$, and $3C2 = 3$.

Our next goal is to determine the relationship between the number of combinations and the number of permutations in a given situation.

In Example 11.32, if we knew that there were three combinations, we could have found the number of permutations by multiplying this number by $2!$. That is because each combination consists of two letters, and that makes $2!$ permutations.

Example 11.34

Given the set of letters $\{A, B, C, D\}$. Write the number of combinations of three letters, and then from these combinations determine the number of permutations.

Solution

We have the following four combinations.

ABC BCD CDA BDA

Since every combination has three letters, there are $3!$ permutations for every combination. We list them below.

ABC BCD CDA BDA

ACB BDC CAD BAD

BAC CDB DAC DAB

BCA CBD DCA DBA

CAB DCB ACD ADB

CBA DBC ADC ABD

The number of permutations are $3!$ times the number of combinations. That is

$$4p3 = 3! \cdot 4C3 \tag{11.24}$$

or $4C3 = \frac{4P3}{3!}$

In general, $nCr = \frac{nPr}{r!}$

Since $nPr = \frac{n!}{(n-r)!}$
 We have, $nCr = \frac{n!}{(n-r)!r!}$

Summarizing,

11.35

1. **Combinations** A combination of a set of elements is an arrangement where each element is used once, and order is not important.
2. **The Number of Combinations of n Objects Taken r at a Time** $nCr = \frac{n!}{(n-r)!r!}$
 Where n and r are natural numbers.

Example 11.36

Compute:

- a. $5C3$
- b. $7C3$.

Solution

We use the above formula.

$$5C3 = \frac{5!}{(5-3)!3!} = \frac{5!}{2!3!} = 10 \quad (11.25)$$

$$7C3 = \frac{7!}{(7-3)!3!} = \frac{7!}{4!3!} = 35. \quad (11.26)$$

Example 11.37

In how many different ways can a student select to answer five questions from a test that has seven questions, if the order of the selection is not important?

Solution

Since the order is not important, it is a combination problem, and the answer is

$$7C5 = 21.$$

Example 11.38

How many line segments can be drawn by connecting any two of the six points that lie on the circumference of a circle?

Solution

Since the line that goes from point A to point B is same as the one that goes from B to A , this is a combination problem.

It is a combination of 6 objects taken 2 at a time. Therefore, the answer is

$$6C2 = \frac{6!}{4!2!} = 15 \quad (11.27)$$

Example 11.39

There are ten people at a party. If they all shake hands, how many hand-shakes are possible?

Solution

Note that between any two people there is only one hand shake. Therefore, we have

$${}_{10}C_2 = 45 \text{ hand-shakes.} \quad (11.28)$$

Example 11.40

The shopping area of a town is in the shape of square that is 5 blocks by 5 blocks. How many different routes can a taxi driver take to go from one corner of the shopping area to the opposite cater-corner?

Solution

Let us suppose the taxi driver drives from the point A , the lower left hand corner, to the point B , the upper right hand corner as shown in the figure below.

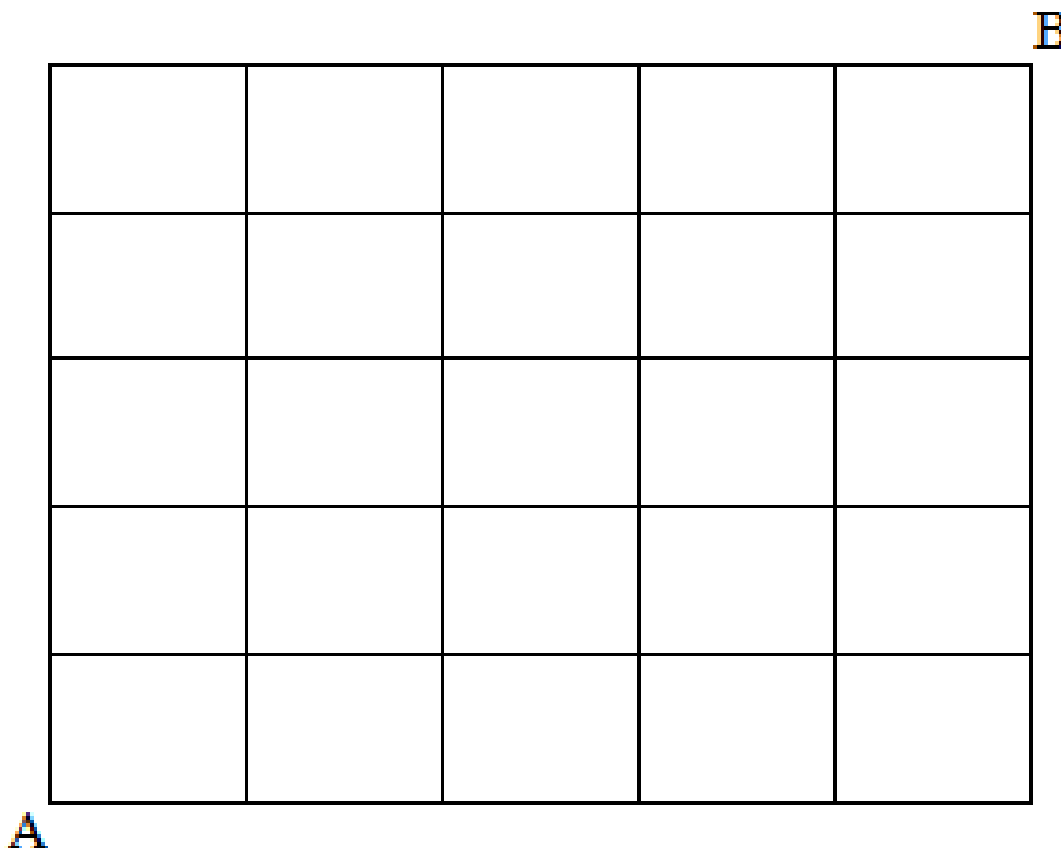

Figure 11.8

To reach his destination, he has to travel ten blocks; five horizontal, and five vertical. So if out of the ten blocks he chooses any five horizontal, the other five will have to be the vertical blocks, and vice versa. Therefore, all he has to do is to choose 5 out of ten.

The answer is ${}^{10}C_5$, or 252.

Alternately, the problem can be solved by permutations with similar elements.

The taxi driver's route consists of five horizontal and five vertical blocks. If we call a horizontal block H , and a vertical block a V , then one possible route may be as follows.

$$\text{HHHHHVVVVV} \quad (11.29)$$

Clearly there are $\frac{10!}{5!5!} = 252$ permutations.

Further note that by definition ${}^{10}C_5 = \frac{10!}{5!5!}$.

Example 11.41

If a coin is tossed six times, in how many ways can it fall four heads and two tails?

Solution

First we solve this problem using Section 11.6 (Combinations) technique—permutations with similar elements.

We need 4 heads and 2 tails, that is

$$\text{HHHHTT} \quad (11.30)$$

There are $\frac{6!}{4!2!} = 15$ permutations.

Now we solve this problem using combinations.

Suppose we have six spots to put the coins on. If we choose any four spots for heads, the other two will automatically be tails. So the problem is simply

$${}^6C_4 = 15.$$

Incidentally, we could have easily chosen the two tails, instead. In that case, we would have gotten

$${}^6C_2 = 15.$$

Further observe that by definition

$${}^6C_4 = \frac{6!}{2!4!} \quad (11.31)$$

and ${}^6C_2 = \frac{6!}{4!2!}$
Which implies

$${}^6C_4 = {}^6C_2. \quad (11.32)$$

11.7 Combinations: Involving Several Sets

So far we have solved the basic combination problem of r objects chosen from n different objects. Now we will consider certain variations of this problem.

Example 11.42

How many five-person committees consisting of 2 men and 3 women can be chosen from a total of 4 men and 4 women?

Solution

We list 4 men and 4 women as follows:

$$M_1M_2M_3M_4W_1W_2W_3W_4 \quad (11.33)$$

Since we want 5-person committees consisting of 2 men and 3 women, we'll first form all possible two-man committees and all possible three-woman committees. Clearly there are ${}^4C_2 = 6$ two-man committees, and ${}^4C_3 = 4$ three-woman committees, we list them as follows:

2-Man Committees	3-Woman Committees
M_1M_2	$W_1W_2W_3$
M_1M_3	$W_1W_2W_4$
M_1M_4	$W_1W_3W_4$
M_2M_3	$W_2W_3W_4$
M_2M_4	
M_3M_4	

Table 11.12

For every 2-man committee there are four 3-woman committees that can be chosen to make a 5-person committee. If we choose M_1M_2 as our 2-man committee, then we can choose any of $W_1W_2W_3$, $W_1W_2W_4$, $W_1W_3W_4$, or $W_2W_3W_4$ as our 3-woman committees. As a result, we get

$$\boxed{M_1M_2}, W_1W_2W_3 \boxed{M_1M_2}, W_1W_2W_4 \boxed{M_1M_2}, W_1W_3W_4 \boxed{M_1M_2}, W_2W_3W_4 \quad (11.34)$$

Similarly, if we choose M_1M_3 as our 2-man committee, then, again, we can choose any of $W_1W_2W_3$, $W_1W_2W_4$, $W_1W_3W_4$, or $W_2W_3W_4$ as our 3-woman committees.

$$\boxed{M_1M_3}, W_1W_2W_3 \boxed{M_1M_3}, W_1W_2W_4 \boxed{M_1M_3}, W_1W_3W_4 \boxed{M_1M_3}, W_2W_3W_4 \quad (11.35)$$

And so on.

Since there are six 2-man committees, and for every 2-man committee there are four 3-woman committees, there are altogether $6 \cdot 4 = 24$ five-people committees.

In essence, we are applying the multiplication axiom to the different combinations.

Example 11.43

A high school club consists of 4 freshmen, 5 sophomores, 5 juniors, and 6 seniors. How many ways can a committee of 4 people be chosen that includes

- One student from each class?
- All juniors?
- Two freshmen and 2 seniors?
- No freshmen?
- At least three seniors?

Solution

- Applying the multiplication axiom to the combinations involved, we get

$$4C1 \cdot 5C1 \cdot 5C1 \cdot 6C1 = 600 \quad (11.36)$$

- We are choosing all 4 members from the 5 juniors, and none from the others.

$$5C4 = 5 \quad (11.37)$$

- $4C2 \cdot 6C2 = 90$

- d. Since we don't want any freshmen on the committee, we need to choose all members from the remaining 16. That is

$${}_{16}C_4 = 1820 \quad (11.38)$$

- e. Of the 4 people on the committee, we want at least three seniors. This can be done in two ways. We could have three seniors, and one non-senior, or all four seniors.

$${}_{6}C_3 \cdot {}_{14}C_1 + {}_{6}C_4 = 295 \quad (11.39)$$

Example 11.44

How many five-letter word sequences consisting of 2 vowels and 3 consonants can be formed from the letters of the word INTRODUCE?

Solution

First we select a group of five letters consisting of 2 vowels and 3 consonants. Since there are 4 vowels and 5 consonants, we have

$${}_{4}C_2 \cdot {}_{5}C_3 \quad (11.40)$$

Since our next task is to make word sequences out of these letters, we multiply these by $5!$.

$${}_{4}C_2 \cdot {}_{5}C_3 \cdot 5! = 7200.$$

Example 11.45

A standard deck of playing cards has 52 cards consisting of 4 suits each with 13 cards. In how many different ways can a 5-card hand consisting of four cards of one suit and one of another be drawn?

Solution

We will do the problem using the following steps. Step 1. Select a suit. Step 2. Select four cards from this suit. Step 3. Select another suit. Step 4. Select a card from that suit.

Applying the multiplication axiom, we have

Ways of selecting a suit	Ways if selecting 4 cards from this suit	Ways if selecting the next suit	Ways of selecting a card from that suit
${}_{4}C_1$	${}_{13}C_4$	${}_{3}C_1$	${}_{13}C_1$

Table 11.13

$${}_{4}C_1 \cdot {}_{13}C_4 \cdot {}_{3}C_1 \cdot {}_{13}C_1 = 111,540. \quad (11.41)$$

Chapter 12

Sets and Counting: Homework¹

12.1 SETS AND COUNTING

Find the indicated sets.

Exercise 12.1

(Solution on p. 204.)

List all subsets of the following set.

$$\{\text{Al, Bob}\} \tag{12.1}$$

Exercise 12.2

List all subsets of the following set.

$$\{\text{Al, Bob, Chris}\} \tag{12.2}$$

Exercise 12.3

(Solution on p. 204.)

List the elements of the following set.

$$\{\text{Al, Bob, Chris, Dave}\} \cap \{\text{Bob, Chris, Dave, Ed}\} \tag{12.3}$$

Exercise 12.4

List the elements of the following set.

$$\{\text{Al, Bob, Chris, Dave}\} \cup \{\text{Bob, Chris, Dave, Ed}\} \tag{12.4}$$

In Problems 5 - 8, let Universal set = $U = \{a, b, c, d, e, f, g, h, i, j\}$, $V = \{a, e, i, f, h\}$, and $W = \{a, c, e, g, i\}$.

List the members of the following sets.

Exercise 12.5

(Solution on p. 204.)

$$V \cup W \tag{12.5}$$

¹This content is available online at <http://cnx.org/content/m38653/1.1/>.

Exercise 12.6

$$V \cap W \quad (12.6)$$

Exercise 12.7*(Solution on p. 204.)*

$$\overline{V \cup W} \quad (12.7)$$

Exercise 12.8

$$\overset{\Psi}{V} \cap \overset{\Psi}{W} \quad (12.8)$$

In 9 - 12, let Universal set = $U = \{1, 2, 3, 4, 5, 6, 7, 8, 9, 10\}$, $A = \{1, 2, 3, 4, 5\}$, $B = \{1, 3, 4, 6\}$, and $C = \{2, 4, 6\}$.

List the members of the following sets.

Exercise 12.9*(Solution on p. 204.)*

$$A \cup B \quad (12.9)$$

Exercise 12.10

$$A \cap C \quad (12.10)$$

Exercise 12.11*(Solution on p. 204.)*

$$\overline{A \cup B} \cap C \quad (12.11)$$

Exercise 12.12

$$\overset{\Psi}{\overline{A \cup B \cap C}} \quad (12.12)$$

Find the number of elements in the following sets.

Exercise 12.13*(Solution on p. 204.)*

In Mrs. Yamamoto's class of 35 students, 12 students are taking history, 18 are taking English, and 4 are taking both. Draw a Venn diagram and determine how many students are taking neither history nor English?

Exercise 12.14

In the County of Santa Clara 700,000 people read the San Jose Mercury News, 400,000 people read the San Francisco Examiner, and 100,000 read both newspapers. How many read either the Mercury News or the Examiner?

Exercise 12.15*(Solution on p. 204.)*

A survey of athletes revealed that for their minor aches and pains, 30 used aspirin, 50 used ibuprofen, and 15 used both. How many athletes were surveyed?

Exercise 12.16

In a survey of computer users, it was found that 50 use HP printers, 30 use IBM printers, 20 use Apple printers, 13 use HP and IBM, 9 use HP and Apple, 7 use IBM and Apple, and 3 use all three. How many use at least one of these Brands?

Exercise 12.17*(Solution on p. 204.)*

This quarter, a survey of 100 students at De Anza college finds that 50 take math, 40 take English, and 30 take history. Of these 15 take English and math, 10 take English and history, 10 take math and history, and 5 take all three subjects. Draw a Venn diagram and determine the following.

- The number of students taking math but not the other two subjects.
- The number of students taking English or math but not history.
- The number of students taking none of these subjects.

Exercise 12.18

In a survey of investors it was found that 100 invested in stocks, 60 in mutual funds, and 50 in bonds. Of these, 35 invested in stocks and mutual funds, 30 in mutual funds and bonds, 28 in stocks and bonds, and 20 in all three. Determine the following.

- The number of investors that participated in the survey.
- How many invested in stocks or mutual funds but not in bonds?
- How many invested in exactly one type of investment?

12.2 TREE DIAGRAMS AND THE MULTIPLICATION AXIOM

Do the following problems using a tree diagram or the multiplication axiom.

Exercise 12.19*(Solution on p. 204.)*

A man has 3 shirts, and 2 pairs of pants. Use a tree diagram to determine the number of possible outfits.

Exercise 12.20

In a city election, there are 2 candidates for mayor, and 3 for supervisor. Use a tree diagram to find the number of ways to fill the two offices.

Exercise 12.21*(Solution on p. 204.)*

There are 4 roads from Town A to Town B, 2 roads from Town B to Town C. Use a tree diagram to find the number of ways one can travel from Town A to Town C.

Exercise 12.22

Brown Home Construction offers a selection of 3 floor plans, 2 roof types, and 2 exterior wall types. Use a tree diagram to determine the number of possible homes available.

Exercise 12.23*(Solution on p. 204.)*

For lunch, a small restaurant offers 2 types of soups, three kinds of sandwiches, and two types of soft drinks. Use a tree diagram to determine the number of possible meals consisting of a soup, sandwich, and a soft drink.

Exercise 12.24

A California license plate consists of a number from 1 to 5, then three letters followed by three digits. How many such plates are possible?

Exercise 12.25*(Solution on p. 204.)*

A license plate consists of three letters followed by three digits. How many license plates are possible if no letter may be repeated?

Exercise 12.26

How many different 4-letter radio station call letters can be made if the first letter must be K or W and none of the letters may be repeated?

Exercise 12.27

(Solution on p. 204.)

How many seven-digit telephone numbers are possible if the first two digits cannot be ones or zeros?

Exercise 12.28

How many 3-letter word sequences can be formed using the letters $\{a, b, c, d\}$ if no letter is to be repeated?

Exercise 12.29

(Solution on p. 204.)

A family has two children, use a tree diagram to determine all four possibilities.

Exercise 12.30

A coin is tossed three times and the sequence of heads and tails is recorded. Use a tree diagram to determine the different possibilities.

Exercise 12.31

(Solution on p. 204.)

In how many ways can a 4-question true-false test be answered?

Exercise 12.32

In how many ways can three people be made to stand in a straight line?

Exercise 12.33

(Solution on p. 204.)

A combination lock is opened by first turning to the left, then to the right, and then to the left again. If there are 30 digits on the dial, how many possible combinations are there?

Exercise 12.34

How many different answers are possible for a multiple-choice test with 10 questions and five possible answers for each question?

12.3 PERMUTATIONS

Do the following problems using permutations.

Exercise 12.35

(Solution on p. 204.)

How many three-letter words can be made using the letters $\{a, b, c, d, e\}$ if no repetitions are allowed?

Exercise 12.36

A grocery store has five checkout counters, and seven clerks. How many different ways can the clerks be assigned to the counters?

Exercise 12.37

(Solution on p. 204.)

A group of fifteen people who are members of an investment club wish to choose a president, and a secretary. How many different ways can this be done?

Exercise 12.38

Compute the following.

- 9P_2
- 6P_4
- 8P_3
- 7P_4

Exercise 12.39 *(Solution on p. 204.)*

In how many ways can the letters of the word CUPERTINO be arranged if each letter is used only once in each arrangement?

Exercise 12.40

How many permutations of the letters of the word PROBLEM end in a vowel?

Exercise 12.41 *(Solution on p. 205.)*

How many permutations of the letters of the word SECURITY end in a consonant?

Exercise 12.42

How many permutations of the letters PRODUCT have consonants in the second and third positions?

Exercise 12.43 *(Solution on p. 205.)*

How many three-digit numbers are there?

Exercise 12.44

How many three-digit odd numbers are there?

Exercise 12.45 *(Solution on p. 205.)*

In how many different ways can five people be seated in a row if two of them insist on sitting next to each other?

Exercise 12.46

In how many different ways can five people be seated in a row if two of them insist on not sitting next to each other?

Exercise 12.47 *(Solution on p. 205.)*

In how many ways can 3 English, 3 history, and 2 math books be set on a shelf, if the English books are set on the left, history books in the middle, and math books on the right?

Exercise 12.48

In how many ways can 3 English, 3 history, and 2 math books be set on a shelf, if they are grouped by subject?

Exercise 12.49 *(Solution on p. 205.)*

You have 5 math books and 6 history books to put on a shelf with five slots. In how many ways can you put the books on the shelf if the first two slots are to be filled with math books and the next three with history books?

Exercise 12.50

You have 5 math books and 6 history books to put on a shelf with five slots. In how many ways can you put the books on the shelf if the first two slots are to be filled with the books of one subject and the next three slots are to be filled with the books of the other subject?

12.4 CIRCULAR PERMUTATIONS AND PERMUTATIONS WITH SIMILAR ELEMENTS

Do the following problems using the techniques learned in this section.

Exercise 12.51 *(Solution on p. 205.)*

In how many different ways can five children hold hands to play "Ring Around the Rosy"?

Exercise 12.52

In how many ways can three people be made to sit at a round table?

Exercise 12.53 *(Solution on p. 205.)*

In how many different ways can six children ride a "Merry Go Around" with six horses?

Exercise 12.54

In how many ways can three couples be seated at a round table, so that men and women sit alternately?

Exercise 12.55

(Solution on p. 205.)

In how many ways can six trinkets be arranged on a chain?

Exercise 12.56

In how many ways can five keys be put on a key ring?

Exercise 12.57

(Solution on p. 205.)

Find the number of different permutations of the letters of the word MASSACHUSETTS.

Exercise 12.58

Find the number of different permutations of the letters of the word MATHEMATICS.

Exercise 12.59

(Solution on p. 205.)

Seven flags, three red, two white, and two blue, are to be flown on seven poles. How many different arrangements are possible?

Exercise 12.60

How many different ways can three pennies, two nickels and five dimes be arranged in a row?

Exercise 12.61

(Solution on p. 205.)

How many four-digit numbers can be made using two 2's and two 3's?

Exercise 12.62

How many five-digit numbers can be made using two 6's and three 7's?

Exercise 12.63

(Solution on p. 205.)

If a coin is tossed 5 times, how many different outcomes of 3 heads, and 2 tails are possible?

Exercise 12.64

If a coin is tossed 10 times, how many different outcomes of 7 heads, and 3 tails are possible?

Exercise 12.65

(Solution on p. 205.)

If a team plays ten games, how many different outcomes of 6 wins, and 4 losses are possible?

Exercise 12.66

If a team plays ten games, how many different ways can the team have a winning season?

12.5 COMBINATIONS

Do the following problems using combinations.

Exercise 12.67

(Solution on p. 205.)

How many different 3-people committees can be chosen from ten people?

Exercise 12.68

How many different 5-player teams can be chosen from eight players?

Exercise 12.69

(Solution on p. 205.)

In how many ways can a person choose to vote for three out of five candidates on a ballot for a school board election?

Exercise 12.70

Compute the following:

- 9C_2
- 6C_4
- 8C_3
- 7C_4

Exercise 12.71 *(Solution on p. 205.)*

How many 5-card hands can be chosen from a deck of cards?

Exercise 12.72

How many 13-card bridge hands can be chosen from a deck of cards?

Exercise 12.73 *(Solution on p. 205.)*

There are twelve people at a party. If they all shake hands, how many different hand-shakes are there?

Exercise 12.74

In how many ways can a student choose to do four questions out of five on a test?

Exercise 12.75 *(Solution on p. 205.)*

Five points lie on a circle. How many chords can be drawn through them?

Exercise 12.76

How many diagonals does a hexagon have?

Exercise 12.77 *(Solution on p. 205.)*

There are five teams in a league. How many games are played if every team plays each other twice?

Exercise 12.78

A team plays 15 games a season. In how many ways can it have 8 wins and 7 losses?

Exercise 12.79 *(Solution on p. 205.)*

In how many different ways can a 4-child family have 2 boys and 2 girls?

Exercise 12.80

A coin is tossed five times. In how many ways can it fall three heads and two tails?

Exercise 12.81 *(Solution on p. 205.)*

The shopping area of a town is a square that is six blocks by six blocks. How many different routes can a taxi driver take to go from one corner of the shopping area to the opposite cater-corner?

Exercise 12.82

If the shopping area in Exercise 12.81 has a rectangular form of 5 blocks by 3 blocks, then how many different routes can a taxi driver take to drive from one end of the shopping area to the opposite kitty corner end?

12.6 COMBINATIONS INVOLVING SEVERAL SETS

Following problems involve combinations from several different sets.

Exercise 12.83 *(Solution on p. 205.)*

How many 5-person committees consisting of three boys and two girls can be chosen from a group of four boys and four girls?

Exercise 12.84

A club has 4 men, 5 women, 8 boys and 10 girls as members. In how many ways can a group of 2 men, 3 women, 4 boys and 4 girls be chosen?

Exercise 12.85 *(Solution on p. 205.)*

How many 4-person committees chosen from four men and six women will have at least three men?

Exercise 12.86

A batch contains 10 transistors of which three are defective. If three are chosen, in how many ways can one get two defective?

Exercise 12.87 *(Solution on p. 205.)*

In how many ways can five counters labeled A, B, C, D and E at a store be staffed by two men and three women chosen from a group of four men and six women?

Exercise 12.88

How many 4-letter word sequences consisting of two vowels and two consonants can be made from the letters of the word PHOENIX if no letter is repeated?

Three marbles are chosen from an urn that contains 5 red, 4 white, and 3 blue marbles. How many samples of the following type are possible?

Exercise 12.89

All three white.

(Solution on p. 205.)

Exercise 12.90

Two blue and one white.

Exercise 12.91

One of each color.

(Solution on p. 206.)

Exercise 12.92

All three of the same color.

Exercise 12.93

At least two red.

(Solution on p. 206.)

Exercise 12.94

None red.

Five coins are chosen from a bag that contains 4 dimes, 5 nickels, and 6 pennies. How many samples of five of the following type are possible?

Exercise 12.95

At least four nickels.

(Solution on p. 206.)

Exercise 12.96

No pennies.

Exercise 12.97

Five of a kind.

(Solution on p. 206.)

Exercise 12.98

Four of a kind.

Exercise 12.99

Two of one kind and two of another kind.

(Solution on p. 206.)

Exercise 12.100

Three of one kind and two of another kind.

Find the number of different ways to draw a 5-card hand from a deck to have the following combinations.

Exercise 12.101

Three face cards.

(Solution on p. 206.)

Exercise 12.102

A heart flush(all hearts).

Exercise 12.103

Two hearts and three diamonds.

(Solution on p. 206.)

Exercise 12.104

Two cards of one suit, and three of another suit.

Exercise 12.105

Two kings and three queens.

(Solution on p. 206.)

Exercise 12.106

Two cards of one value and three of another value.

12.7 BINOMIAL THEOREM

Use the Binomial Theorem to do the following problems.

Exercise 12.107 *(Solution on p. 206.)*

Expand $(a + b)^5$.

Exercise 12.108

Expand $(a - b)^6$.

Exercise 12.109 *(Solution on p. 206.)*

Expand $(x - 2y)^5$.

Exercise 12.110

Expand $(2x - 3y)^4$.

Exercise 12.111 *(Solution on p. 206.)*

Find the third term of $(2x - 3y)^6$.

Exercise 12.112

Find the sixth term of $(5x + y)^8$.

Exercise 12.113 *(Solution on p. 206.)*

Find the coefficient of the x^3y^4 term in the expansion of $(2x + y)^7$.

Exercise 12.114

Find the coefficient of the a^4b^6 term in the expansion of $(3a - b)^{10}$.

Exercise 12.115 *(Solution on p. 206.)*

A coin is tossed 5 times, in how many ways is it possible to get three heads and two tails?

Exercise 12.116

A coin is tossed 10 times, in how many ways is it possible to get seven heads and three tails?

Exercise 12.117 *(Solution on p. 206.)*

How many subsets are there of a set that has 6 elements?

Exercise 12.118

How many subsets are there of a set that has n elements?

12.8 CHAPTER REVIEW

Exercise 12.119 *(Solution on p. 206.)*

Suppose of the 4,000 freshmen at a college everyone is enrolled in a mathematics or an English class during a given quarter. If 2,000 are enrolled in a mathematics class, and 3,000 in an English class, how many are enrolled in both a mathematics class and an English class?

Exercise 12.120 *(Solution on p. 206.)*

In a survey of 250 people, it was found that 125 had read Time magazine, 175 had read Newsweek, 100 had read U. S. News, 75 had read Time and Newsweek, 60 had read Newsweek and U. S. News, 55 had read Time and U. S. News, and 25 had read all three.

- How many had read Time but not the other two?
- How many had read Time or Newsweek but not the U. S. News And World Report?
- How many had read none of these three magazines?

Exercise 12.121 *(Solution on p. 206.)*

At a manufacturing plant, a product goes through assembly, testing, and packing. If a plant has three assembly stations, two testing stations, and two packing stations, in how many different ways can a product achieve its completion?

Exercise 12.122 (Solution on p. 206.)

Six people are to line up for a photograph. How many different lineups are possible if three of them insist on standing next to each other ?

Exercise 12.123 (Solution on p. 206.)

How many four-letter word sequences can be made from the letters of the word CUPERTINO?

Exercise 12.124 (Solution on p. 206.)

In how many different ways can a 20-question multiple choice test be designed so that its answers contain 2 A's, 4 B's, 9 C's, 3 D's, and 2 E's?

Exercise 12.125 (Solution on p. 206.)

The U. S. Supreme Court has nine judges. In how many different ways can the judges cast a six-to-three decision in favor of a ruling?

Exercise 12.126 (Solution on p. 206.)

In how many different ways can a coach choose a linebacker, a guard, and a tackle from five players on the bench, if all five can play any of the three positions?

Exercise 12.127 (Solution on p. 207.)

How many three digit even numbers can be formed from the digits 1, 2, 3, 4, 5 if no repetitions are allowed?

Exercise 12.128 (Solution on p. 207.)

Compute:

- a. 9C_4
- b. 8P_3
- c. $\frac{10!}{4!(10-4)!}$

Exercise 12.129 (Solution on p. 207.)

In how many ways can 3 English, 3 Math, and 4 Spanish books be set on a shelf if the books are grouped by subject?

Exercise 12.130 (Solution on p. 207.)

In how many ways can a 10-question multiple choice test with four possible answers for each question be answered?

Exercise 12.131 (Solution on p. 207.)

On a soccer team three fullbacks can play any of the three fullback positions, left, center, and right. The three halfbacks can play any of the three halfback positions, the four forwards can play any of the four positions, and the goalkeeper plays only his position. How many different arrangements of the 11 players are possible?

Exercise 12.132 (Solution on p. 207.)

From a group of 6 people, 3 are assigned to cleaning, 2 to hauling and one to garbage collecting. How many different ways can this be done?

Exercise 12.133 (Solution on p. 207.)

How many three-letter word sequences can be made from the letters of the word OXYGEN?

Exercise 12.134 (Solution on p. 207.)

In how many ways can 3 books be selected from 4 English and 2 History books if at least one English book must be chosen?

Exercise 12.135 (Solution on p. 207.)

Five points lie on the rim of a circle. Choosing the points as vertices, how many different triangles can be drawn?

Exercise 12.136 (Solution on p. 207.)

A club consists of six men and nine women. In how many ways can a president, a vice president and a treasurer be chosen if the two of the officers must be women?

Exercise 12.137 (Solution on p. 207.)

Of its 12 sales people, a company wants to assign 4 to its Western territory, 5 to its Northern territory, and 3 to its Southern territory. How many ways can this be done?

Exercise 12.138 (Solution on p. 207.)

How many permutations of the letters of the word OUTSIDE have consonants in the first and last place?

Exercise 12.139 (Solution on p. 207.)

How many distinguishable permutations are there in the word COMMUNICATION?

Exercise 12.140 (Solution on p. 207.)

How many five-card poker hands consisting of the following distribution are there?

- A flush(all five cards of a single suit)
- Three of a kind(e.g. three aces and two other cards)
- Two pairs(e.g. two aces, two kings and one other card)
- A straight(all five cards in a sequence)

Exercise 12.141 (Solution on p. 207.)

Company stocks on an exchange are given symbols consisting of three letters. How many different three-letter symbols are possible?

Exercise 12.142 (Solution on p. 207.)

How many four-digit odd numbers are there?

Exercise 12.143 (Solution on p. 207.)

In how many ways can 7 people be made to stand in a straight line? In a circle?

Exercise 12.144 (Solution on p. 207.)

A united nations delegation consists of 6 Americans, 5 Russians, and 4 Chinese. Answer the following questions.

- How many committees of five people are there?
- How many committees of three people consisting of at least one American are there?
- How many committees of four people having no Russians are there?
- How many committees of three people have more Americans than Russians?
- How many committees of three people do not have all three Americans?

Exercise 12.145 (Solution on p. 208.)

If a coin is flipped five times, in how many different ways can it show up three heads?

Exercise 12.146 (Solution on p. 208.)

To reach his destination, a man is to walk three blocks north and four blocks west. How many different routes are possible?

Exercise 12.147 (Solution on p. 208.)

All three players of the women's beach volleyball team, and all three players of the men's beach volleyball team are to line up for a picture with all members of the women's team lined together and all members of men's team lined up together. How many ways can this be done?

Exercise 12.148 (Solution on p. 208.)

From a group of 6 Americans, 5 Japanese and 4 German delegates, two Americans, two Japanese and a German are chosen to line up for a photograph. In how many different ways can this be done?

Exercise 12.149 (Solution on p. 208.)

Find the fourth term of the expansion $(2x - 3y)^8$.

Exercise 12.150 (Solution on p. 208.)

Find the coefficient of the a^5b^4 term in the expansion of $(a - 2b)^9$.

Solutions to Exercises in Chapter 12

Solutions to Sets and Counting: Homework

Solution to Exercise 12.1 (p. 193)

$$\{\text{Al, Bob}\}, \{\text{Al}\}, \{\text{Bob}\}, \quad (12.13)$$

Solution to Exercise 12.3 (p. 193)

$$\{\text{Bob, Chris, Dave}\} \quad (12.14)$$

Solution to Exercise 12.5 (p. 193)

$$\{a, e, i, f, h, c, g\} \quad (12.15)$$

Solution to Exercise 12.7 (p. 194)

$$\{b, d, j\} \quad (12.16)$$

Solution to Exercise 12.9 (p. 194)

$$\{1, 2, 3, 4, 5, 6\} \quad (12.17)$$

Solution to Exercise 12.11 (p. 194)

\emptyset

Solution to Exercise 12.13 (p. 194)

9 students

Solution to Exercise 12.15 (p. 194)

65

Solution to Exercise 12.17 (p. 195)

- a. 30
- b. 60
- c. 10

Solution to Exercise 12.19 (p. 195)

6

Solution to Exercise 12.21 (p. 195)

8

Solution to Exercise 12.23 (p. 195)

12

Solution to Exercise 12.25 (p. 195)

15,600,000

Solution to Exercise 12.27 (p. 196)

6,400,000

Solution to Exercise 12.29 (p. 196)

BB, BG, GB, GG

Solution to Exercise 12.31 (p. 196)

16

Solution to Exercise 12.33 (p. 196)

27,000

Solution to Exercise 12.35 (p. 196)

60

Solution to Exercise 12.37 (p. 196)

210

- Solution to Exercise 12.39 (p. 197)**
362,880
- Solution to Exercise 12.41 (p. 197)**
25,200
- Solution to Exercise 12.43 (p. 197)**
900
- Solution to Exercise 12.45 (p. 197)**
48
- Solution to Exercise 12.47 (p. 197)**
72
- Solution to Exercise 12.49 (p. 197)**
2,400
- Solution to Exercise 12.51 (p. 197)**
24
- Solution to Exercise 12.53 (p. 197)**
120
- Solution to Exercise 12.55 (p. 198)**
120
- Solution to Exercise 12.57 (p. 198)**
64,864,800
- Solution to Exercise 12.59 (p. 198)**
210
- Solution to Exercise 12.61 (p. 198)**
6
- Solution to Exercise 12.63 (p. 198)**
10
- Solution to Exercise 12.65 (p. 198)**
210
- Solution to Exercise 12.67 (p. 198)**
120
- Solution to Exercise 12.69 (p. 198)**
10
- Solution to Exercise 12.71 (p. 199)**
2,598,960
- Solution to Exercise 12.73 (p. 199)**
66
- Solution to Exercise 12.75 (p. 199)**
10
- Solution to Exercise 12.77 (p. 199)**
20
- Solution to Exercise 12.79 (p. 199)**
6
- Solution to Exercise 12.81 (p. 199)**
924
- Solution to Exercise 12.83 (p. 199)**
24
- Solution to Exercise 12.85 (p. 199)**
25
- Solution to Exercise 12.87 (p. 199)**
14,400

Solution to Exercise 12.89 (p. 200)

4

Solution to Exercise 12.91 (p. 200)

60

Solution to Exercise 12.93 (p. 200)

80

Solution to Exercise 12.95 (p. 200)

51

Solution to Exercise 12.97 (p. 200)

7

Solution to Exercise 12.99 (p. 200)

1,410

Solution to Exercise 12.101 (p. 200)

171,600

Solution to Exercise 12.103 (p. 200)

22,308

Solution to Exercise 12.105 (p. 200)

24

Solution to Exercise 12.107 (p. 201)

$$a^5 + 5a^4b + 10a^3b^2 + 10a^2b^3 + 5ab^4 + b^5 \quad (12.18)$$

Solution to Exercise 12.109 (p. 201)

$$x^5 - 10x^4y + 40x^3y^2 - 80x^2y^3 + 80xy^4 - 32y^5 \quad (12.19)$$

Solution to Exercise 12.111 (p. 201)

$$2160x^4y^2 \quad (12.20)$$

Solution to Exercise 12.113 (p. 201)

280

Solution to Exercise 12.115 (p. 201)

10

Solution to Exercise 12.117 (p. 201)

64

Solution to Exercise 12.119 (p. 201)

1,000

Solution to Exercise 12.120 (p. 201)

a. 20

b. 135

c. 15

Solution to Exercise 12.121 (p. 201)

12

Solution to Exercise 12.122 (p. 202)

144

Solution to Exercise 12.123 (p. 202)

3,024

Solution to Exercise 12.124 (p. 202)

11,639,628,000

Solution to Exercise 12.125 (p. 202)

84

Solution to Exercise 12.126 (p. 202)

60

Solution to Exercise 12.127 (p. 202)

24

Solution to Exercise 12.128 (p. 202)

a. 126

b. 336

c. 210

Solution to Exercise 12.129 (p. 202)

5,184

Solution to Exercise 12.130 (p. 202)

1,048,576

Solution to Exercise 12.131 (p. 202)

46,200

Solution to Exercise 12.132 (p. 202)

60

Solution to Exercise 12.133 (p. 202)

120

Solution to Exercise 12.134 (p. 202)

20

Solution to Exercise 12.135 (p. 202)

10

Solution to Exercise 12.136 (p. 202)

1296

Solution to Exercise 12.137 (p. 203)

27,720

Solution to Exercise 12.138 (p. 203)

720

Solution to Exercise 12.139 (p. 203)

194,594,400

Solution to Exercise 12.140 (p. 203)

a. 5148

b. 58,656

c. 123,552

d. 10,240 or 9216

Solution to Exercise 12.141 (p. 203)

17,576

Solution to Exercise 12.142 (p. 203)

4500

Solution to Exercise 12.143 (p. 203)

5040; 720

Solution to Exercise 12.144 (p. 203)

a. 3003

b. 371

c. 210

d. 191

e. 435

Solution to Exercise 12.145 (p. 203)

10

Solution to Exercise 12.146 (p. 203)

35

Solution to Exercise 12.147 (p. 203)

72

Solution to Exercise 12.148 (p. 203)

72,000

Solution to Exercise 12.149 (p. 203)

$$-48384x^5y^3 \quad (12.21)$$

Solution to Exercise 12.150 (p. 203)

$$2016a^5b^4 \quad (12.22)$$

Chapter 13

Probability¹

13.1 Chapter Overview

In this chapter, you will learn to:

1. Write sample spaces.
2. Determine whether two events are mutually exclusive.
3. Use the Addition Rule.
4. Calculate probabilities using both tree diagrams and combinations.
5. Do problems involving conditional probability.
6. Determine whether two events are independent.

13.2 Sample Spaces and Probability

If two coins are tossed, what is the probability that both coins will fall heads? The problem seems simple enough, but it is not uncommon to hear the incorrect answer $1/3$. A student may incorrectly reason that if two coins are tossed there are three possibilities, one head, two heads, or no heads. Therefore, the probability of two heads is one out of three. The answer is wrong because if we toss two coins there are four possibilities and not three. For clarity, assume that one coin is a penny and the other a nickel. Then we have the following four possibilities.

HH HT TH TT

The possibility HT, for example, indicates a head on the penny and a tail on the nickel, while TH represents a tail on the penny and a head on the nickel.

It is for this reason, we emphasize the need for understanding sample spaces.

An act of flipping coins, rolling dice, drawing cards, or surveying people are referred to as an **experiment**.

Definition 13.1: Sample Spaces

A sample space of an experiment is the set of all possible outcomes.

Example 13.1

If a die is rolled, write a sample space.

Solution

A die has six faces each having an equally likely chance of appearing. Therefore, the set of all possible outcomes S is

$\{1, 2, 3, 4, 5, 6\}$.

¹This content is available online at <http://cnx.org/content/m18907/1.2/>.

Example 13.2

A family has three children. Write a sample space.

Solution

The sample space consists of eight possibilities.

$$\{BBB, BBG, BGB, BGG, GBB, GBG, GGB, GGG\} \quad (13.1)$$

The possibility BGB, for example, indicates that the first born is a boy, the second born a girl, and the third a boy.

We illustrate these possibilities with a tree diagram.

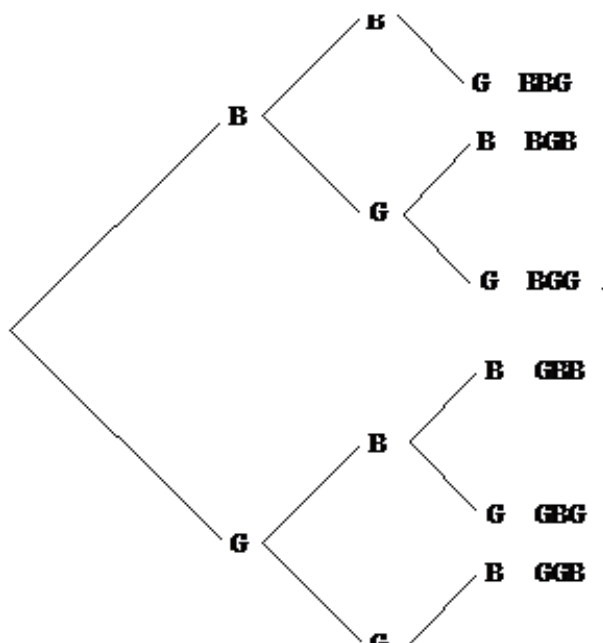

Figure 13.1

Example 13.3

Two dice are rolled. Write the sample space.

Solution

We assume one of the dice is red, and the other green. We have the following 36 possibilities.

	Green					
Red	1	2	3	4	5	6
1	(1,1)	(1,2)	(1,3)	(1,4)	(1,5)	(1,6)
2	(2,1)	(2,2)	(2,3)	(2,4)	(2,5)	(2,6)
3	(3,1)	(3,2)	(3,3)	(3,4)	(3,5)	(3,6)
4	(4,1)	(4,2)	(4,3)	(4,4)	(4,5)	(4,6)
5	(5,1)	(5,2)	(5,3)	(5,4)	(5,5)	(5,6)
6	(6,1)	(6,2)	(6,3)	(6,4)	(6,5)	(6,6)

Table 13.1

The entry (2, 5), for example, indicates that the red die shows a two, and the green a 5.

Now that we understand the concept of a sample space, we will define probability.

Probability

For a sample space S , and an outcome A of S , the following two properties are satisfied.

1. If A is an outcome of a sample space, then the probability of A , denoted by $P(A)$, is between 0 and 1, inclusive.

$$0 \leq P(A) \leq 1 \quad (13.2)$$

2. The sum of the probabilities of all the outcomes in S equals 1.

Example 13.4

If two dice, one red and one green, are rolled, find the probability that the red die shows a 3 and the green shows a six.

Solution

Since two dice are rolled, there are 36 possibilities. The probability of each outcome, listed in Example 13.3, is equally likely.

Since (3, 6) is one such outcome, the probability of obtaining (3, 6) is $1/36$.

The example we just considered consisted of only one outcome of the sample space. We are often interested in finding probabilities of several outcomes represented by an event.

An **event** is a subset of a sample space. If an event consists of only one outcome, it is called a **simple event**.

Example 13.5

If two dice are rolled, find the probability that the sum of the faces of the dice is 7.

Solution

Let E represent the event that the sum of the faces of two dice is 7.

Since the possible cases for the sum to be 7 are: (1, 6), (2, 5), (3, 4), (4, 3), (5, 2), and (6, 1).

$$E = \{(1, 6), (2, 5), (3, 4), (4, 3), (5, 2), \text{ and } (6, 1)\} \quad (13.3)$$

and the probability of the event E ,

$$P(E) = 6/36 \text{ or } 1/6.$$

Example 13.6

A jar contains 3 red, 4 white, and 3 blue marbles. If a marble is chosen at random, what is the probability that the marble is a red marble or a blue marble?

Solution

We assume the marbles are $r_1, r_2, r_3, w_1, w_2, w_3, w_4, b_1, b_2, b_3$. Let the event C represent that the marble is red or blue.

The sample space $S = \{r_1, r_2, r_3, w_1, w_2, w_3, w_4, b_1, b_2, b_3\}$

And the event $C = \{r_1, r_2, r_3, b_1, b_2, b_3\}$

Therefore, the probability of C ,

$$P(C) = 6/10 \text{ or } 3/5.$$

Example 13.7

A jar contains three marbles numbered 1, 2, and 3. If two marbles are drawn, what is the probability that the sum of the numbers is 4?

Solution

Since two marbles are drawn, the sample space consists of the following six possibilities.

$$S = \{(1, 2), (1, 3), (2, 3), (2, 1), (3, 1), (3, 2)\} \quad (13.4)$$

Let the event F represent that the sum of the numbers is four. Then

$$F = \{(1, 3), (3, 1)\} \quad (13.5)$$

Therefore, the probability of F is

$$P(F) = 2/6 \text{ or } 1/3.$$

Example 13.8

A jar contains three marbles numbered 1, 2, and 3. If two marbles are drawn, what is the probability that the sum of the numbers is *at least* 4?

Solution

The sample space, as in Example 13.7, consists of the following six possibilities.

$$S = \{(1, 2), (1, 3), (2, 3), (2, 1), (3, 1), (3, 2)\} \quad (13.6)$$

Let the event A represent that the sum of the numbers is at least four. Then

$$F = \{(1, 3), (3, 1), (2, 3), (3, 2)\} \quad (13.7)$$

Therefore, the probability of F is

$$P(F) = 4/6 \text{ or } 2/3.$$

13.3 Mutually Exclusive Events and the Addition Rule

In the Chapter 11, we learned to find the union, intersection, and complement of a set. We will now use these set operations to describe events.

The **union** of two events E and F , $E \cup F$, is the set of outcomes that are in E or in F or in both.

The **intersection** of two events E and F , $E \cap F$, is the set of outcomes that are in both E and F .

The **complement** of an event E , denoted by E^c , is the set of outcomes in the sample space S that are not in E . It is worth noting that $P(E^c) = 1 - P(E)$. This follows from the fact that if the sample space has n elements and E has k elements, then E^c has $n - k$ elements. Therefore,

$$P(E^c) = \frac{n-k}{n} = 1 - \frac{k}{n} = 1 - P(E).$$

Of particular interest to us are the events whose outcomes do not overlap. We call these events mutually exclusive.

Two events E and F are said to be **mutually exclusive** if they do not intersect. That is, $E \cap F = \emptyset$.

Next we'll determine whether a given pair of events are mutually exclusive.

Example 13.9

A card is drawn from a standard deck. Determine whether the pair of events given below is mutually exclusive.

$$E = \{\text{The card drawn is an Ace}\} \quad (13.8)$$

$$F = \{\text{The card drawn is a heart}\} \quad (13.9)$$

Solution

Clearly the ace of hearts belongs to both sets. That is

$$E \cap F = \{\text{Ace of hearts}\} \neq \emptyset.$$

Therefore, the events E and F are not mutually exclusive.

Example 13.10

Two dice are rolled. Determine whether the pair of events given below is mutually exclusive.

$$G = \{\text{The sum of the faces is six}\} \quad (13.10)$$

$$H = \{\text{One die shows a four}\} \quad (13.11)$$

Solution

For clarity, we list the elements of both sets.

$$G = \{(1, 5), (2, 4), (3, 3), (4, 2), (5, 1)\} \quad (13.12)$$

$$H = \{(2, 4), (4, 2)\} \quad (13.13)$$

Clearly, $G \cap H = \{(2, 4), (4, 2)\} \neq \emptyset$.

Therefore, the two sets are not mutually exclusive.

Example 13.11

A family has three children. Determine whether the following pair of events are mutually exclusive.

$$M = \{\text{The family has at least one boy}\} \quad (13.14)$$

$$N = \{\text{The family has all girls}\} \quad (13.15)$$

Solution

Although the answer may be clear, we list both the sets.

$M = \{\text{BBB, BBG, BGB, BGG, GBB, GBG, GGB}\}$ and $N = \{\text{GGG}\}$

Clearly, $M \cap N = \emptyset$

Therefore, the events M and N are mutually exclusive.

We will now consider problems that involve the union of two events.

Example 13.12

If a die is rolled, what is the probability of obtaining an even number or a number greater than four?

Solution

Let E be the event that the number shown on the die is an even number, and let F be the event that the number shown is greater than four.

The sample space $S = \{1, 2, 3, 4, 5, 6\}$. The event $E = \{2, 4, 6\}$, and the event $F = \{5, 6\}$

We need to find $P(E \cup F)$.

Since $P(E) = 3/6$, and $P(F) = 2/6$, a student may say $P(E \cup F) = 3/6 + 2/6$. This will be incorrect because the element 6, which is in both E and F has been counted twice, once as an element of E and once as an element of F . In other words, the set $E \cup F$ has only four elements and not five. Therefore, $P(E \cup F) = 4/6$ and not $5/6$.

This can be illustrated by a Venn diagram.

The sample space S , the events E and F , and $E \cap F$ are listed below.

$S = \{1, 2, 3, 4, 5, 6\}$, $E = \{2, 4, 6\}$, $F = \{5, 6\}$, and $E \cap F = \{6\}$.

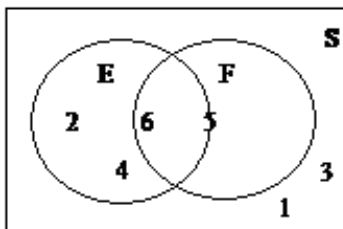

Figure 13.2

The above figure shows S , E , F , and $E \cap F$.

Finding the probability of $E \cup F$, is the same as finding the probability that E will happen, or F will happen, or both will happen. If we count the number of elements $n(E)$ in E , and add to it the number of elements $n(F)$ in F , the points in both E and F are counted twice, once as

elements of E and once as elements of F . Now if we subtract from the sum, $n(E) + n(F)$, the number $n(E \cap F)$, we remove the duplicity and get the correct answer. So as a rule,

$$n(E \cup F) = n(E) + n(F) - n(E \cap F) \quad (13.16)$$

By dividing the entire equation by $n(S)$, we get

$$\frac{n(E \cup F)}{n(S)} = \frac{n(E)}{n(S)} + \frac{n(F)}{n(S)} - \frac{n(E \cap F)}{n(S)} \quad (13.17)$$

Since the probability of an event is the number of elements in that event divided by the number of all possible outcomes, we have

$$P(E \cup F) = P(E) + P(F) - P(E \cap F) \quad (13.18)$$

Applying the above for this example, we get

$$P(E \cup F) = 3/6 + 2/6 - 1/6 = 4/6 \quad (13.19)$$

This is because, when we add $P(E)$ and $P(F)$, we have added $P(E \cap F)$ twice. Therefore, we must subtract $P(E \cap F)$, once.

This gives us the general formula, called the **Addition Rule**, for finding the probability of the union of two events. It states

$$P(E \cup F) = P(E) + P(F) - P(E \cap F) \quad (13.20)$$

If two events E and F are mutually exclusive, then $E \cap F = \emptyset$ and $P(E \cap F) = 0$, and we get

$$P(E \cup F) = P(E) + P(F) \quad (13.21)$$

Example 13.13

If a card is drawn from a deck, use the addition rule to find the probability of obtaining an ace or a heart.

Solution

Let A be the event that the card is an ace, and H the event that it is a heart.

Since there are four aces, and thirteen hearts in the deck, $P(A) = 4/52$ and $P(H) = 13/52$. Furthermore, since the intersection of two events is an ace of hearts, $P(A \cap H) = 1/52$

We need to find $P(A \cup H)$.

$$P(A \cup H) = P(A) + P(H) - P(A \cap H) = 4/52 + 13/52 - 1/52 = 16/52.$$

Example 13.14

Two dice are rolled, and the events F and T are as follows:

$F = \{\text{The sum of the dice is four}\}$ and $T = \{\text{At least one die shows a three}\}$

Find $P(F \cup T)$.

Solution

We list F and T , and $F \cap T$ as follows:

$$F = \{(1, 3), (2, 2), (3, 1)\} \quad (13.22)$$

$$T = \{(3, 1), (3, 2), (3, 3), (3, 4), (3, 5), (3, 6), (1, 3), (2, 3), (4, 3), (5, 3), (6, 3)\} \quad (13.23)$$

$$F \cap T = \{(1, 3), (3, 1)\} \quad (13.24)$$

Since $P(F \cup T) = P(F) + P(T) - P(F \cap T)$

We have $P(F \cup T) = 3/36 + 11/36 - 2/36 = 12/36$.

Example 13.15

Mr. Washington is seeking a mathematics instructor's position at his favorite community college in Cupertino. His employment depends on two conditions: whether the board approves the position, and whether the hiring committee selects him. There is a 80% chance that the board will approve the position, and there is a 70% chance that the hiring committee will select him. If there is a 90% chance that at least one of the two conditions, the board approval or his selection, will be met, what is the probability that Mr. Washington will be hired?

Solution

Let A be the event that the board approves the position, and S be the event that Mr. Washington gets selected. We have,

$P(A) = .80$, $P(S) = .70$, and $P(A \cup S) = .90$.

We need to find, $P(A \cap S)$.

The addition formula states that,

$$P(A \cup S) = P(A) + P(S) - P(A \cap S) \quad (13.25)$$

Substituting the known values, we get

$$.90 = .80 + .70 - P(A \cap S) \quad (13.26)$$

Therefore, $P(A \cap S) = .60$.

Example 13.16

The probability that this weekend will be cold is .6, the probability that it will be rainy is .7, and probability that it will be both cold and rainy is .5. What is the probability that it will be neither cold nor rainy?

Solution

Let C be the event that the weekend will be cold, and R be event that it will be rainy. We are given that

$P(C) = .6$, $P(R) = .7$, $P(C \cap R) = .5$

$$P(C \cup R) = P(C) + P(R) - P(C \cap R) = .6 + .7 - .5 = .8 \quad (13.27)$$

We want to find $P((C \cup R)^c)$.

$$P((C \cup R)^c) = 1 - P(C \cup R) = 1 - .8 = .2 \quad (13.28)$$

We summarize this section by listing the important rules.

13.17

The Addition Rule

For Two Events E and F , $P(E \cup F) = P(E) + P(F) - P(E \cap F)$

The Addition Rule for Mutually Exclusive Events

If Two Events E and F are Mutually Exclusive, then $P(E \cup F) = P(E) + P(F)$

The Complement Rule

If E^c is the Complement of Event E , then $P(E^c) = 1 - P(E)$

13.4 Probability Using Tree Diagrams and Combinations

In this section, we will apply previously learnt counting techniques in calculating probabilities, and use tree diagrams to help us gain a better understanding of what is involved.

We begin with an example.

Example 13.18

Suppose a jar contains 3 red and 4 white marbles. If two marbles are drawn with replacement, what is the probability that both marbles are red?

Solution

Let E be the event that the first marble drawn is red, and let F be the event that the second marble drawn is red.

We need to find $P(E \cap F)$.

By the statement, "two marbles are drawn with replacement," we mean that the first marble is replaced before the second marble is drawn.

There are 7 choices for the first draw. And since the first marble is replaced before the second is drawn, there are, again, seven choices for the second draw. Using the multiplication axiom, we conclude that the sample space S consists of 49 ordered pairs. Of the 49 ordered pairs, there are $3 \times 3 = 9$ ordered pairs that show red on the first draw and, also, red on the second draw. Therefore,

$$P(E \cap F) = \frac{9}{49} = \frac{3}{7} \cdot \frac{3}{7} \quad (13.29)$$

Further note that in this particular case

$$P(E \cap F) = P(E) \cdot P(F) \quad (13.30)$$

Example 13.19

If in the Example 13.18, the two marbles are drawn without replacement, then what is the probability that both marbles are red?

Solution

By the statement, "two marbles are drawn without replacement," we mean that the first marble is not replaced before the second marble is drawn.

Again, we need to find $P(E \cap F)$.

There are, again, 7 choices for the first draw. And since the first marble is not replaced before the second is drawn, there are only six choices for the second draw. Using the multiplication axiom,

we conclude that the sample space S consists of 42 ordered pairs. Of the 42 ordered pairs, there are $3 \times 2 = 6$ ordered pairs that show red on the first draw and red on the second draw. Therefore,

$$P(E \cap F) = \frac{6}{42} = \frac{3}{7} \cdot \frac{2}{6} \quad (13.31)$$

Here $3/7$ represents $P(E)$, and $2/6$ represents the probability of drawing a red on the second draw, given that the first draw resulted in a red. We write the latter as $P(\text{Red on the second} \mid \text{red on first})$ or $P(F \mid E)$. The " \mid " represents the word "given." Therefore,

$$P(E \cap F) = P(E) \cdot P(F \mid E) \quad (13.32)$$

The above result is an important one and will appear again in later sections.

We now demonstrate the above results with a tree diagram.

Example 13.20

Suppose a jar contains 3 red and 4 white marbles. If two marbles are drawn without replacement, find the following probabilities using a tree diagram.

- The probability that both marbles are white.
- The probability that the first marble is red and the second white.
- The probability that one marble is red and the other white.

Solution

Let R be the event that the marble drawn is red, and let W be the event that the marble drawn is white.

We draw the following tree diagram.

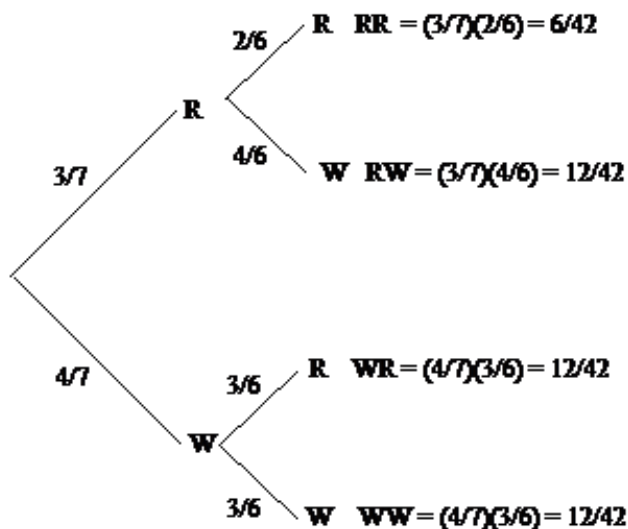

Figure 13.3

Although the tree diagrams give us better insight into a problem, they are not practical for problems where more than two or three things are chosen. In such cases, we use the concept of combinations that we learned in Chapter 11. This method is best suited for problems where the order in which the objects are chosen is not important, and the objects are chosen without replacement.

Example 13.21

Suppose a jar contains 3 red, 2 white, and 3 blue marbles. If three marbles are drawn without replacement, find the following probabilities.

- P (Two red and one white)
- P (One of each color)
- P (None blue)
- P (At least one blue)

Solution

Let us suppose the marbles are labeled as $R_1, R_2, R_3, W_1, W_2, B_1, B_2, B_3$.

- P (Two red and one white)

We analyze the problem in the following manner.

Since we are choosing 3 marbles from a total of 8, there are $8C3 = 56$ possible combinations. Of these 56 combinations, there are $3C2 \times 2C1 = 6$ combinations consisting of 2 red and one white. Therefore,

$$P(\text{Two red and one white}) = \frac{3C2 \times 2C1}{8C3} = \frac{6}{56}.$$

- P (One of each color)

Again, there are $8C3 = 56$ possible combinations. Of these 56 combinations, there are $3C1 \times 2C1 \times 3C1 = 18$ combinations consisting of one red, one white, and one blue. Therefore,

$$P(\text{One of each color}) = \frac{3C1 \times 2C1 \times 3C1}{8C3} = \frac{18}{56}.$$

- P (None blue)

There are 5 non-blue marbles, therefore

$$P(\text{None blue}) = \frac{5C3}{8C3} = \frac{10}{56} = \frac{5}{28}.$$

- P (At least one blue)

By "at least one blue marble," we mean the following: one blue marble and two non-blue marbles, or two blue marbles and one non-blue marble, or all three blue marbles. So we have to find the sum of the probabilities of all three cases.

$$P(\text{At least one blue}) = P(\text{one blue, two non-blue}) + P(\text{two blue, one non-blue}) + P(\text{three blue}) \quad (13.33)$$

$$P(\text{At least one blue}) = \frac{3C1 \times 5C2}{8C3} + \frac{3C2 \times 5C1}{8C3} + \frac{3C3}{8C3} \quad (13.34)$$

$$P(\text{At least one blue}) = 30/56 + 15/56 + 1/56 = 46/56 = 23/28.$$

Alternately,

we use the fact that $P(E) = 1 - P(E^c)$.

If the event $E = \text{At least one blue}$, then $E^c = \text{None blue}$.

But from part c of this example, we have $P(E^c) = 5/28$

Therefore, $P(E) = 1 - 5/28 = 23/28$.

Example 13.22

Five cards are drawn from a deck. Find the probability of obtaining two pairs, that is, two cards of one value, two of another value, and one other card.

Solution

Let us first do an easier problem—the probability of obtaining a pair of kings and queens.

Since there are four kings, and four queens in the deck, the probability of obtaining two kings, two queens and one other card is

$$P(\text{A pair of kings and queens}) = \frac{4C2 \times 4C2 \times 44C1}{52C5} \quad (13.35)$$

To find the probability of obtaining two pairs, we have to consider all possible pairs.

Since there are altogether 13 values, that is, aces, deuces, and so on, there are $13C2$ different combinations of pairs.

$$P(\text{Two pairs}) = 13C2 \cdot \frac{4C2 \times 4C2 \times 44C1}{52C5} = .04754 \quad (13.36)$$

We end the section by solving a problem called the **Birthday Problem**.

Example 13.23

If there are 25 people in a room, what is the probability that at least two people have the same birthday?

Solution

Let event E represent that at least two people have the same birthday.

We first find the probability that no two people have the same birthday.

We analyze as follows.

Suppose there are 365 days to every year. According to the multiplication axiom, there are 365^{25} possible birthdays for 25 people. Therefore, the sample space has 365^{25} elements. We are interested in the probability that no two people have the same birthday. There are 365 possible choices for the first person and since the second person must have a different birthday, there are 364 choices for the second, 363 for the third, and so on. Therefore,

$$P(\text{No two have the same birthday}) = \frac{365 \cdot 364 \cdot 363 \cdots 341}{365^{25}} = \frac{365P25}{365^{25}} \quad (13.37)$$

Since $P(\text{at least two people have the same birthday}) = 1 - P(\text{No two have the same birthday})$,

$$P(\text{at least two people have the same birthday}) = 1 - \frac{365P25}{365^{25}} = .5687 \quad (13.38)$$

13.5 Conditional Probability

Suppose you and a friend wish to play a game that involves choosing a single card from a well-shuffled deck. Your friend deals you one card, face down, from the deck and offers you the following deal: If the card is a king, he will pay you \$5, otherwise, you pay him \$1. Should you play the game?

You reason in the following manner. Since there are four kings in the deck, the probability of obtaining a king is $4/52$ or $1/13$. And, probability of not obtaining a king is $12/13$. This implies that the ratio of your winning to losing is 1 to 12, while the payoff ratio is only \$1 to \$5. Therefore, you determine that you should not play.

Now consider the following scenario. While your friend was dealing the card, you happened to get a glance of it and noticed that the card was a face card. Should you, now, play the game?

Since there are 12 face cards in the deck, the total elements in the sample space are no longer 52, but just 12. This means the chance of obtaining a king is $4/12$ or $1/3$. So your chance of winning is $1/3$ and of losing $2/3$. This makes your winning to losing ratio 1 to 2 which fares much better with the payoff ratio of \$1 to \$5. This time, you determine that you should play.

In the second part of the above example, we were finding the probability of obtaining a king knowing that a face card had shown. This is an example of **conditional probability**. Whenever we are finding the probability of an event E under the condition that another event F has happened, we are finding conditional probability.

The symbol $P(E | F)$ denotes the problem of finding the probability of E given that F has occurred. We read $P(E | F)$ as "the probability of E , given F ."

Example 13.24

A family has three children. Find the conditional probability of having two boys and a girl given that the first born is a boy.

Solution

Let event E be that the family has two boys and a girl, and F the event that the first born is a boy.

First, we list the sample space for a family of three children as follows.

$$S = \{BBB, BBG, BGB, BGG, GBB, GBG, GGB, GGG\} \quad (13.39)$$

Since we know that the first born is a boy, our possibilities narrow down to four outcomes, BBB, BBG, BGB, and BGG.

Among the four, BBG and BGB represent two boys and a girl.

Therefore, $P(E | F) = 2/4$ or $1/2$.

Let us now develop a formula for the conditional probability $P(E | F)$.

Suppose an experiment consists of n equally likely events. Further suppose that there are m elements in F , and c elements in $E \cap F$, as shown in the following Venn diagram.

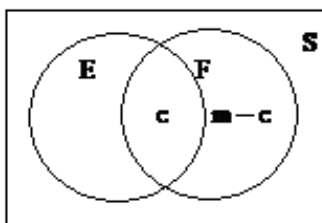

Figure 13.4

If the event F has occurred, the set of all possible outcomes is no longer the entire sample space, but instead, the subset F . Therefore, we only look at the set F and at nothing outside of F . Since F has m elements, the denominator in the calculation of $P(E | F)$ is m . We may think that the numerator for our conditional probability is the number of elements in E . But clearly we cannot consider the elements of E that are not in F . We can only count the elements of E that are in F , that is, the elements in $E \cap F$.

Therefore,

$$P(E | F) = \frac{c}{m}$$

Dividing both the numerator and the denominator by n , we get

$$P(E | F) = \frac{c/n}{m/n} \quad (13.40)$$

But $c/n = P(E \cap F)$, and $m/n = P(F)$.

Substituting, we derive the following formula for $P(E | F)$.

13.25

For Two Events E and F , the Probability of E Given F is

$$P(E | F) = \frac{P(E \cap F)}{P(F)} \quad (13.41)$$

Example 13.26

A single die is rolled. Use the above formula to find the conditional probability of obtaining an even number given that a number greater than three has shown.

Solution

Let E be the event that an even number shows, and F be the event that a number greater than three shows. We want $P(E | F)$.

$E = \{2, 4, 6\}$ and $F = \{4, 5, 6\}$. Which implies, $E \cap F = \{4, 6\}$

Therefore, $P(F) = 3/6$, and $P(E \cap F) = 2/6$

$$P(E | F) = \frac{P(E \cap F)}{P(F)} = \frac{2/6}{3/6} = \frac{2}{3}.$$

Example 13.27

The following table shows the distribution by gender of students at a community college who take public transportation and the ones who drive to school.

	Male(M)	Female(F)	Total
Public Transportation(P)	8	13	21
Drive(D)	39	40	79
Total	47	53	100

Table 13.2

The events M , F , P , and D are self explanatory. Find the following probabilities.

- $P(D | M)$
- $P(F | D)$
- $P(M | P)$

Solution

We use the conditional probability formula $P(E | F) = \frac{P(E \cap F)}{P(F)}$.

- $P(D | M) = \frac{P(D \cap M)}{P(M)} = \frac{39/100}{47/100} = \frac{39}{47}$.
- $P(F | D) = \frac{P(F \cap D)}{P(D)} = \frac{40/100}{79/100} = \frac{40}{79}$.
- $P(M | P) = \frac{P(M \cap P)}{P(P)} = \frac{8/100}{21/100} = \frac{8}{21}$.

Example 13.28

Given $P(E) = .5$, $P(F) = .7$, and $P(E \cap F) = .3$. Find the following.

- $P(E | F)$
- $P(F | E)$.

Solution

We use the conditional probability formula $P(E | F) = \frac{P(E \cap F)}{P(F)}$.

- $P(E | F) = \frac{.3}{.7} = \frac{3}{7}$.
- $P(F | E) = .3/.5 = 3/5$.

Example 13.29

Given two mutually exclusive events E and F such that $P(E) = .4$, $P(F) = .9$. Find $P(E | F)$.

Solution

Since E and F are mutually exclusive, $P(E \cap F) = 0$. Therefore,

$$P(E|F) = \frac{0}{.9} = 0.$$

Example 13.30

Given $P(F | E) = .5$, and $P(E \cap F) = .3$. Find $P(E)$.

Solution

Using the conditional probability formula $P(E | F) = \frac{P(E \cap F)}{P(F)}$, we get

$$P(F | E) = \frac{P(E \cap F)}{P(E)} \tag{13.42}$$

Substituting,

$$.5 = \frac{.3}{P(E)} \text{ or } P(E) = 3/5$$

Example 13.31

In a family of three children, find the conditional probability of having two boys and a girl, given that the family has at least two boys.

Solution

Let event E be that the family has two boys and a girl, and let F be the probability that the family has at least two boys. We want $P(E | F)$.

We list the sample space along with the events E and F .

$$S = \{\text{BBB, BBG, BGB, BGG, GBB, GGB, GGG}\} \quad (13.43)$$

$$E = \{\text{BBG, BGB, GBB}\} \text{ and } F = \{\text{BBB, BBG, BGB, GBB}\}$$

$$E \cap F = \{\text{BBG, BGB, GBB}\} \quad (13.44)$$

Therefore, $P(F) = 4/8$, and $P(E \cap F) = 3/8$.

And

$$P(E | F) = \frac{3/8}{4/8} = \frac{3}{4}.$$

Example 13.32

At a community college 65% of the students use IBM computers, 50% use Macintosh computers, and 20% use both. If a student is chosen at random, find the following probabilities.

- The student uses an IBM given that he uses a Macintosh.
- The student uses a Macintosh knowing that he uses an IBM.

Solution

Let event I be that the student uses an IBM computer, and M the probability that he uses a Macintosh.

- $P(I | M) = \frac{.20}{.50} = \frac{2}{5}$
- $P(M | I) = \frac{.20}{.65} = \frac{4}{13}$.

13.6 Independent Events

In Section 13.5 (Conditional Probability), we considered conditional probabilities. In some examples, the probability of an event changed when additional information was provided. For instance, the probability of obtaining a king from a deck of cards, changed from $4/52$ to $4/12$, when we were given the condition that a face card had already shown. This is not always the case. The additional information may or may not alter the probability of the event. For example consider the following example.

Example 13.33

A card is drawn from a deck. Find the following probabilities.

- The card is a king.
- The card is a king given that a red card has shown.

Solution

- Clearly, $P(\text{The card is a king}) = 4/52 = 1/13$.
- To find $P(\text{The card is a king} | \text{A red card has shown})$, we reason as follows:
Since a red card has shown, there are only twenty six possibilities. Of the 26 red cards, there are two kings. Therefore,
 $P(\text{The card is a king} | \text{A red card has shown}) = 2/26 = 1/13$.

The reader should observe that in the above example,

$$P(\text{The card is a king} \mid \text{A red card has shown}) = P(\text{The card is a king})$$

In other words, the additional information, a red card has shown, did not affect the probability of obtaining a king. Whenever the probability of an event E is not affected by the occurrence of another event F , and vice versa, we say that the two events E and F are **independent**. This leads to the following definition.

Two Events E and F are **independent** if and only if at least one of the following two conditions is true.

1. $P(E \mid F) = P(E)$ or
- 2.

$$P(F \mid E) = P(F) \quad (13.45)$$

If the events are not independent, then they are dependent.

Next, we need to develop a test to determine whether two events are independent.

We recall the conditional probability formula.

$$P(E \mid F) = \frac{P(E \cap F)}{P(F)} \quad (13.46)$$

Multiplying both sides by $P(F)$, we get

$$P(E \cap F) = P(E \mid F) P(F) \quad (13.47)$$

Now if the two events are independent, then by definition

$$P(E \mid F) = P(E) \quad (13.48)$$

Substituting, $P(E \cap F) = P(E) P(F)$

We state it formally as follows.

Test for Independence

Two Events E and F are independent if and only if

$$P(E \cap F) = P(E) P(F) \quad (13.49)$$

Example 13.34

The table below shows the distribution of color-blind people by gender.

	Male(M)	Female(F)	Total
Color-Blind(C)	6	1	7
Not Color-Blind (N)	46	47	93
Total	52	48	100

Table 13.3

Where M represents male, F represents female, C represents color-blind, and N not color-blind. Use the independence test to determine whether the events color-blind and male are independent.

Solution

According to the test, C and M are independent if and only if $P(C \cap M) = P(C)P(M)$.

$$P(C) = 7/100, \quad P(M) = 52/100 \quad \text{and} \quad P(C \cap M) = 6/100 \quad (13.50)$$

$$P(C)P(M) = (7/100)(52/100) = .0364 \quad (13.51)$$

and $P(C \cap M) = .06$

Clearly $.0364 \neq .06$

Therefore, the two events are not independent. We may say they are dependent.

Example 13.35

In a survey of 100 women, 45 wore makeup, and 55 did not. Of the 45 who wore makeup, 9 had a low self-image, and of the 55 who did not, 11 had a low self-image. Are the events "wearing makeup" and "having a low self-image" independent?

Solution

Let M be the event that a woman wears makeup, and L the event that a woman has a low self-image. We have

$$P(M \cap L) = 9/100, \quad P(M) = 45/100 \quad \text{and} \quad P(L) = 20/100$$

In order for two events to be independent, we must have

$$P(M \cap L) = P(M)P(L) \quad (13.52)$$

Since $9/100 = (45/100)(20/100)$

The two events "wearing makeup" and "having a low self-image" are independent.

Example 13.36

A coin is tossed three times, and the events E , F and G are defined as follows:

E : The coin shows a head on the first toss.

F : At least two heads appear.

G : Heads appear in two successive tosses.

Determine whether the following events are independent.

- E and F
- F and G
- E and G

Solution

To make things easier, we list the sample space, the events, their intersections and the corresponding probabilities.

$$S = \{HHH, HHT, HTH, HTT, THH, THT, TTH, TTT\} \quad (13.53)$$

$$E = \{HHH, HHT, HTH, HTT\}, \quad P(E) = 4/8 \text{ or } 1/2$$

$$F = \{HHH, HHT, HTH, THH\}, \quad P(F) = 4/8 \text{ or } 1/2$$

$$G = \{HHT, THH\}, \quad P(G) = 2/8 \text{ or } 1/4$$

$$E \cap F = \{HHH, HHT, HTH\}, \quad P(E \cap F) = 3/8$$

$$E \cap G = \{HHT, THH\}, \quad P(E \cap G) = 2/8 \text{ or } 1/4$$

$$E \cap G = \{HHT\} \quad P(E \cap G) = 1/8$$

- a. In order for E and F to be independent, we must have

$$P(E \cap F) = P(E)P(F).$$

$$\text{But } 3/8 \neq 1/2 \cdot 1/2$$

Therefore, E and F are not independent.

- b. F and G will be independent if

$$P(F \cap G) = P(F)P(G).$$

$$\text{Since } 1/4 \neq 1/2 \cdot 1/4$$

F and G are not independent.

- c. We look at

$$P(E \cap G) = P(E)P(G) \tag{13.54}$$

$$1/8 = 1/2 \cdot 1/4 \tag{13.55}$$

Therefore, E and G are independent events.

Example 13.37

The probability that Jaime will visit his aunt in Baltimore this year is .30, and the probability that he will go river rafting on the Colorado river is .50. If the two events are independent, what is the probability that Jaime will do both?

Solution

Let A be the event that Jaime will visit his aunt this year, and R be the event that he will go river rafting.

We are given $P(A) = .30$ and $P(R) = .50$, and we want to find $P(A \cap R)$.

Since we are told that the events A and R are independent,

$$P(A \cap R) = P(A)P(R) = (.30)(.50) = .15. \tag{13.56}$$

Example 13.38

Given $P(B | A) = .4$. If A and B are independent, find $P(B)$.

Solution

If A and B are independent, then by definition $P(B | A) = P(B)$

Therefore, $P(B) = .4$

Example 13.39

Given $P(A) = .7$, $P(B | A) = .5$. Find $P(A \cap B)$.

Solution

By definition $P(B | A) = \frac{P(A \cap B)}{P(A)}$

Substituting, we have

$$.5 = \frac{P(A \cap B)}{.7} \tag{13.57}$$

Therefore, $P(A \cap B) = .35$

Example 13.40

Given $P(A) = .5$, $P(A \cup B) = .7$, if A and B are independent, find $P(B)$.

Solution

The addition rule states that

$$P(A \cup B) = P(A) + P(B) - P(A \cap B) \quad (13.58)$$

Since A and B are independent, $P(A \cap B) = P(A)P(B)$

We substitute for $P(A \cap B)$ in the addition formula and get

$$P(A \cup B) = P(A) + P(B) - P(A)P(B) \quad (13.59)$$

By letting $P(B) = x$, and substituting values, we get

$$.7 = .5 + x - .5x \quad (13.60)$$

$$.7 = .5 + .5x \quad (13.61)$$

$$.2 = .5x \quad (13.62)$$

$$.4 = x \quad (13.63)$$

Therefore, $P(B) = .4$.

Chapter 14

Probability: Homework¹

14.1 SAMPLE SPACES AND PROBABILITY

In problems 1 - 6, write a sample space for the given experiment.

Exercise 14.1

A die is rolled.

(Solution on p. 244.)

Exercise 14.2

A penny and a nickel are tossed.

Exercise 14.3

A die is rolled, and a coin is tossed.

(Solution on p. 244.)

Exercise 14.4

Three coins are tossed.

Exercise 14.5

Two dice are rolled.

(Solution on p. 244.)

Exercise 14.6

A jar contains four marbles numbered 1, 2, 3, and 4. Two marbles are drawn.

In problems 7 - 12, a card is selected from a deck. Find the following probabilities.

Exercise 14.7

(Solution on p. 244.)

$$P(\text{an ace}) \tag{14.1}$$

Exercise 14.8

$$P(\text{a red card}) \tag{14.2}$$

Exercise 14.9

(Solution on p. 244.)

$$P(\text{a club}) \tag{14.3}$$

Exercise 14.10

$$P(\text{a face card}) \tag{14.4}$$

¹This content is available online at <<http://cnx.org/content/m38666/1.1/>>.

Exercise 14.11*(Solution on p. 244.)*

$$P(\text{a jack or spade}) \quad (14.5)$$

Exercise 14.12

$$P(\text{a jack and a spade}) \quad (14.6)$$

A jar contains 6 red, 7 white, and 7 blue marbles. If a marble is chosen at random, find the following probabilities.

Exercise 14.13*(Solution on p. 244.)*

$$P(\text{red}) \quad (14.7)$$

Exercise 14.14

$$P(\text{white}) \quad (14.8)$$

Exercise 14.15*(Solution on p. 244.)*

$$P(\text{red or blue}) \quad (14.9)$$

Exercise 14.16

$$P(\text{red and blue}) \quad (14.10)$$

Consider a family of three children. Find the following probabilities.

Exercise 14.17*(Solution on p. 244.)*

$$P(\text{two boys and a girl}) \quad (14.11)$$

Exercise 14.18

$$P(\text{at least one boy}) \quad (14.12)$$

Exercise 14.19*(Solution on p. 244.)*

$$P(\text{children of both sexes}) \quad (14.13)$$

Exercise 14.20

$$P(\text{at most one girl}) \quad (14.14)$$

Two dice are rolled. Find the following probabilities.

Exercise 14.21

(Solution on p. 245.)

$$P(\text{the sum of the dice is } 5) \quad (14.15)$$

Exercise 14.22

$$P(\text{the sum of the dice is } 8) \quad (14.16)$$

Exercise 14.23

(Solution on p. 245.)

$$P(\text{the sum is } 3 \text{ or } 6) \quad (14.17)$$

Exercise 14.24

$$P(\text{the sum is more than } 10) \quad (14.18)$$

A jar contains four marbles numbered 1, 2, 3, and 4. If two marbles are drawn, find the following probabilities.

Exercise 14.25

(Solution on p. 245.)

$$P(\text{the sum of the number is } 5) \quad (14.19)$$

Exercise 14.26

$$P(\text{the sum of the numbers is odd}) \quad (14.20)$$

Exercise 14.27

(Solution on p. 245.)

$$P(\text{the sum of the numbers is } 9) \quad (14.21)$$

Exercise 14.28

$$P(\text{one of the numbers is } 3) \quad (14.22)$$

14.2 MUTUALLY EXCLUSIVE EVENTS AND THE ADDITION RULE

Determine whether the following pair of events are mutually exclusive.

Exercise 14.29

(Solution on p. 245.)

$$A = \{\text{A person earns more than \$25,000}\} \quad (14.23)$$

$$B = \{\text{A person earns less than \$20,000}\} \quad (14.24)$$

Exercise 14.30

A card is drawn from a deck.

$$C = \{\text{It is a King}\} D = \{\text{It is a heart}\}. \quad (14.25)$$

Exercise 14.31

(Solution on p. 245.)

A die is rolled.

$$E = \{\text{An even number shows}\} \quad (14.26)$$

$$F = \{\text{A number greater than 3 shows}\} \quad (14.27)$$

Exercise 14.32

Two dice are rolled.

$$G = \{\text{The sum of dice is 8}\} \quad (14.28)$$

$$H = \{\text{One die shows a 6}\} \quad (14.29)$$

Exercise 14.33

(Solution on p. 245.)

Three coins are tossed.

$$I = \{\text{Two heads come up}\} \quad (14.30)$$

$$J = \{\text{At least one tail comes up}\} \quad (14.31)$$

Exercise 14.34

A family has three children.

$$K = \{\text{First born is a boy}\} \quad (14.32)$$

$$L = \{\text{The family has children of both sexes}\} \quad (14.33)$$

Use the addition rule to find the following probabilities.

Exercise 14.35*(Solution on p. 245.)*

A card is drawn from a deck, and the events C and D are as follows:

$$C = \{\text{It is a king}\} \quad (14.34)$$

$$D = \{\text{It is a heart}\} \quad (14.35)$$

Find $P(C \text{ or } D)$.

Exercise 14.36

A die is rolled, and the events E and F are as follows:

$$E = \{\text{An even number shows}\} \quad (14.36)$$

$$F = \{\text{A number greater than 3 shows}\} \quad (14.37)$$

Find $P(E \text{ or } F)$.

Exercise 14.37*(Solution on p. 245.)*

Two dice are rolled, and the events G and H are as follows:

$$G = \{\text{The sum of dice is 8}\} \quad (14.38)$$

$$H = \{\text{Exactly one die shows a 6}\} \quad (14.39)$$

Find $P(G \text{ or } H)$.

Exercise 14.38

Three coins are tossed, and the events I and J are as follows:

$$I = \{\text{Two heads come up}\} \quad (14.40)$$

$$J = \{\text{At least one tail comes up}\} \quad (14.41)$$

Find $P(I \text{ or } J)$.

Exercise 14.39*(Solution on p. 245.)*

At De Anza college, 20% of the students take Finite Mathematics, 30% take Statistics and 10% take both. What percentage of the students take Finite Mathematics or Statistics?

Exercise 14.40

This quarter, there is a 50% chance that Jason will pass Accounting, a 60% chance that he will pass English, and 80% chance that he will pass at least one of these two courses. What is the probability that he will pass both Accounting and English?

The following table shows the distribution of Democratic and Republican U.S. Senators by gender.

	MALES(M)	FEMALES(F)	TOTAL
DEMOCRATS(D)	39	4	43
REPUBLICANS(R)	52	5	57
TOTALS	91	9	100

Table 14.1

Use this table to determine the following probabilities.

Exercise 14.41

(Solution on p. 245.)

$$P(M \text{ and } D) \quad (14.42)$$

Exercise 14.42

$$P(F \text{ and } R) \quad (14.43)$$

Exercise 14.43

(Solution on p. 245.)

$$P(M \text{ or } D) \quad (14.44)$$

Exercise 14.44

$$P(F \text{ or } R^C) \quad (14.45)$$

Exercise 14.45

(Solution on p. 245.)

$$P(M^C \text{ or } R) \quad (14.46)$$

Exercise 14.46

$$P(M \text{ or } F) \quad (14.47)$$

Again, use the addition rule to determine the following probabilities.

Exercise 14.47

(Solution on p. 245.)

If $P(E) = .5$ and $P(F) = .4$ and E and F are mutually exclusive, find $P(E \text{ and } F)$.

Exercise 14.48

If $P(E) = .4$ and $P(F) = .2$ and E and F are mutually exclusive, find $P(E \text{ or } F)$.

Exercise 14.49

(Solution on p. 245.)

If $P(E) = .3$ and $P(E \text{ or } F) = .6$ and $P(E \text{ and } F) = .2$, find $P(F)$.

Exercise 14.50

If $P(E) = .4$, $P(F) = .5$ and $P(E \text{ or } F) = .7$, find $P(E \text{ and } F)$.

14.3 CALCULATING PROBABILITIES USING TREE DIAGRAMS AND COMBINATIONS

Two apples are chosen from a basket containing five red and three yellow apples. Draw a tree diagram below, and find the following probabilities.

Exercise 14.51

(Solution on p. 245.)

$$P(\text{both red}) \quad (14.48)$$

Exercise 14.52

$$P(\text{one red, one yellow}) \quad (14.49)$$

Exercise 14.53*(Solution on p. 245.)*

$$P(\text{both yellow}) \quad (14.50)$$

Exercise 14.54

$$P(\text{First red and second yellow}) \quad (14.51)$$

A basket contains six red and four blue marbles. Three marbles are drawn at random. Find the following probabilities using the method shown in Example 13.2. Do not use combinations.

Exercise 14.55*(Solution on p. 245.)*

$$P(\text{All three red}) \quad (14.52)$$

Exercise 14.56

$$P(\text{two red, one blue}) \quad (14.53)$$

Exercise 14.57*(Solution on p. 246.)*

$$P(\text{one red, two blue}) \quad (14.54)$$

Exercise 14.58

$$P(\text{first red, second blue, third red}) \quad (14.55)$$

Three marbles are drawn from a jar containing five red, four white, and three blue marbles. Find the following probabilities using combinations.

Exercise 14.59*(Solution on p. 246.)*

$$P(\text{all three red}) \quad (14.56)$$

Exercise 14.60

$$P(\text{two white and 1 blue}) \quad (14.57)$$

Exercise 14.61*(Solution on p. 246.)*

$$P(\text{none white}) \quad (14.58)$$

Exercise 14.62

$$P(\text{at least one red}) \qquad (14.59)$$

A committee of four is selected from a total of 4 freshmen, 5 sophomores, and 6 juniors. Find the probabilities for the following events.

Exercise 14.63 *(Solution on p. 246.)*

At least three freshmen.

Exercise 14.64

No sophomores.

Exercise 14.65 *(Solution on p. 246.)*

All four of the same class.

Exercise 14.66

Not all four from the same class.

Exercise 14.67 *(Solution on p. 246.)*

Exactly three of the same class.

Exercise 14.68

More juniors than freshmen and sophomores combined.

Five cards are drawn from a deck. Find the probabilities for the following events.

Exercise 14.69 *(Solution on p. 246.)*

Two hearts, two spades, and one club.

Exercise 14.70

A flush of any suit (all cards of a single suit).

Exercise 14.71 *(Solution on p. 246.)*

A full house of nines and tens (3 nines and 2 tens).

Exercise 14.72

Any full house.

Exercise 14.73 *(Solution on p. 246.)*

A pair of nines and tens.

Exercise 14.74

Two pairs

Do the following birthday problems.

Exercise 14.75 *(Solution on p. 246.)*

If there are five people in a room, what is the probability that no two have the same birthday?

Exercise 14.76

If there are five people in a room, what is the probability that at least two people have the same birthday?

14.4 CONDITIONAL PROBABILITY

Do the following problems using the conditional probability formula: $P(A | B) = \frac{P(A \cap B)}{P(B)}$.

Exercise 14.77 *(Solution on p. 246.)*

A card is drawn from a deck. Find the conditional probability of $P(\text{a queen} | \text{a face card})$.

Exercise 14.78

A card is drawn from a deck. Find the conditional probability of $P(\text{a queen} | \text{a club})$.

Exercise 14.79 *(Solution on p. 246.)*

A die is rolled. Find the conditional probability that it shows a three if it is known that an odd number has shown.

Exercise 14.80

If $P(A) = .3$ and $P(B) = .4$, and $P(A \text{ and } B) = .12$, find the following.

- a. $P(A | B)$
- b. $P(B | A)$

The following table shows the distribution of Democratic and Republican U.S. Senators by gender.

	MALE(M)	FEMALE(F)	TOTAL
DEMOCRATS(D)	39	4	43
REPUBLICANS(R)	52	5	57
TOTALS	91	9	100

Table 14.2

Use this table to determine the following probabilities:

Exercise 14.81 *(Solution on p. 246.)*

$$P(M | D) \quad (14.60)$$

Exercise 14.82

$$P(D | M) \quad (14.61)$$

Exercise 14.83 *(Solution on p. 246.)*

$$P(F | R) \quad (14.62)$$

Exercise 14.84

$$P(R | F) \quad (14.63)$$

Do the following conditional probability problems.

Exercise 14.85 *(Solution on p. 246.)*

At De Anza College, 20% of the students take Finite Math, 30% take History, and 5% take both Finite Math and History. If a student is chosen at random, find the following conditional probabilities.

- He is taking Finite Math given that he is taking History.
- He is taking History assuming that he is taking Finite Math.

Exercise 14.86

At a college, 60% of the students pass Accounting, 70% pass English, and 30% pass both of these courses. If a student is selected at random, find the following conditional probabilities.

- He passes Accounting given that he passed English.
- He passes English assuming that he passed Accounting.

Exercise 14.87*(Solution on p. 247.)*

If $P(F) = .4$ and $P(E | F) = .3$, find $P(E \text{ and } F)$.

Exercise 14.88

If $P(E) = .3$, and $P(F) = .3$, and E and F are mutually exclusive, find $P(E | F)$.

Exercise 14.89*(Solution on p. 247.)*

If $P(E) = .6$ and $P(E \text{ and } F) = .24$, find $P(F | E)$.

Exercise 14.90

If $P(E \text{ and } F) = .04$ and $P(E | F) = .1$, find $P(F)$.

Consider a family of three children. Find the following probabilities.

Exercise 14.91*(Solution on p. 247.)*

$$P(\text{two boys} \mid \text{first born is a boy}) \quad (14.64)$$

Exercise 14.92

$$P(\text{all girls} \mid \text{at least one girl is born}) \quad (14.65)$$

Exercise 14.93*(Solution on p. 247.)*

$$P(\text{children of both sexes} \mid \text{first born is a boy}) \quad (14.66)$$

Exercise 14.94

$$P(\text{all boys} \mid \text{there are children of both sexes}) \quad (14.67)$$

14.5 INDEPENDENT EVENTS

The distribution of the number of fiction and non-fiction books checked out at a city's main library and at a smaller branch on a given day is as follows.

	MAIN(M)	BRANCH(B)	TOTAL
FICTION(F)	300	100	400
NON-FICTION(N)	150	50	200
TOTALS	450	150	600

Table 14.3

Use this table to determine the following probabilities:

Exercise 14.95*(Solution on p. 247.)*

$$P(F) \quad (14.68)$$

Exercise 14.96

$$P(M | F) \quad (14.69)$$

Exercise 14.97*(Solution on p. 247.)*

$$P(N | B) \quad (14.70)$$

Exercise 14.98

Is the fact that a person checks out a fiction book independent of the main library?

For a two-child family, let the events E , F , and G be as follows.

E : The family has at least one boy F : The family has children of both sexes G : The family's first born is a boy

Exercise 14.99*(Solution on p. 247.)*

Find the following.

- $P(E)$
- $P(F)$
- $P(E \cap F)$
- Are E and F independent?

Exercise 14.100

Find the following.

- $P(F)$
- $P(G)$
- $P(F \cap G)$
- Are F and G independent?

Do the following problems involving independence.

Exercise 14.101*(Solution on p. 247.)*

If $P(E) = .6$, $P(F) = .2$, and E and F are independent, find $P(E \text{ and } F)$.

Exercise 14.102

If $P(E) = .6$, $P(F) = .2$, and E and F are independent, find $P(E \text{ or } F)$.

Exercise 14.103*(Solution on p. 247.)*

If $P(E) = .9$, $P(F | E) = .36$, and E and F are independent, find $P(F)$.

Exercise 14.104

If $P(E) = .6$, $P(E \text{ or } F) = .08$, and E and F are independent, find $P(F)$.

Exercise 14.105*(Solution on p. 247.)*

In a survey of 100 people, 40 were casual drinkers, and 60 did not drink. Of the ones who drank, 6 had minor headaches. Of the non-drinkers, 9 had minor headaches. Are the events "drinkers" and "had headaches" independent?

Exercise 14.106

It is known that 80% of the people wear seat belts, and 5% of the people quit smoking last year. If 4% of the people who wear seat belts quit smoking, are the events, wearing a seat belt and quitting smoking, independent?

Exercise 14.107

(Solution on p. 247.)

John's probability of passing statistics is 40%, and Linda's probability of passing the same course is 70%. If the two events are independent, find the following probabilities.

- P (both of them will pass statistics)
- P (at least one of them will pass statistics)

Exercise 14.108

Jane is flying home for the Christmas holidays. She has to change planes twice on the way home. There is an 80% chance that she will make the first connection, and a 90% chance that she will make the second connection. If the two events are independent, find the following probabilities.

- P (Jane will make both connections)
- P (Jane will make at least one connection)

For a three-child family, let the events E , F , and G be as follows.

E : The family has at least one boy F : The family has children of both sexes G : The family's first born is a boy

Exercise 14.109

(Solution on p. 247.)

Find the following.

- $P(E)$
- $P(F)$
- $P(E \cap F)$
- Are E and F independent?

Exercise 14.110

Find the following.

- $P(F)$
- $P(G)$
- $P(F \cap G)$
- Are F and G independent?

14.6 CHAPTER REVIEW

Exercise 14.111

(Solution on p. 247.)

Two dice are rolled. Find the probability that the sum of the dice is

- four
- five

Exercise 14.112

(Solution on p. 247.)

A jar contains 3 red, 4 white, and 5 blue marbles. If a marble is chosen at random, find the following probabilities:

- P (red or blue)

- b. $P(\text{not blue})$

Exercise 14.113*(Solution on p. 247.)*

A card is drawn from a standard deck. Find the following probabilities:

- a. $P(\text{a jack or a king})$
 b. $P(\text{a jack or a spade})$

Exercise 14.114*(Solution on p. 248.)*

A basket contains 3 red and 2 yellow apples. Two apples are chosen at random. Find the following probabilities:

- a. $P(\text{one red, one yellow})$
 b. $P(\text{at least one red})$

Exercise 14.115*(Solution on p. 248.)*

A basket contains 4 red, 3 white, and 3 blue marbles. Three marbles are chosen at random. Find the following probabilities:

- a. $P(\text{two red, one white})$
 b. $P(\text{first red, second white, third blue})$
 c. $P(\text{at least one red})$
 d. $P(\text{none red})$

Exercise 14.116*(Solution on p. 248.)*

Given a family of four children. Find the following probabilities:

- a. $P(\text{All boys})$
 b. $P(\text{1 boy and 3 girls})$

Exercise 14.117*(Solution on p. 248.)*

Consider a family of three children. Find the following:

- a. $P(\text{children of both sexes} \mid \text{first born is a boy})$
 b. $P(\text{all girls} \mid \text{children of both sexes})$

Exercise 14.118*(Solution on p. 248.)*

Mrs. Rossetti is flying from San Francisco to New York. On her way to the San Francisco Airport she encounters heavy traffic and determines that there is a 20% chance that she will be late to the airport and will miss her flight. Even if she makes her flight, there is a 10% chance that she will miss her connecting flight at Chicago. What is the probability that she will make it to New York as scheduled?

Exercise 14.119*(Solution on p. 248.)*

At a college, twenty percent of the students take history, thirty percent take math, and ten percent take both. What percent of the students take at least one of these two courses?

Exercise 14.120*(Solution on p. 248.)*

In a T-maze, a mouse may run to the right (R) or may run to the left (L). A mouse goes up the maze three times, and events E and F are described as follows:

- E : Runs to the right on the first trial
 F : Runs to the left two consecutive times

Determine whether the events E and F are independent.

Exercise 14.121*(Solution on p. 248.)*

A college has found that 20% of its students take advanced math courses, 40% take advanced English courses and 15% take both advanced math and advanced English courses. If a student is selected at random, what is the probability that

- he is taking English given that he is taking math?
- he is taking math or English?

Exercise 14.122*(Solution on p. 248.)*

If there are 35 students in a class, what is the probability that at least two have the same birthday?

Exercise 14.123*(Solution on p. 248.)*

A student feels that her probability of passing accounting is .62, of passing mathematics is .45, and her passing accounting or mathematics is .85. Find the probability that the student passes both accounting and math.

Exercise 14.124*(Solution on p. 248.)*

There are nine judges on the U. S. Supreme Court of which five are conservative and four liberal. This year the court will act on six major cases. What is the probability that out of six cases the court will favor the conservatives in at least four?

Exercise 14.125*(Solution on p. 248.)*

Five cards are drawn from a deck. Find the probability of obtaining

- four cards of a single suit
- two cards of one suit, two of another suit, and one from the remaining
- a pair (e.g. two aces and three other cards)
- a straight flush (five in a row of a single suit but not a royal flush)

Exercise 14.126*(Solution on p. 248.)*

The following table shows a distribution of drink preferences by gender.

	Coke(C)	Pepsi(P)	Seven Up(S)	TOTALS
Males(M)	60	50	22	132
Females(F)	50	40	18	108
TOTALS	110	90	40	240

Table 14.4

The events M , F , C , P and S are defined as Male, Female, Coca Cola, Pepsi, and Seven Up, respectively. Find the following:

- $P(F | S)$
- $P(P | F)$
- $P(C | M)$
- $P(M | P \cup C)$
- Are the events F and S mutually exclusive?
- Are the events F and S independent?

Exercise 14.127*(Solution on p. 249.)*

At a clothing outlet 20% of the clothes are irregular, 10% have at least a button missing and 4% are both irregular and have a button missing. If Martha found a dress that has a button missing, what is the probability that it is irregular?

Exercise 14.128*(Solution on p. 249.)*

A trade delegation consists of four Americans, three Japanese and two Germans. Three people are chosen at random. Find the following probabilities:

- P (two Americans and one Japanese)

- b. P (at least one American)
- c. P (One of each nationality)
- d. P (no German)

Exercise 14.129*(Solution on p. 249.)*

A coin is tossed three times, and the events E and F are as follows.

E : It shows a head on the first toss F : Never turns up a tail

Are the events E and F independent?

Exercise 14.130*(Solution on p. 249.)*

If $P(E) = .6$ and $P(F) = .4$ and E and F are mutually exclusive, find $P(E \text{ and } F)$.

Exercise 14.131*(Solution on p. 249.)*

If $P(E) = .5$ and $P(F) = .3$ and E and F are independent, find $P(E \cup F)$.

Exercise 14.132*(Solution on p. 249.)*

If $P(F) = .9$ and $P(E | F) = .36$ and E and F are independent, find $P(E)$.

Exercise 14.133*(Solution on p. 249.)*

If $P(E) = .4$ and $P(E \text{ or } F) = .9$ and E and F are independent, find $P(F)$.

Exercise 14.134*(Solution on p. 249.)*

If $P(E) = .4$ and $P(F | E) = .5$, find $P(E \text{ and } F)$.

Exercise 14.135*(Solution on p. 249.)*

If $P(E) = .6$ and $P(E \text{ and } F) = .3$, find $P(F | E)$.

Exercise 14.136*(Solution on p. 249.)*

If $P(E) = .3$ and $P(F) = .4$ and E and F are independent, find $P(E | F)$.

Solutions to Exercises in Chapter 14

Solutions to Probability: Homework

Solution to Exercise 14.1 (p. 229)

$$\{1, 2, 3, 4, 5, 6\} \quad (14.71)$$

Solution to Exercise 14.3 (p. 229)

$$\{1H, 2H, 3H, 4H, 5H, 6H, 1T, 2T, 3T, 4T, 5T, 6T\} \quad (14.72)$$

Solution to Exercise 14.5 (p. 229)

	1	2	3	4	5	6
1	(1, 1)	(1, 2)	(1, 3)	(1, 4)	(1, 5)	(1, 6)
2	(2, 1)	(2, 2)	(2, 3)	(2, 4)	(2, 5)	(2, 6)
3	(3, 1)	(3, 2)	(3, 3)	(3, 4)	(3, 5)	(3, 6)
4	(4, 1)	(4, 2)	(4, 3)	(4, 4)	(4, 5)	(4, 6)
5	(5, 1)	(5, 2)	(5, 3)	(5, 4)	(5, 5)	(5, 6)
6	(6, 1)	(6, 2)	(6, 3)	(6, 4)	(6, 5)	(6, 6)

Table 14.5

Solution to Exercise 14.7 (p. 229)

$$4/52 \quad (14.73)$$

Solution to Exercise 14.9 (p. 229)

$$13/52 \quad (14.74)$$

Solution to Exercise 14.11 (p. 230)

$$16/52 \quad (14.75)$$

Solution to Exercise 14.13 (p. 230)

$$6/20 \quad (14.76)$$

Solution to Exercise 14.15 (p. 230)

$$13/20 \quad (14.77)$$

Solution to Exercise 14.17 (p. 230)

$$3/8 \quad (14.78)$$

Solution to Exercise 14.19 (p. 230)

$$6/8 \quad (14.79)$$

Solution to Exercise 14.21 (p. 231)		
	4/36	(14.80)
Solution to Exercise 14.23 (p. 231)		
	7/36	(14.81)
Solution to Exercise 14.25 (p. 231)		
	4/12	(14.82)
Solution to Exercise 14.27 (p. 231)		
0		
Solution to Exercise 14.29 (p. 232)		
Yes		
Solution to Exercise 14.31 (p. 232)		
No		
Solution to Exercise 14.33 (p. 232)		
No		
Solution to Exercise 14.35 (p. 232)		
	16/52	(14.83)
Solution to Exercise 14.37 (p. 233)		
	13/36	(14.84)
Solution to Exercise 14.39 (p. 233)		
40%		
Solution to Exercise 14.41 (p. 234)		
	39/100	(14.85)
Solution to Exercise 14.43 (p. 234)		
	95/100	(14.86)
Solution to Exercise 14.45 (p. 234)		
	61/100	(14.87)
Solution to Exercise 14.47 (p. 234)		
0		
Solution to Exercise 14.49 (p. 234)		
0.5		
Solution to Exercise 14.51 (p. 234)		
	20/56	(14.88)
Solution to Exercise 14.53 (p. 235)		
	6/56	(14.89)
Solution to Exercise 14.55 (p. 235)		
	1/6	(14.90)

Solution to Exercise 14.57 (p. 235)		
	$3/10$	(14.91)
Solution to Exercise 14.59 (p. 235)		
	$10/220$	(14.92)
Solution to Exercise 14.61 (p. 235)		
	$56/220$	(14.93)
Solution to Exercise 14.63 (p. 236)		
	$45/1365$	(14.94)
Solution to Exercise 14.65 (p. 236)		
	$21/1365$	(14.95)
Solution to Exercise 14.67 (p. 236)		
	$324/1365$	(14.96)
Solution to Exercise 14.69 (p. 236)		
	$79092/2,598,960$	(14.97)
Solution to Exercise 14.71 (p. 236)		
	$24/2,598,960$	(14.98)
Solution to Exercise 14.73 (p. 236)		
	$1,584/2,598,960$	(14.99)
Solution to Exercise 14.75 (p. 236)		
0.973		
Solution to Exercise 14.77 (p. 237)		
	$4/12$	(14.100)
Solution to Exercise 14.79 (p. 237)		
	$1/3$	(14.101)
Solution to Exercise 14.81 (p. 237)		
	$39/43$	(14.102)
Solution to Exercise 14.83 (p. 237)		
$5/57$		
Solution to Exercise 14.85 (p. 237)		
a. $1/6$		
b. $1/4$		

Solution to Exercise 14.87 (p. 238)

0.12

Solution to Exercise 14.89 (p. 238)

0.4

Solution to Exercise 14.91 (p. 238)

$2/4$

(14.103)

Solution to Exercise 14.93 (p. 238)

$3/4$

(14.104)

Solution to Exercise 14.95 (p. 239)

$2/3$

(14.105)

Solution to Exercise 14.97 (p. 239)

$50/150$

(14.106)

Solution to Exercise 14.99 (p. 239)

- a. $3/4$
- b. $2/4$
- c. $2/4$
- d. no

Solution to Exercise 14.101 (p. 239)

0.12

Solution to Exercise 14.103 (p. 239)

0.36

Solution to Exercise 14.105 (p. 239)

Yes

Solution to Exercise 14.107 (p. 240)

- a. $28/100$
- b. $82/100$

Solution to Exercise 14.109 (p. 240)

- a. $7/8$
- b. $6/8$
- c. $6/8$
- d. no

Solution to Exercise 14.111 (p. 240)

- a. $3/36$
- b. $4/36$

Solution to Exercise 14.112 (p. 240)

- a. $8/12$
- b. $7/12$

Solution to Exercise 14.113 (p. 241)

- a. $8/52$

b. $16/52$

Solution to Exercise 14.114 (p. 241)

- a. $3/5$
- b. $9/10$

Solution to Exercise 14.115 (p. 241)

- a. $3/20$
- b. $1/20$
- c. $5/6$
- d. $1/6$

Solution to Exercise 14.116 (p. 241)

- a. $1/16$
- b. $1/4$

Solution to Exercise 14.117 (p. 241)

- a. $3/4$
- b. 0

Solution to Exercise 14.118 (p. 241)

0.72

Solution to Exercise 14.119 (p. 241)

40%

Solution to Exercise 14.120 (p. 241)

independent

Solution to Exercise 14.121 (p. 241)

- a. $3/4$
- b. 0.45

Solution to Exercise 14.122 (p. 242)

0.8144

Solution to Exercise 14.123 (p. 242)

0.22

Solution to Exercise 14.124 (p. 242)

0.45278

Solution to Exercise 14.125 (p. 242)

- a. $111540/2598960$
- b. $949104/2598960$
- c. $1349088/2598960$
- d. $36/2598960$

Solution to Exercise 14.126 (p. 242)

- a. $9/20$
- b. $10/27$
- c. $15/33$
- d. $11/20$
- e. no
- f. yes

Solution to Exercise 14.127 (p. 242)

0.40

Solution to Exercise 14.128 (p. 242)

- a. $3/14$
- b. $37/42$
- c. $2/7$
- d. $35/84$

Solution to Exercise 14.129 (p. 243)

No

Solution to Exercise 14.130 (p. 243)

0

Solution to Exercise 14.131 (p. 243)

0.65

Solution to Exercise 14.132 (p. 243)

0.36

Solution to Exercise 14.133 (p. 243)

5/6

(14.107)

Solution to Exercise 14.134 (p. 243)

0.2

Solution to Exercise 14.135 (p. 243)

0.5

Solution to Exercise 14.136 (p. 243)

0.3

Chapter 15

More Probability¹

15.1 Chapter Overview

In this chapter, you will learn to:

1. Find the probability of a binomial experiment.
2. Find probabilities using Bayes' Formula.
3. Find the expected value or payoff in a game of chance.
4. Find probabilities using tree diagrams.

15.2 Binomial Probability

In this section, we will consider types of problems that involve a sequence of trials, where each trial has only two outcomes, a success or a failure. These trials are independent, that is, the outcome of one does not affect the outcome of any other trial. Furthermore, the probability of success, p , and the probability of failure, $(1 - p)$, remains the same throughout the experiment. These problems are called **binomial probability** problems. Since these problems were researched by a Swiss mathematician named Jacques Bernoulli around 1700, they are also referred to as **Bernoulli trials**.

We give the following definition:

Binomial Experiment

A binomial experiment satisfies the following four conditions:

1. There are only two outcomes, a success or a failure, for each trial.
2. The same experiment is repeated several times.
3. The trials are independent; that is, the outcome of a particular trial does not affect the outcome of any other trial.
4. The probability of success remains the same for every trial.

The probability model that we are about to investigate will give us the tools to solve many real-life problems like the ones given below.

1. If a coin is flipped 10 times, what is the probability that it will fall heads 3 times?
2. If a basketball player makes 3 out of every 4 free throws, what is the probability that he will make 7 out of 10 free throws in a game?
3. If a medicine cures 80% of the people who take it, what is the probability that among the ten people who take the medicine, 6 will be cured?

¹This content is available online at <http://cnx.org/content/m18908/1.2/>.

4. If a microchip manufacturer claims that only 4% of his chips are defective, what is the probability that among the 60 chips chosen, exactly three are defective?
5. If a telemarketing executive has determined that 15% of the people contacted will purchase the product, what is the probability that among the 12 people who are contacted, 2 will buy the product?

We now consider the following example to develop a formula for finding the probability of k successes in n Bernoulli trials.

Example 15.1

A baseball player has a batting average of .300. If he bats four times in a game, find the probability that he will have

- a. four hits
- b. three hits
- c. two hits
- d. one hit
- e. no hits.

Solution

Let us suppose S denotes that the player gets a hit, and F denotes that he does not get a hit.

This is a binomial experiment because it meets all four conditions. First, there are only two outcomes, S or F . Clearly the experiment is repeated four times. Lastly, if we assume that the player's skillfulness to get a hit does not change each time he comes to bat, the trials are independent with a probability of .3 of getting a hit during each trial.

We draw a tree diagram to show all situations.

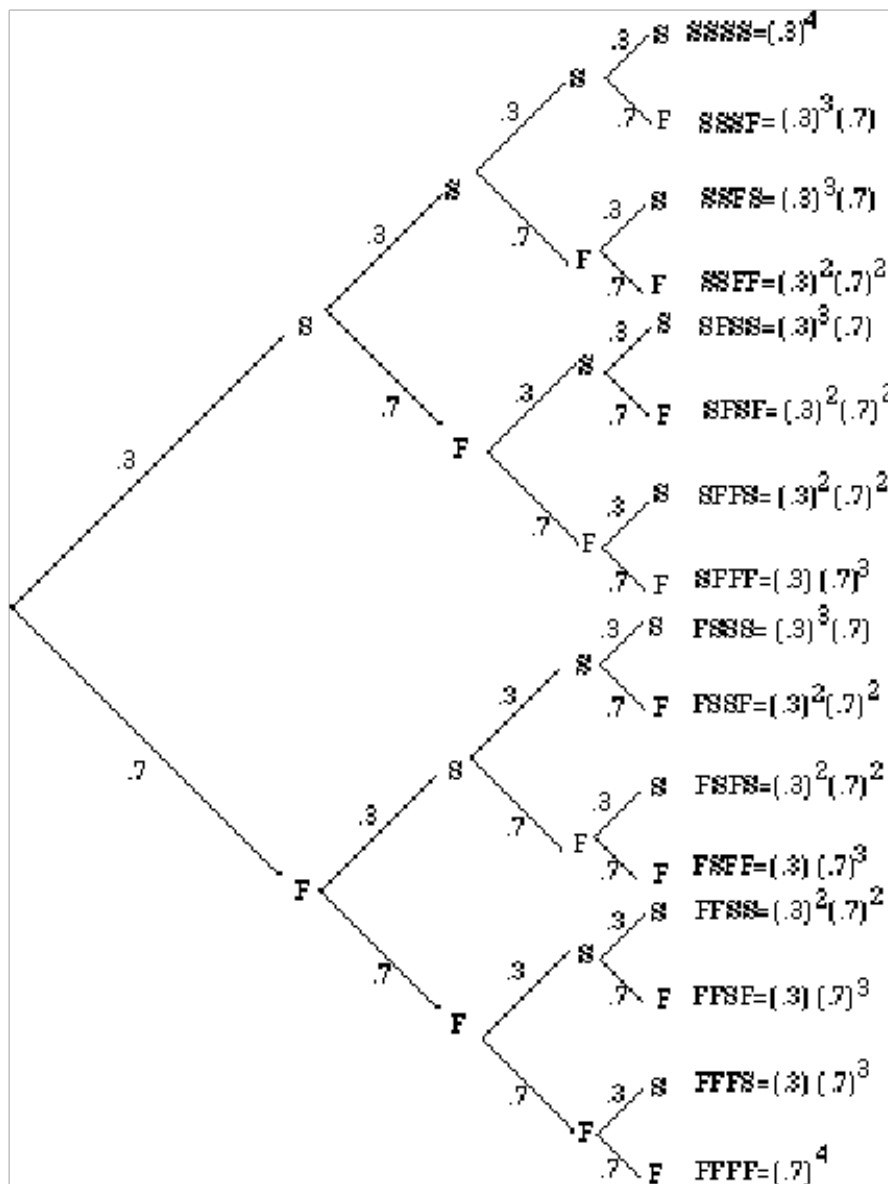

Figure 15.1

Let us first find the probability of getting, for example, two hits. We will have to consider the six possibilities, SSFF, SFSF, SFFS, FSSF, FSFS, FFSS, as shown in the above tree diagram. We list the probabilities of each below.

$$P(SSFF) = (.3)(.3)(.7)(.7) = (.3)^2(.7)^2$$

$$P(SFSF) = (.3)(.7)(.3)(.7) = (.3)^2(.7)^2$$

$$P(SFFS) = (.3)(.7)(.7)(.3) = (.3)^2(.7)^2$$

$$P(FSSF) = (.7)(.3)(.3)(.7) = (.3)^2(.7)^2$$

$$P(FSFS) = (.7)(.3)(.7)(.3) = (.3)^2(.7)^2$$

$$P(\text{FFSS}) = (.7)(.7)(.3)(.3) = (.3)^2(.7)^2$$

Since the probability of each of these six outcomes is $(.3)^2(.7)^2$, the probability of obtaining two successes is $6(.3)^2(.7)^2$.

The probability of getting one hit can be obtained in the same way. Since each permutation has one S and three F 's, there are four such outcomes: SFFF, FSFF, FF SF, and FFFS.

And since the probability of each of the four outcomes is $(.3)(.7)^3$, the probability of getting one hit is $4(.3)(.7)^3$.

The table below lists the probabilities for all cases, and shows a comparison with the binomial expansion of fourth degree. Again, p denotes the probability of success, and $q = (1 - p)$ the probability of failure.

Outcome	Four Hits	Three hits	Two Hits	One hits	No Hits
Probability	$(.3)^4$	$4(.3)^3(.7)$	$6(.3)^2(.7)^2$	$4(.3)(.7)^3$	$(.7)^4$

Table 15.1

This gives us the following theorem:

Theorem 15.1:

Binomial Probability Theorem

The probability of obtaining k successes in n independent Bernoulli trials is given by

$$P(n, k; p) = {}_n C_k p^k q^{n-k} \quad (15.1)$$

where p denotes the probability of success and $q = (1 - p)$ the probability of failure.

We use the above formula to solve the following examples.

Example 15.2

If a coin is flipped 10 times, what is the probability that it will fall heads 3 times?

Solution

Let S denote the probability of obtaining a head, and F the probability of obtaining a tail.

Clearly, $n = 10$, $k = 3$, $p = 1/2$, and $q = 1/2$.

Therefore,

$$b(10, 3; 1/2) = {}_{10} C_3 (1/2)^3 (1/2)^7 = .1172 \quad (15.2)$$

Example 15.3

If a basketball player makes 3 out of every 4 free throws, what is the probability that he will make 6 out of 10 free throws in a game?

Solution

The probability of making a free throw is $3/4$. Therefore, $p = 3/4$, $q = 1/4$, $n = 10$, and $k = 6$.

Therefore,

$$b(10, 6; 3/4) = {}_{10} C_6 (3/4)^6 (1/4)^4 = .1460 \quad (15.3)$$

Example 15.4

If a medicine cures 80% of the people who take it, what is the probability that of the eight people who take the medicine, 5 will be cured?

Solution

Here $p = .80$, $q = .20$, $n = 8$, and $k = 5$.

$$b(8, 5; .80) = {}_8C_5(.80)^5(.20)^3 = .1468 \quad (15.4)$$

Example 15.5

If a microchip manufacturer claims that only 4% of his chips are defective, what is the probability that among the 60 chips chosen, exactly three are defective?

Solution

If S denotes the probability that the chip is defective, and F the probability that the chip is not defective, then $p = .04$, $q = .96$, $n = 60$, and $k = 3$.

$$b(60, 3; .04) = {}_{60}C_3(.04)^3(.96)^{57} = .2138 \quad (15.5)$$

Example 15.6

If a telemarketing executive has determined that 15% of the people contacted will purchase the product, what is the probability that among the 12 people who are contacted, 2 will buy the product?

Solution

If S denoted the probability that a person will buy the product, and F the probability that the person will not buy the product, then $p = .15$, $q = .85$, $n = 12$, and $k = 2$.

$$b(12, 2, .15) = {}_{12}C_2(.15)^2(.85)^{10} = .2924.$$

15.3 Bayes' Formula

In this section, we will develop and use Bayes' Formula to solve an important type of probability problem. Bayes' formula is a method of calculating the conditional probability $P(F | E)$ from $P(E | F)$. The ideas involved here are not new, and most of these problems can be solved using a tree diagram. However, Bayes' formula does provide us with a tool with which we can solve these problems without a tree diagram.

We begin with an example.

Example 15.7

Suppose you are given two jars. Jar I contains one black and 4 white marbles, and Jar II contains 4 black and 6 white marbles. If a jar is selected at random and a marble is chosen,

- What is the probability that the marble chosen is a black marble?
- If the chosen marble is black, what is the probability that it came from Jar I?
- If the chosen marble is black, what is the probability that it came from Jar II?

Solution

Let $J I$ be the event that Jar I is chosen, $J II$ be the event that Jar II is chosen, B be the event that a black marble is chosen and W the event that a white marble is chosen.

We illustrate using a tree diagram.

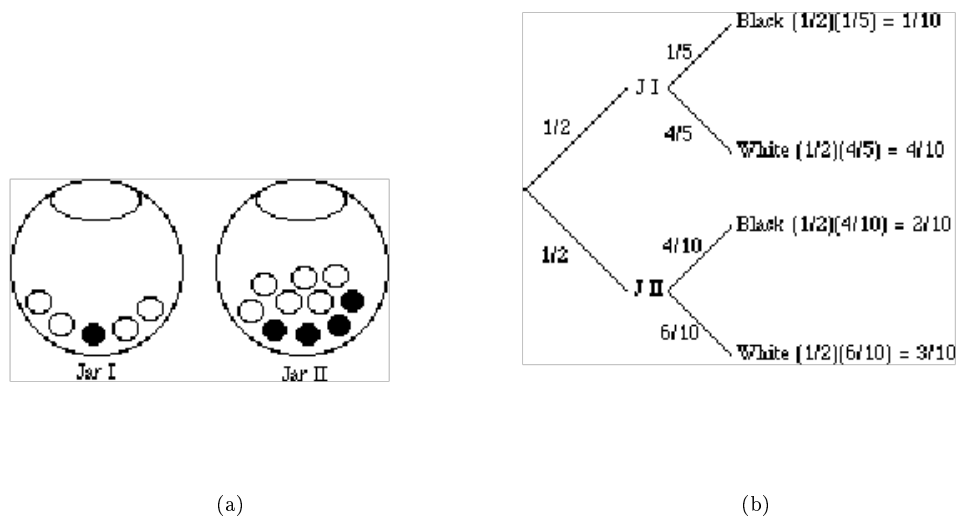

Figure 15.2

- The probability that a black marble is chosen is $P(B) = 1/10 + 2/10 = 3/10$.
- To find $P(J I | B)$, we use the definition of conditional probability, and we get

$$P(J I | B) = \frac{P(J I \cap B)}{P(B)} = \frac{1/10}{3/10} = \frac{1}{3} \quad (15.6)$$

- Similarly, $P(J II | B) = \frac{P(J II \cap B)}{P(B)} = \frac{2/10}{3/10} = \frac{2}{3}$

In parts b and c, the reader should note that the denominator is the sum of all probabilities of all branches of the tree that produce a black marble, while the numerator is the branch that is associated with the particular jar in question.

We will soon discover that this is a statement of Bayes' formula .

Let us first visualize the problem.

We are given a sample space S and two mutually exclusive events $J I$ and $J II$. That is, the two events, $J I$ and $J II$, divide the sample space into two parts such that $J I \cup J II = S$. Furthermore, we are given an event B that has elements in both $J I$ and $J II$, as shown in the Venn diagram below.

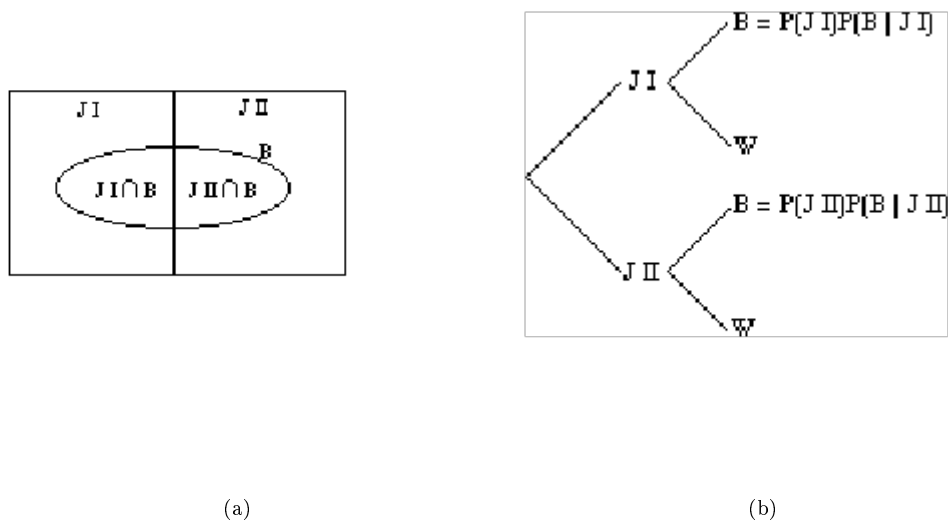

Figure 15.3

From the Venn diagram, we can see that

$$B = (B \cap J I) \cup (B \cap J II)$$

and

$$P(B) = P(B \cap J I) + P(B \cap J II)$$

But the product rule in Chapter 13 gives us

$$P(B \cap J I) = P(J I) \cdot P(B | J I) \quad P(B \cap J II) = P(J II) \cdot P(B | J II)$$

Substituting in p. 257, we get

$$P(B) = P(J I) \cdot P(B | J I) + P(J II) \cdot P(B | J II)$$

The conditional probability formula gives us

$$P(J I | B) = \frac{P(J I \cap B)}{P(B)}$$

Therefore,

$$P(J I | B) = \frac{P(J I \cdot P(B | J I))}{P(B)}$$

or,

$$P(J I | B) = \frac{P(J I) \cdot P(B | J I)}{P(J I) \cdot P(B | J I) + P(J II) \cdot P(B | J II)}$$

The last statement is Bayes' Formula for the case where the sample space is divided into two partitions.

The following is the generalization of this formula for n partitions.

15.8

Let S be a sample space that is divided into n partitions, A_1, A_2, \dots, A_n . If E is any event in S , then

$$P(A_i | E) = \frac{P(A_i) P(E | A_i)}{P(A_1) P(E | A_1) + P(A_2) P(E | A_2) + \dots + P(A_n) P(E | A_n)} \quad (15.7)$$

We begin with the following example.

Example 15.9

A department store buys 50% of its appliances from Manufacturer A, 30% from Manufacturer B, and 20% from Manufacturer C. It is estimated that 6% of Manufacturer A's appliances, 5% of Manufacturer B's appliances, and 4% of Manufacturer C's appliances need repair before the warranty expires. An appliance is chosen at random. If the appliance chosen needed repair before

the warranty expired, what is the probability that the appliance was manufactured by Manufacturer A? Manufacturer B? Manufacturer C?

Solution

Let events A , B and C be the events that the appliance is manufactured by Manufacturer A, Manufacturer B, and Manufacturer C, respectively. Further, suppose that the event R denotes that the appliance needs repair before the warranty expires.

We need to find $P(A | R)$, $P(B | R)$ and $P(C | R)$.

We will do this problem both by using a tree diagram and by using Bayes' formula.

We draw a tree diagram.

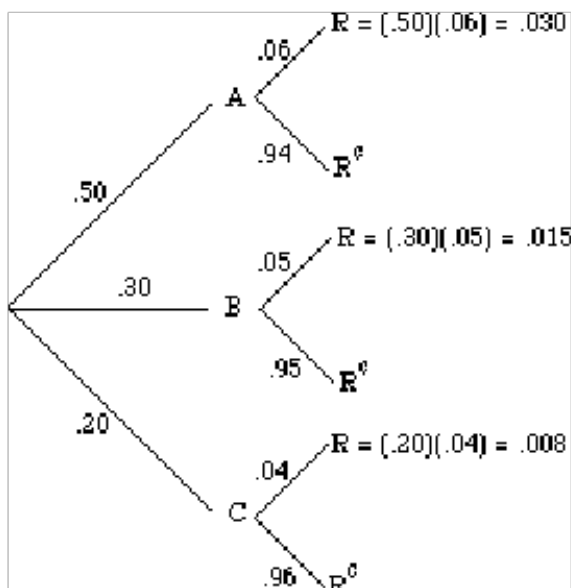

Figure 15.4

The probability $P(A | R)$, for example, is a fraction whose denominator is the sum of all probabilities of all branches of the tree that result in an appliance that needs repair before the warranty expires, and the numerator is the branch that is associated with Manufacturer A. $P(B | R)$ and $P(C | R)$ are found in the same way. We list both as follows:

$$P(A | R) = \frac{.030}{(.030)+(.015)+(.008)} = \frac{.030}{.053} = .566$$

$$P(B | R) = \frac{.015}{.053} = .283 \text{ and } P(C | R) = \frac{.008}{.053} = .151.$$

Alternatively, using Bayes' formula,

$$\begin{aligned} P(A | R) &= \frac{P(A)P(R|A)}{P(A)P(R|A)+P(B)P(R|B)+P(C)P(R|C)} \\ &= \frac{.030}{(.030)+(.015)+(.008)} = \frac{.030}{.053} = .566 \end{aligned} \tag{15.8}$$

$P(B | R)$ and $P(C | R)$ can be determined in the same manner.

Example 15.10

There are five Jacy's department stores in San Jose. The distribution of number of employees by gender is given in the table below.

Store Number	Number of Employees	Percent of Women Employees
1	300	.40
2	150	.65
3	200	.60
4	250	.50
5	100	.70
	Total=1000	

Table 15.2

If an employee chosen at random is a woman, what is the probability that the employee works at store III?

Solution

Let $k = 1, 2, \dots, 5$ be the event that the employee worked at store k , and W be the event that the employee is a woman. Since there are a total of 1000 employees at the five stores,

$$P(1) = .30 \quad P(2) = .15 \quad P(3) = .20 \quad P(4) = .25 \quad P(5) = .10 \quad (15.9)$$

Using Bayes' formula,

$$\begin{aligned} P(3, |, W) &= \frac{P(3)P(W, |, 3)}{P(1)P(W, |, 1) + P(2)P(W, |, 2) + P(3)P(W, |, 3) + P(4)P(W, |, 4) + P(5)P(W, |, 5)} \\ &= \frac{(.20)(.60)}{(.30)(.40) + (.15)(.65) + (.20)(.60) + (.25)(.50) + (.10)(.70)} \\ &= .2254 \end{aligned} \quad (15.10)$$

15.4 Expected Value

An expected gain or loss in a game of chance is called **Expected Value**. The concept of expected value is closely related to a *weighted average*. Consider the following situations.

1. Suppose you and your friend play a game that consists of rolling a die. Your friend offers you the following deal: If the die shows any number from 1 to 5, he will pay you the face value of the die in dollars, that is, if the die shows a 4, he will pay you \$4. But if the die shows a 6, you will have to pay him \$18.

Before you play the game you decide to find the expected value. You analyze as follows.

Since a die will show a number from 1 to 6, with an equal probability of $1/6$, your chance of winning \$1 is $1/6$, winning \$2 is $1/6$, and so on up to the face value of 5. But if the die shows a 6, you will lose \$18. You write the expected value.

$$E = \$1(1/6) + \$2(1/6) + \$3(1/6) + \$4(1/6) + \$5(1/6) - \$18(1/6) = -\$0.50$$

This means that every time you play this game, you can expect to lose 50 cents. In other words, if you play this game 100 times, theoretically you will lose \$50. Obviously, it is not to your interest to play.

2. Suppose of the ten quizzes you took in a course, on eight quizzes you scored 80, and on two you scored 90. You wish to find the average of the ten quizzes. The average is

$$A = \frac{(80)(8) + (90)(2)}{10} = (80)\frac{8}{10} + (90)\frac{2}{10} = 82 \quad (15.11)$$

It should be observed that it will be incorrect to take the average of 80 and 90 because you scored 80 on eight quizzes, and 90 on only two of them. Therefore, you take a "weighted average" of 80 and 90. That is, the average of 8 parts of 80 and 2 parts of 90, which is 82.

In the first situation, to find the expected value, we multiplied each payoff by the probability of its occurrence, and then added up the amounts calculated for all possible cases. In the second part of p. 259, if we consider our test score a payoff, we did the same. This leads us to the following definition.

Definition 15.1: Expected Value

If an experiment has the following probability distribution,

Payoff	x_1	x_2	x_3	\cdots	x_n
Probability	$p(x_1)$	$p(x_2)$	$p(x_3)$	\cdots	$p(x_n)$

Table 15.3

then the expected value of the experiment is

$$\text{Expected Value} = x_1p(x_1) + x_2p(x_2) + x_3p(x_3) + \cdots + x_np(x_n)$$

Example 15.11

In a town, 10% of the families have three children, 60% of the families have two children, 20% of the families have one child, and 10% of the families have no children. What is the expected number of children to a family?

Solution

We list the information in the following table.

Number of Children	3	2	1	0
Probability	.10	.60	.20	.10

Table 15.4

$$\text{Expected Value} = x_1p(x_1) + x_2p(x_2) + x_3p(x_3) + x_4p(x_4) \quad (15.12)$$

$$E = 3(.10) + 2(.60) + 1(.20) + 0(.10) = 1.7 \quad (15.13)$$

So on average, there are 1.7 children to a family.

Example 15.12

To sell an average house, a real estate broker spends \$1200 for advertisement expenses. If the house sells in three months, the broker makes \$8,000. Otherwise, the broker loses the listing. If there is a 40% chance that the house will sell in three months, what is the expected payoff for the real estate broker?

Solution

The broker makes \$8,000 with a probability of .40, but he loses \$1200 whether the house sells or not.

$$E = (\$8,000)(.40) - (\$1200) = \$2,000.$$

Alternatively, the broker makes \$(8000 - 1200) with a probability of .40, but loses \$1200 with a probability of .60. Therefore,

$$E = (\$6800)(.40) - (\$1200)(.60) = \$2,000.$$

Example 15.13

In a town, the attendance at a football game depends on the weather. On a sunny day the attendance is 60,000, on a cold day the attendance is 40,000, and on a stormy day the attendance is 30,000. If for the next football season, the weatherman has predicted that 30% of the days will be sunny, 50% of the days will be cold, and 20% days will be stormy, what is the expected attendance for a single game?

Solution

Using the expected value formula, we get

$$e = (60,000)(.30) + (40,000)(.50) + (30,000)(.20) = 44,000. \quad (15.14)$$

Example 15.14

A lottery consists of choosing 6 numbers from a total of 51 numbers. The person who matches all six numbers wins \$2 million. If the lottery ticket costs \$1, what is the expected payoff?

Solution

Since there are ${}_{51}C_6 = 18,009,460$ combinations of six numbers from a total of 51 numbers, the chance of choosing the winning number is 1 out of 18,009,460. So the expected payoff is

$$E = (\$2 \text{ million}) \left(\frac{1}{18009460} \right) - \$1 = \$0.89 \quad (15.15)$$

This means that every time a person spends \$1 to buy a ticket, he or she can expect to lose 89 cents.

15.5 Probability Using Tree Diagrams

As we have already seen, tree diagrams play an important role in solving probability problems. A tree diagram helps us not only visualize, but also list all possible outcomes in a systematic fashion. Furthermore, when we list various outcomes of an experiment and their corresponding probabilities on a tree diagram, we

gain a better understanding of when probabilities are multiplied and when they are added. The meanings of the words *and* and *or* become clear when we learn to multiply probabilities horizontally across branches, and add probabilities vertically down the tree.

Although tree diagrams are not practical in situations where the possible outcomes become large, they are a significant tool in breaking the problem down in a schematic way. We consider some examples that may seem difficult at first, but with the help of a tree diagram, they can easily be solved.

Example 15.15

A person has four keys and only one key fits to the lock of a door. What is the probability that the locked door can be unlocked in at most three tries?

Solution

Let U be the event that the door has been unlocked and L be the event that the door has not been unlocked. We illustrate with a tree diagram.

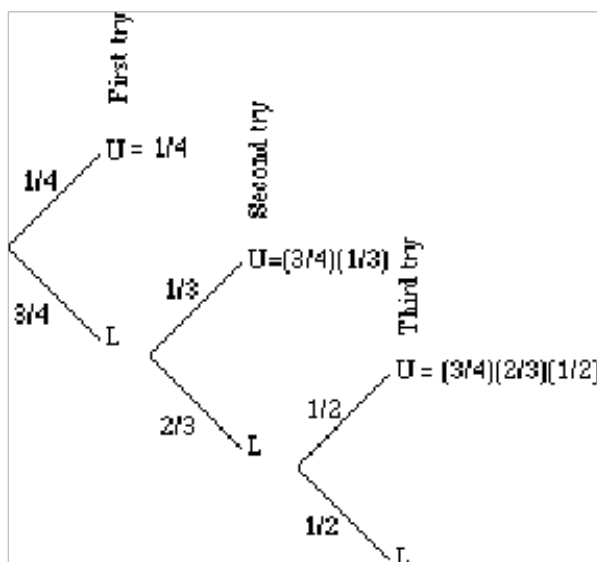

Figure 15.5

$$\text{The probability of unlocking the door in the first try} = 1/4 \quad (15.16)$$

$$\text{The probability of unlocking the door in the second try} = (3/4)(1/3) = 1/4 \quad (15.17)$$

$$\text{The probability of unlocking the door in the third try} = (3/4)(2/3)(1/2) = 1/4 \quad (15.18)$$

Therefore, the probability of unlocking the door in at most three tries = $1/4 + 1/4 + 1/4 = 3/4$

Example 15.16

A jar contains 3 black and 2 white marbles. We continue to draw marbles one at a time until two black marbles are drawn. If a white marble is drawn, the outcome is recorded and the marble is put back in the jar before drawing the next marble. What is the probability that we will get exactly two black marbles in at most three tries?

Solution

We illustrate using a tree diagram.

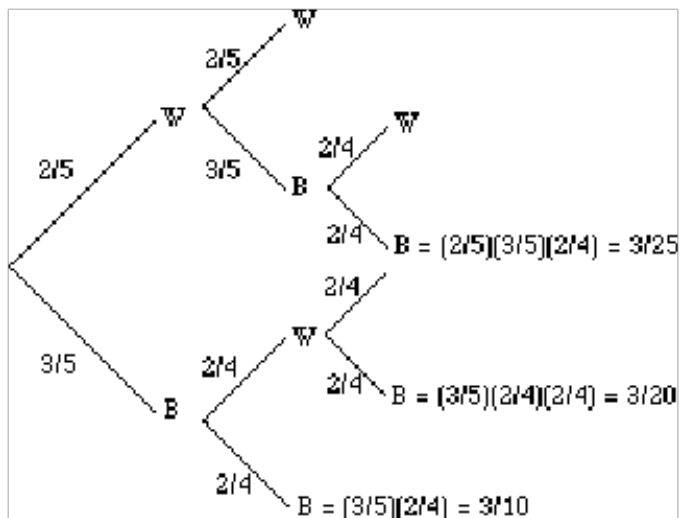

Figure 15.6

The probability that we will get two black marbles in the first two tries is listed adjacent to the lowest branch, and it = $\frac{3}{10}$

The probability of getting first black, second white, and third black = $\frac{3}{20}$

Similarly, the probability of getting first white, second black, and third black = $\frac{3}{25}$

Therefore, the probability of getting exactly two black marbles in at most three tries = $\frac{3}{10} + \frac{3}{20} + \frac{3}{25} = \frac{57}{100}$

Example 15.17

A circuit consists of three resistors: resistor R_1 , resistor R_2 , and resistor R_3 , joined in a series. If one of the resistors fails, the circuit stops working. If the probability that resistors R_1 , R_2 , or R_3 will fail is .07, .10, and .08, respectively, what is the probability that at least one of the resistors will fail?

Solution

Clearly, the that at least one of the resistors fails = $1 -$ none of the resistors fails.

It is quite easy to find the probability of the event that none of the resistors fails. We don't even need to draw a tree because we can visualize the only branch of the tree that assures this outcome.

The probabilities that R_1 , R_2 , R_3 will not fail are .93, .90, and .92 respectively. Therefore, the probability that none of the resistors fails = $(.93)(.90)(.92) = .77$.

Thus, the probability that at least one of them will fail = $1 - .77 = .23$.

Chapter 16

More Probability: Homework¹

16.1 BINOMIAL PROBABILITY

Do the following problems using the binomial probability formula.

Exercise 16.1 *(Solution on p. 273.)*

A coin is tossed ten times. Find the probability of getting six heads and four tails.

Exercise 16.2

A family has three children. Find the probability of having one boy and two girls.

Exercise 16.3 *(Solution on p. 273.)*

What is the probability of getting three aces(ones) if a die is rolled five times?

Exercise 16.4

A baseball player has a .250 batting average. What is the probability that he will have three hits in five times at bat?

Exercise 16.5 *(Solution on p. 273.)*

A basketball player has an 80% chance of sinking a basket on a free throw. What is the probability that he will sink at least three baskets in five free throws?

Exercise 16.6

With a new flu vaccination, 85% of the people in the high risk group can go through the entire winter without contracting the flu. In a group of six people who were vaccinated with this drug, what is the probability that at least four will not get the flu?

Exercise 16.7 *(Solution on p. 273.)*

A transistor manufacturer has known that 5% of the transistors produced are defective. What is the probability that a batch of twenty five will have two defective?

Exercise 16.8

It has been determined that only 80% of the people wear seat belts. If a police officer stops a car with four people, what is the probability that at least one person will not be wearing a seat belt?

Exercise 16.9 *(Solution on p. 273.)*

What is the probability that a family of five children will have at least three boys?

Exercise 16.10

What is the probability that a toss of four coins will yield at most two heads?

¹This content is available online at <http://cnx.org/content/m38660/1.1/>.

Exercise 16.11*(Solution on p. 273.)*

A telemarketing executive has determined that for a particular product, 20% of the people contacted will purchase the product. If 10 people are contacted, what is the probability that at most 2 will buy the product?

Exercise 16.12

To the problem: "Five cards are dealt from a deck of cards, find the probability that three of them are kings," the following incorrect answer was offered by a student.

$$5C3(1/13)^3(12/13)^2 \quad (16.1)$$

What change would you make in the wording of the problem for the given answer to be correct?

16.2 BAYES' FORMULA

Use both tree diagrams and Bayes' formula to solve the following problems.

Exercise 16.13*(Solution on p. 273.)*

Jar I contains five red and three white marbles, and Jar II contains four red and two white marbles. A jar is picked at random and a marble is drawn. Draw a tree diagram below, and find the following probabilities.

- $P(\text{marble is red})$
- $P(\text{It came from Jar II given that the marble drawn is white})$
- $P(\text{Red} \mid \text{Jar I})$

Exercise 16.14

In Mr. Symons' class, if a person does his homework most days, his chance of passing the course is 90%. On the other hand, if a person does not do his homework most days his chance of passing the course is only 20%. Mr. Symons claims that 80% of his students do their homework on a regular basis. If a student is chosen at random from Mr. Symons' class, find the following probabilities.

- $P(\text{the student passes the course})$
- $P(\text{the student did homework} \mid \text{the student passes the course})$
- $P(\text{the student passes the course} \mid \text{the student did homework})$

Exercise 16.15*(Solution on p. 273.)*

A city has 60% Democrats, and 40% Republicans. In the last mayoral election, 60% of the Democrats voted for their Democratic candidate while 95% of the Republicans voted for their candidate. Which party's mayor runs city hall?

Exercise 16.16

In a certain population of 48% men and 52% women, 56% of the men and 8% of the women are color-blind.

- What percent of the people are color-blind?
- If a person is found to be color-blind, what is the probability that the person is a male?

Exercise 16.17*(Solution on p. 273.)*

A test for a certain disease gives a positive result 95% of the time if the person actually carries the disease. However, the test also gives a positive result 3% of the time when the individual is not carrying the disease. It is known that 10% of the population carries the disease. If the test is positive for a person, what is the probability that he or she has the disease?

Exercise 16.18

A person has two coins: a fair coin and a two-headed coin. A coin is selected at random, and tossed. If the coin shows a head, what is the probability that the coin is fair?

Exercise 16.19*(Solution on p. 273.)*

A computer company buys its chips from three different manufacturers. Manufacturer I provides 60% of the chips and is known to produce 5% defective; Manufacturer II supplies 30% of the chips and makes 4% defective; while the rest are supplied by Manufacturer III with 3% defective chips. If a chip is chosen at random, find the following probabilities.

- P (the chip is defective)
- P (it came from Manufacturer II | the chip is defective)
- P (the chip is defective | it came from manufacturer III)

Exercise 16.20

Lincoln Union High School District is made up of three high schools: Monterey, Fremont, and Kennedy, with an enrollment of 500, 300, and 200, respectively. On a given day, the percentage of students absent at Monterey High School is 6%, at Fremont 4%, and at Kennedy 5%. If a student is chosen at random, find the following probabilities. Hint: Convert the enrollments into percentages.

- P (the student is absent)
- P (the student came from Kennedy | the student is absent)
- P (the student is absent | the student came from Fremont)

16.3 EXPECTED VALUE

Do the following problems using the expected value concepts learned in this section,

Exercise 16.21*(Solution on p. 273.)*

You are about to make an investment which gives you a 30% chance of making \$60,000 and 70% chance of losing \$ 30,000. Should you invest? Explain.

Exercise 16.22

In a town, 40% of the men and 30% of the women are overweight. If the town has 46% men and 54% women, what percent of the people are overweight?

Exercise 16.23*(Solution on p. 273.)*

A game involves rolling a Korean die (4 faces). If a one, two, or three shows, the player receives the face value of the die in dollars, but if a four shows, the player is obligated to pay \$4. What is the expected value of the game?

Exercise 16.24

A game involves rolling a single die. One receives the face value of the die in dollars. How much should one be willing to pay to roll the die to make the game fair?

Exercise 16.25*(Solution on p. 273.)*

In a European country, 20% of the families have three children, 40% have two children, 30% have one child, and 10% have no children. On average, how many children are there to a family?

Exercise 16.26

A game involves drawing a single card from a standard deck. One receives 60 cents for an ace, 30 cents for a king, and 5 cents for a red card that is neither an ace nor a king. If the cost of each draw is 10 cents, should one play? Explain.

Exercise 16.27*(Solution on p. 273.)*

Hillview Church plans to raise money by raffling a television worth \$500. A total of 3000 tickets are sold at \$1 each. Find the expected value of the winnings for a person who buys a ticket in the raffle.

Exercise 16.28

During her four years at college, Niki received A's in 30% of her courses, B's in 60% of her courses, and C's in the remaining 10%. If $A = 4$, $B = 3$, and $C = 2$, find her grade point average.

Exercise 16.29*(Solution on p. 273.)*

Attendance at a Stanford football game depends upon which team Stanford is playing against. If the game is against U. C. Berkeley, the attendance will be 70,000; if it is against another California team, it will be 40,000; and if it is against an out of state team, it will be 30,000. If the probability of playing against U. C. Berkeley is 10%, against a California team 50%, and against an out of state team 40%, how many fans are expected to attend a game?

Exercise 16.30

A Texas oil drilling company has determined that it costs \$25,000 to sink a test well. If oil is hit, the revenue for the company will be \$500,000. If natural gas is found, the revenue will be \$150,000. If the probability of hitting oil is 3% and of hitting gas is 6%, find the expected value of sinking a test well.

Exercise 16.31*(Solution on p. 273.)*

A \$1 lottery ticket offers a grand prize of \$10,000; 10 runner-up prizes each paying \$1000; 100 third-place prizes each paying \$100; and 1,000 fourth-place prizes each paying \$10. Find the expected value of entering this contest if 1 million tickets are sold.

Exercise 16.32

Assume that for the next heavyweight fight the odds of Mike Tyson winning are 15 to 2. A gambler bets \$10 that Mike Tyson will lose. If Mike Tyson loses, how much can the gambler hope to receive?

16.4 PROBABILITY USING TREE DIAGRAMS

Use a tree diagram to solve the following problems.

Exercise 16.33*(Solution on p. 273.)*

Suppose you have five keys and only one key fits to the lock of a door. What is the probability that you can open the door in at most three tries?

Exercise 16.34

A coin is tossed until a head appears. What is the probability that a head will appear in at most three tries?

Exercise 16.35*(Solution on p. 273.)*

A basketball player has an 80% chance of making a basket on a free throw. If he makes the basket on the first throw, he has a 90% chance of making it on the second. However, if he misses on the first try, there is only a 70% chance he will make it on the second. If he gets two free throws, what is the probability that he will make at least one of them?

Exercise 16.36

You are to play three games. In the first game, you draw a card, and you win if the card is a heart. In the second game, you toss two coins, and you win if one head and one tail are shown. In the third game, two dice are rolled and you win if the sum of the dice is 7 or 11. What is the probability that you win all three games? What is the probability that you win exactly two games?

Exercise 16.37*(Solution on p. 273.)*

John's car is in the garage, and he has to take a bus to get to school. He needs to make all three connections on time to get to his class. If the chance of making the first connection on time is 80%, the second 80%, and the third 70%, what is the chance that John will make it to his class on time?

Exercise 16.38

For a real estate exam the probability of a person passing the test on the first try is .70. The probability that a person who fails on the first try will pass on each of the successive attempts is .80. What is the probability that a person passes the test in at most three attempts?

Exercise 16.39*(Solution on p. 273.)*

On a Christmas tree with lights, if one bulb goes out, the entire string goes out. If there are twelve bulbs on a string, and the probability of any one going out is .04, what is the probability that the string will not go out?

Exercise 16.40

The Long Life Light Bulbs claims that the probability that a light bulb will go out when first used is 15%, but if it does not go out on the first use the probability that it will last the first year is 95%, and if it lasts the first year, there is a 90% probability that it will last two years. What is the probability that a new bulb will last two years?

Exercise 16.41*(Solution on p. 273.)*

A die is rolled until an ace (1) shows. What is the probability that an ace will show on the fourth try?

Exercise 16.42

If there are four people in a room, what is the probability that no two have the same birthday?

Exercise 16.43*(Solution on p. 274.)*

Dan forgets to set his alarm 60% of the time. If he hears the alarm, he turns it off and goes back to sleep 20% of the time, and even if he does wake up on time, he is late getting ready 30% of the time. What is the probability that Dan will be late to school?

Exercise 16.44

It has been estimated that 20% of the athletes take some type of drugs. A drug test is 90% accurate, that is, the probability of a false-negative is 10%. Furthermore, for this test the probability of a false-positive is 20%. If an athlete tests positive, what is the probability that he is a drug user?

16.5 CHAPTER REVIEW

Exercise 16.45*(Solution on p. 274.)*

A coin is tossed five times. Find the following

- $P(2 \text{ heads and } 3 \text{ tails})$
- $P(\text{at least } 4 \text{ tails})$

Exercise 16.46*(Solution on p. 274.)*

A dandruff shampoo helps 80% of the people who use it. If 10 people apply this shampoo to their hair, what is the probability that 6 will be dandruff free?

Exercise 16.47*(Solution on p. 274.)*

A baseball player has a .250 batting average. What is the probability that he will have 2 hits in 4 times at bat?

Exercise 16.48*(Solution on p. 274.)*

Suppose that 60% of the voters in California intend to vote Democratic in the next election. If we choose five people at random, what is the probability that at least four will vote Democratic?

Exercise 16.49*(Solution on p. 274.)*

A basketball player has a .70 chance of sinking a basket on a free throw. What is the probability that he will sink at least 4 baskets in six shots?

Exercise 16.50*(Solution on p. 274.)*

During an archery competition, Stan has a 0.8 chance of hitting a target. If he shoots three times, what is the probability that he will hit the target all three times?

Exercise 16.51*(Solution on p. 274.)*

A company finds that one out of four new applicants overstate their work experience. If ten people apply for a job at this company, what is the probability that at most two will overstate their work experience?

Exercise 16.52*(Solution on p. 274.)*

A missile has a 70% chance of hitting a target. How many missiles should be fired to make sure that the target is destroyed with a probability of .99 or more?

Exercise 16.53*(Solution on p. 274.)*

Jar I contains 4 red and 5 white marbles, and Jar II contains 2 red and 4 white marbles. A jar is picked at random and a marble is drawn. Draw a tree diagram and find,

- P (Marble is red)
- P (It is white given that it came from Jar II)
- P (It came from Jar II knowing that the marble drawn is white)

Exercise 16.54*(Solution on p. 274.)*

Suppose a test is given to determine if a person is infected with HIV. If a person is infected with HIV, the test will detect it in 90% of the cases; and if the person is not infected with HIV, the test will show a positive result 3% of the time. If we assume that 2% of the population is actually infected with HIV, what is the probability that a person obtaining a positive result is actually infected with HIV?

Exercise 16.55*(Solution on p. 274.)*

A movie and music rental store's inventory consists of 70% movie videos and 30% music videos. Twenty percent of the movie videos and 10% of the music videos are old and need replacement. If a video chosen at random is found to be old, what is the probability that it is a movie video?

Exercise 16.56*(Solution on p. 274.)*

Two machines make all the products in a factory, with the first machine making 30% of the products and the second 70%. The first machine makes defective products 3% of the time and the second machine 5% of the time.

- Overall what percent of the products made are defective?
- If a defective product is found, what is the probability that it was made on the second machine?
- If it was made on the second machine, what is the probability that it is defective?

Exercise 16.57*(Solution on p. 274.)*

An instructor in a finite math course estimates that a student who does his homework has a 90% of chance of passing the course, while a student who does not do the homework has only a 20% chance of passing the course. It has been determined that 60% of the students in a large class do their homework.

- What percent of all the students will pass?
- If a student passes, what is the probability that he did the homework?

Exercise 16.58*(Solution on p. 274.)*

Cars are being produced by three factories. Factory I produces 10% of the cars and it is known to produce 2% defective cars, Factory II produces 20% of the cars and it produces 3% defective cars, and Factory III produces 70% of the cars and 4% of those are defective. A car is chosen at random. Find the following probabilities:

- $P(\text{The car is defective})$
- $P(\text{It came from Factory III} \mid \text{the car is defective})$

Exercise 16.59*(Solution on p. 275.)*

A multiple-choice test has five choices to a question and only one of them is correct. If a student does his homework, he has a 90% of chance of getting the correct answer. Suppose there is a 70% chance that the student will do his homework, what will his test score be on this test?

Exercise 16.60*(Solution on p. 275.)*

A game involves rolling a pair of dice. One receives the sum of the face value of both dice in dollars. How much should one be willing to pay to roll the dice to make the game fair?

Exercise 16.61*(Solution on p. 275.)*

A roulette wheel consists of numbers 1 through 36, 0, and 00. If the wheel comes up an odd number you win a dollar, otherwise you lose a dollar. If you play the game ten times, what is your expectation?

Exercise 16.62*(Solution on p. 275.)*

A student takes a 100-question multiple-choice exam in which there are four choices to each question. If the student is just guessing the answers, what score can he expect?

Exercise 16.63*(Solution on p. 275.)*

Mr. Shaw invests 50% of his money in stocks, 30% in mutual funds, and the remaining 20% in bonds. If the annual yield from stocks is 10%, from mutual funds 12%, and from bonds 7%, what percent return can Mr. Shaw expect on his money?

Exercise 16.64*(Solution on p. 275.)*

An insurance company is planning to insure a group of surgeons against medical malpractice. Its research shows that two surgeons in every fifteen are involved in a medical malpractice suit each year where the average award to the victim is \$450,000. How much minimum annual premium should the insurance company charge each doctor?

Exercise 16.65*(Solution on p. 275.)*

In an evening finite math class of 30 students, it was discovered that 5 students were of age 20, 8 students were about 25 years old, 10 students were close to 30, 4 students were 35, 2 students were 40 and one student 55. What is the average age of a student in this class?

Exercise 16.66*(Solution on p. 275.)*

Jar I contains 4 marbles of which one is red, and Jar II contains 6 marbles of which 3 are red. Katy selects a jar and then chooses a marble. If the marble is red, she gets paid 3 dollars, otherwise she loses a dollar. If she plays this game ten times, what is her expected payoff?

Exercise 16.67*(Solution on p. 275.)*

Jar I contains 1 red and 3 white, and Jar II contains 2 red and 3 white marbles. A marble is drawn from Jar I and put in Jar II. Now if one marble is drawn from Jar II, what is the probability that it is a red marble?

Exercise 16.68*(Solution on p. 275.)*

Let us suppose there are three traffic lights between your house and the school. The chance of finding the first light green is 60%, the second 50%, and the third 30%. What is the probability that on your way to school, you will find at least two lights green?

Exercise 16.69*(Solution on p. 275.)*

Sonya has just earned her law degree and is planning to take the bar exam. If her chance of passing the bar exam is 65% on each try, what is the probability that she will pass the exam in at least three tries?

Exercise 16.70*(Solution on p. 275.)*

Every time Ken Griffey is at bat, his probability of getting a hit is .3, his probability of walking is .1, and his probability of being struck out is .4. If he is at bat three times, what is the probability that he will get two hits and one walk?

Exercise 16.71*(Solution on p. 275.)*

Jar I contains 4 marbles of which none are red, and Jar II contains 6 marbles of which 4 are red. Juan first chooses a jar and then from it he chooses a marble. After the chosen marble is replaced, Mary repeats the same experiment. What is the probability that at least one of them chooses a red marble?

Exercise 16.72*(Solution on p. 275.)*

Andre and Pete are two tennis players with equal ability. Andre makes the following offer to Pete: We will not play more than four games, and anytime I win more games than you, I am declared a winner and we stop. Draw a tree diagram and determine Andre's probability of winning.

Solutions to Exercises in Chapter 16

Solutions to More Probability: Homework

Solution to Exercise 16.1 (p. 265)

0.2051

Solution to Exercise 16.3 (p. 265)

0.0322

Solution to Exercise 16.5 (p. 265)

0.9421

Solution to Exercise 16.7 (p. 265)

0.2305

Solution to Exercise 16.9 (p. 265)

0.5

Solution to Exercise 16.11 (p. 266)

0.6778

Solution to Exercise 16.13 (p. 266)

a. 0.6458

b. 0.4706

c. 0.625

Solution to Exercise 16.15 (p. 266)

The Republican Party

Solution to Exercise 16.17 (p. 266)

0.7787

Solution to Exercise 16.19 (p. 267)

a. 0.045

b. 0.2667

c. 0.03

Solution to Exercise 16.21 (p. 267)

No; You can expect to lose \$3,000.

Solution to Exercise 16.23 (p. 267)

50 cents

Solution to Exercise 16.25 (p. 267)

1.7

Solution to Exercise 16.27 (p. 268)

-83 cents

Solution to Exercise 16.29 (p. 268)

39,000

Solution to Exercise 16.31 (p. 268)

-96 cents

Solution to Exercise 16.33 (p. 268)

3/5

(16.2)

Solution to Exercise 16.35 (p. 268)

0.94

Solution to Exercise 16.37 (p. 269)

0.448

Solution to Exercise 16.39 (p. 269)

0.6127

Solution to Exercise 16.41 (p. 269)

125/1296

(16.3)

Solution to Exercise 16.43 (p. 269)
0.776

Solution to Exercise 16.45 (p. 269)

- a. 0.3125
- b. 0.1875

Solution to Exercise 16.46 (p. 269)
0.088

Solution to Exercise 16.47 (p. 269)
0.21094

Solution to Exercise 16.48 (p. 269)
0.33696

Solution to Exercise 16.49 (p. 270)
0.74432

Solution to Exercise 16.50 (p. 270)
0.512

Solution to Exercise 16.51 (p. 270)
0.52559

Solution to Exercise 16.52 (p. 270)
4

Solution to Exercise 16.53 (p. 270)

- a. 7/18
- b. 2/3
- c. 6/11

Solution to Exercise 16.54 (p. 270)
0.37975

Solution to Exercise 16.55 (p. 270)

14/17

(16.4)

Solution to Exercise 16.56 (p. 270)

- a. 4.4%
- b. 35/44
- c. 0.05

Solution to Exercise 16.57 (p. 270)

- a. 0.62
- b. 54/62

Solution to Exercise 16.58 (p. 271)

- a. 0.036
- b. 28/36

Solution to Exercise 16.59 (p. 271)

69%

Solution to Exercise 16.60 (p. 271)

\$7

Solution to Exercise 16.61 (p. 271)

-\$5.26

Solution to Exercise 16.62 (p. 271)

25

Solution to Exercise 16.63 (p. 271)

10%

Solution to Exercise 16.64 (p. 271)

\$60,000

Solution to Exercise 16.65 (p. 271)

29.167

Solution to Exercise 16.66 (p. 271)

\$5

Solution to Exercise 16.67 (p. 271)

3/8

(16.5)

Solution to Exercise 16.68 (p. 271)

0.45

Solution to Exercise 16.69 (p. 272)

0.957125

Solution to Exercise 16.70 (p. 272)

0.027

Solution to Exercise 16.71 (p. 272)

5/9

(16.6)

Solution to Exercise 16.72 (p. 272)

5/8

(16.7)

Chapter 17

Markov Chains¹

17.1 Chapter Overview

In this chapter, you will learn to:

1. Write transition matrices for Markov Chain problems.
2. Find the long term trend for a Regular Markov Chain.
3. Solve and interpret Absorbing Markov Chains.

17.2 Markov Chains

We will now study stochastic processes, experiments in which the outcomes of events depend on the previous outcomes. Such a process or experiment is called a **Markov Chain** or **Markov process**. The process was first studied by a Russian mathematician named Andrei A. Markov in the early 1900s.

A small town is served by two telephone companies, Mama Bell and Papa Bell. Due to their aggressive sales tactics, each month 40% of Mama Bell customers switch to Papa Bell, that is, the other 60% stay with Mama Bell. On the other hand, 30% of the Papa Bell customers switch to Mama Bell. The above information can be expressed in a matrix which lists the probabilities of going from one state into another state. This matrix is called a **transition matrix**.

		Next Month	
		Mama Bell	Papa Bell
First Month	Mama Bell	.60	.40
	Papa Bell	.30	.70

Figure 17.1

The reader should observe that a transition matrix is always a square matrix because all possible states must have both rows and columns. All entries in a transition matrix are non-negative as they represent probabilities. Furthermore, since all possible outcomes are considered in the Markov process, the sum of the row entries is always 1.

¹This content is available online at <<http://cnx.org/content/m18909/1.2/>>.

Example 17.1

Professor Symons either walks to school, or he rides his bicycle. If he walks to school one day, then the next day, he will walk or cycle with equal probability. But if he bicycles one day, then the probability that he will walk the next day is $1/4$. Express this information in a transition matrix.

Solution

We obtain the following transition matrix by properly placing the row and column entries. Note that if, for example, Professor Symons bicycles one day, then the probability that he will walk the next day is $1/4$, and therefore, the probability that he will bicycle the next day is $3/4$.

		Next Day	
		Walk	Bicycle
First Day	Walk	$1/2$	$1/2$
	Bicycle	$1/4$	$3/4$

Figure 17.2

Example 17.2

In Example 17.1, if it is assumed that the first day is Monday, write a matrix that gives probabilities of a transition from Monday to Wednesday.

Solution

Let W denote that Professor Symons walks and B denote that he rides his bicycle.

We use the following tree diagram to compute the probabilities.

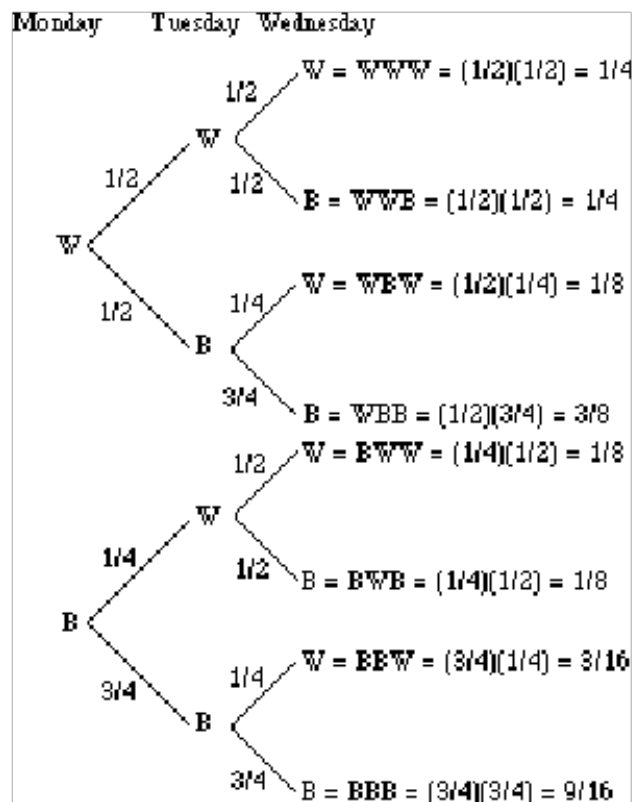

Figure 17.3

The probability that Professor Symons walked on Wednesday given that he walked on Monday can be found from the tree diagram, as listed below.

$$P(\text{Walked Wednesday} \mid \text{Walked Monday}) = P(WWW) + P(WBW) = 1/4 + 1/8 = 3/8.$$

$$P(\text{Bicycled Wednesday} \mid \text{Walked Monday}) = P(WWB) + P(WBB) = 1/4 + 3/8 = 5/8.$$

$$P(\text{Walked Wednesday} \mid \text{Bicycled Monday}) = P(BWW) + P(BBW) = 1/8 + 3/16 = 3/5/16.$$

$$P(\text{Bicycled Wednesday} \mid \text{Bicycled Monday}) = P(BWB) + P(BBB) = 1/8 + 9/16 = 11/16.$$

We represent the results in the following matrix.

		Wednesday	
		Walk	Bicycle
Monday	Walk	3/8	5/8
	Bicycle	3/16	11/16

Figure 17.4

Alternately, this result can be obtained by squaring the original transition matrix.

We list both the original transition matrix T and T^2 as follows:

$$T = \begin{bmatrix} 1/2 & 1/2 \\ 1/4 & 3/4 \end{bmatrix} \quad (17.1)$$

$$T^2 = \begin{bmatrix} 1/2 & 1/2 \\ 1/4 & 3/4 \end{bmatrix} \begin{bmatrix} 1/2 & 1/2 \\ 1/4 & 3/4 \end{bmatrix} = \begin{bmatrix} 1/4 + 1/8 & 1/4 + 3/8 \\ 1/8 + 3/16 & 1/8 + 9/16 \end{bmatrix} = \begin{bmatrix} 3/8 & 5/8 \\ 5/16 & 11/16 \end{bmatrix} \quad (17.2)$$

The reader should compare this result with the probabilities obtained from the tree diagram.

Consider the following case, for example,

$$P(\text{Walked Wednesday} \mid \text{Bicycled Monday}) = P(\text{BWW}) + P(\text{BBW}) = 1/8 + 3/16 = 5/16. \quad (17.3)$$

It makes sense because to find the probability that Professor Symons will walk on Wednesday given that he bicycled on Monday, we sum the probabilities of all paths that begin with B and end in W . There are two such paths, and they are BWW and BBW.

Example 17.3

The transition matrix for Example 17.1 is given below.

		Tuesday	
		Walk	Bicycle
Monday	Walk	1/2	1/2
	Bicycle	1/4	3/4

Figure 17.5

Write the transition matrix from a) Monday to Thursday, b) Monday to Friday.

Solution

In writing a transition matrix from Monday to Thursday, we are moving from one state to another in three steps. That is, we need to compute T^3 .

$$T^3 = \begin{bmatrix} 11/32 & 21/32 \\ 21/64 & 43/64 \end{bmatrix} \quad (17.4)$$

b) To find the transition matrix from Monday to Friday, we are moving from one state to another in 4 steps. Therefore, we compute T^4 .

$$T^4 = \begin{bmatrix} 43/128 & 85/128 \\ 85/256 & 171/256 \end{bmatrix} \quad (17.5)$$

It is important that the student is able to interpret the above matrix correctly. For example, the entry $85/128$, states that if Professor Symons walked to school on Monday, then there is $85/128$ probability that he will bicycle to school on Friday.

There are certain Markov chains that tend to stabilize in the long run, and they are the subject of Section 17.3 (Regular Markov Chains). It so happens that the transition matrix we have used in all the above examples is just such a Markov chain. The next example deals with the long term trend or steady-state situation for that matrix.

Example 17.4

Suppose Professor Symons continues to walk and bicycle according to the transition matrix given in Example 17.1. In the long run, how often will he walk to school, and how often will he bicycle?

Solution

As mentioned earlier, as we take higher and higher powers of our matrix T , it should stabilize.

$$T^5 = \begin{bmatrix} .333984 & .666015 \\ .333007 & .666992 \end{bmatrix} \quad (17.6)$$

$$T^{10} = \begin{bmatrix} .3333397 & .6666603 \\ .3333301 & .6666698 \end{bmatrix} \quad (17.7)$$

$$T^{20} = \begin{bmatrix} 1/3 & 2/3 \\ 1/3 & 2/3 \end{bmatrix} \quad (17.8)$$

Therefore, in the long run, Professor Symons will walk to school $1/3$ of the time and bicycle $2/3$ of the time.

When this happens, we say that the system is in steady-state or state of equilibrium. In this situation, all row vectors are equal. If the original matrix is an n by n matrix, we get n vectors that are all the same. We call this vector a **fixed probability vector** or the **equilibrium vector** E . In the above problem, the fixed probability vector E is $\begin{bmatrix} 1/3 & 2/3 \end{bmatrix}$. Furthermore, if the equilibrium vector E is multiplied by the original matrix T , the result is the equilibrium vector E . That is,

$$ET = E \quad (17.9)$$

or,

$$\begin{bmatrix} 1/3 & 2/3 \end{bmatrix} \begin{bmatrix} 1/2 & 1/2 \\ 1/4 & 3/4 \end{bmatrix} = \begin{bmatrix} 1/3 & 2/3 \end{bmatrix} \quad (17.10)$$

17.3 Regular Markov Chains

At the end of Section 17.2 (Markov Chains), we took the transition matrix T and started taking higher and higher powers of it. The matrix started to stabilize, and finally it reached its **steady-state** or **state of equilibrium**. When that happened, all the row vectors became the same, and we called one such row vector a **fixed probability vector** or an **equilibrium vector** E . Furthermore, we discovered that $ET = E$.

17.3.1 Section Overview

In this section, we wish to answer the following four questions.

1. Does every Markov chain reach a state of equilibrium?
2. Does the product of an equilibrium vector and its transition matrix always equal the equilibrium vector? That is, does $ET = E$?
3. Can the equilibrium vector E be found without raising the matrix to higher powers?
4. Does the long term market share distribution for a Markov chain depend on the initial market share?

Example 17.5

Does every Markov chain reach the state of equilibrium?

Solution

Answer: A Markov chain reaches a state of equilibrium if it is a **regular** Markov chain. A Markov chain is said to be a **regular Markov chain** if some power of it has only positive entries.

Example 17.6

Determine whether the following Markov chains are regular.

$$\begin{array}{l} \text{a. } A = \begin{bmatrix} 1 & 0 \\ .3 & .7 \end{bmatrix} \\ \text{b. } B = \begin{bmatrix} 0 & 1 \\ .4 & .6 \end{bmatrix} \end{array}$$

Solution

- a. The matrix A is not a regular Markov chain because every power of it has an entry 0 in the first row, second column position. In fact, we will show that all 2 by 2 matrices that have a zero in the first row, second column position are not regular. Consider the following matrix M .

$$M = \begin{bmatrix} a & 0 \\ b & c \end{bmatrix} \tag{17.11}$$

$$M^2 = \begin{bmatrix} a & 0 \\ b & c \end{bmatrix} \begin{bmatrix} a & 0 \\ b & c \end{bmatrix} = \begin{bmatrix} a \cdot a + 0 \cdot b & a \cdot 0 + 0 \cdot c \\ b \cdot a + c \cdot b & b \cdot 0 + c \cdot c \end{bmatrix} \tag{17.12}$$

Observe that the first row, second column entry, $a \cdot 0 + 0 \cdot c$, will always be zero, regardless of what power we raise the matrix to.

b. The transition matrix B is a regular Markov chain because

$$B^2 = \begin{bmatrix} .40 & .60 \\ .24 & .76 \end{bmatrix} \quad (17.13)$$

has only positive entries.

Example 17.7

Does the product of an equilibrium vector and its transition matrix always equal the equilibrium vector? That is, does $ET = E$?

Solution

At this point, the reader may have already guessed that the answer is yes if the transition matrix is a regular Markov chain. We try to illustrate with the following example from p. 277.

A small town is served by two telephone companies, Mama Bell and Papa Bell. Due to their aggressive sales tactics, each month 40% of Mama Bell customers switch to Papa Bell, that is, the other 60% stay with Mama Bell. On the other hand, 30% of the Papa Bell customers switch to Mama Bell. The transition matrix is given below.

		Next Month	
		Mama Bell	Papa Bell
First Month	Mama Bell	.60	.40
	Papa Bell	.30	.70

Figure 17.6

If the initial market share for Mama Bell is 20% and for Papa Bell 80%, we'd like to know the long term market share for each company.

Let matrix T denote the transition matrix for this Markov chain, and M denote the matrix that represents the initial market share. Then T and M are as follows:

$$T = \begin{bmatrix} .60 & .40 \\ .30 & .70 \end{bmatrix} \text{ and } M = \begin{bmatrix} .20 & .80 \end{bmatrix}$$

Since each month the towns people switch according to the transition matrix T , after one month the distribution for each company is as follows:

$$\begin{bmatrix} .20 & .80 \end{bmatrix} \begin{bmatrix} .60 & .40 \\ .30 & .70 \end{bmatrix} = \begin{bmatrix} .36 & .64 \end{bmatrix} \quad (17.14)$$

After two months, the market share for each company is

$$\begin{bmatrix} .36 & .64 \end{bmatrix} \begin{bmatrix} .60 & .40 \\ .30 & .70 \end{bmatrix} = \begin{bmatrix} .408 & .592 \end{bmatrix} \quad (17.15)$$

After three months the distribution is

$$\begin{bmatrix} .408 & .592 \end{bmatrix} \begin{bmatrix} .60 & .40 \\ .30 & .70 \end{bmatrix} = \begin{bmatrix} .4224 & .5776 \end{bmatrix} \quad (17.16)$$

After four months the market share is

$$\begin{bmatrix} .4224 & .5776 \end{bmatrix} \begin{bmatrix} .60 & .40 \\ .30 & .70 \end{bmatrix} = \begin{bmatrix} .42672 & .57328 \end{bmatrix} \quad (17.17)$$

After 30 months the market share is $\begin{bmatrix} 3/7 & 4/7 \end{bmatrix}$.

The market share after 30 months has stabilized to $\begin{bmatrix} 3/7 & 4/7 \end{bmatrix}$.

This means that

$$\begin{bmatrix} 3/7 & 4/7 \end{bmatrix} \begin{bmatrix} .60 & .40 \\ .30 & .70 \end{bmatrix} = \begin{bmatrix} 3/7 & 4/7 \end{bmatrix} \quad (17.18)$$

Once the market share reaches an equilibrium state, it stays the same, that is, $ET = E$.

This helps us answer the next question.

Example 17.8

Can the equilibrium vector E be found without raising the transition matrix to large powers?

Solution

The answer to the second question provides us with a way to find the equilibrium vector E .

The answer lies in the fact that $ET = E$.

Since we have the matrix T , we can determine E from the statement $ET = E$.

Suppose $E = \begin{bmatrix} e & 1 - e \end{bmatrix}$, then $ET = E$ gives us

$$\begin{bmatrix} e & 1 - e \end{bmatrix} \begin{bmatrix} .60 & .40 \\ .30 & .70 \end{bmatrix} = \begin{bmatrix} e & 1 - e \end{bmatrix} \quad (17.19)$$

$$\begin{bmatrix} (.60)e + .30(1 - e) & (.40)e + .70(1 - e) \end{bmatrix} = \begin{bmatrix} e & 1 - e \end{bmatrix} \quad (17.20)$$

$$\begin{bmatrix} .30e + .30 & -.30e + .70 \end{bmatrix} = \begin{bmatrix} e & 1 - e \end{bmatrix} \quad (17.21)$$

$$.30e + .30 = e \quad (17.22)$$

$$e = 3/7 \quad (17.23)$$

Therefore, $E = \begin{bmatrix} 3/7 & 4/7 \end{bmatrix}$

Example 17.9

Does the long term market share for a Markov chain depend on the initial market share?

Solution

We will show that the final market share distribution for a Markov chain does not depend upon the initial market share. In fact, one does not even need to know the initial market share distribution to find the long term distribution. Furthermore, the final market share distribution can be found by simply raising the transition matrix to higher powers.

Consider the initial market share $\begin{bmatrix} .20 & .80 \end{bmatrix}$, and the transition matrix $T = \begin{bmatrix} .60 & .40 \\ .30 & .70 \end{bmatrix}$ for Mama Bell and Papa Bell in the above example. Recall we found T^n , for very large n , to be $\begin{bmatrix} 3/7 & 4/7 \\ 3/7 & 4/7 \end{bmatrix}$.

$$\text{Clearly, } \begin{bmatrix} .20 & .80 \end{bmatrix} \begin{bmatrix} 3/7 & 4/7 \\ 3/7 & 4/7 \end{bmatrix} = \begin{bmatrix} 3/7 & 4/7 \end{bmatrix}$$

No matter what the initial market share, the product is $\begin{bmatrix} 3/7 & 4/7 \end{bmatrix}$.

If the initial share is $\begin{bmatrix} .10 & .90 \end{bmatrix}$, then

$$\begin{bmatrix} .10 & .90 \end{bmatrix} \begin{bmatrix} 3/7 & 4/7 \\ 3/7 & 4/7 \end{bmatrix} = \begin{bmatrix} 3/7 & 4/7 \end{bmatrix} \quad (17.24)$$

For any distribution $A = \begin{bmatrix} a & 1 - a \end{bmatrix}$, for example,

$$\begin{bmatrix} a & 1 - a \end{bmatrix} \begin{bmatrix} 3/7 & 4/7 \\ 3/7 & 4/7 \end{bmatrix} = \begin{bmatrix} 3/7(a) + 3/7(1 - a) & 4/7(a) + 4/7(1 - a) \end{bmatrix} = \begin{bmatrix} 3/7 & 4/7 \end{bmatrix} \quad (17.25)$$

It makes sense, because the entry $3/7(a) + 3/7(1 - a)$, for example, will always equal $3/7$.

Just as the sum of the parts equals the whole, the sum of the parts of $3/7$ equals $3/7$.

Example 17.10

Three companies, A , B , and C , compete against each other. The transition matrix T for people switching each month among them is given by the following transition matrix.

		Next Month		
		Company A	Company B	Company C
First Month	Company A	.1	.3	.6
	Company B	.6	.2	.2
	Company C	.1	.3	.6

Figure 17.7

If the initial market share for the companies A , B , and C is $\begin{bmatrix} .25 & .35 & .40 \end{bmatrix}$, what is the long term distribution?

Solution

Since the long term market share does not depend on the initial market share, we can simply raise the transition market share to a large power and get the distribution.

$$T^{20} = \begin{bmatrix} 13/55 & 3/11 & 27/55 \end{bmatrix} \quad (17.26)$$

We summarize as follows:

Regular Markov Chains

A Markov chain is said to be a Regular Markov chain if some power of it has only positive entries.

Let T be a transition matrix for a regular Markov chain.

1. As we take higher powers of T , T^n , as n becomes large, approaches a state of equilibrium.
2. If M is any distribution vector, and E an equilibrium vector, then $MT^n = E$.
3. Each row of the equilibrium matrix T^n is a unique equilibrium vector E such that $ET = E$.
4. The equilibrium distribution vector E can be found by letting $ET = E$.

17.4 Absorbing Markov Chains

In this section, we will study a type of Markov chain in which when a certain state is reached, it is impossible to leave that state. Such states are called **absorbing states**, and a Markov Chain that has at least one such state is called an **Absorbing Markov chain**. Suppose you have the following transition matrix.

$$\begin{array}{c} \begin{matrix} & S_1 & S_2 & S_3 \end{matrix} \\ \begin{matrix} S_1 \\ S_2 \\ S_3 \end{matrix} \begin{bmatrix} . & .3 & .6 \\ 0 & 1 & 0 \\ .3 & .2 & .5 \end{bmatrix} \end{array}$$

Figure 17.8

The state S_2 is an absorbing state, because the probability of moving from state S_2 to state S_2 is 1. Which is another way of saying that if you are in state S_2 , you will remain in state S_2 .

In fact, this is the way to identify an absorbing state. If the probability in row i and column i , p_{ii} , is 1, then state S_i is an absorbing state.

We begin with an application of absorbing Markov chains to the gambler's ruin problem.

Example 17.11: Gambler's Ruin Problem

A gambler has \$3,000, and she decides to gamble \$1,000 at a time at a Black Jack table in a casino in Las Vegas. She has told herself that she will continue playing until she goes broke or has \$5,000. Her probability of winning at Black Jack is .40. Write the transition matrix, identify the absorbing states, find the solution matrix, and determine the probability that the gambler will be financially ruined at a stage when she has \$2,000.

Solution

The transition matrix is written below. Clearly the state 0 and state 5K are the absorbing states. This makes sense because as soon as the gambler reaches 0, she is financially ruined and the game

is over. Similarly, if the gambler reaches \$5,000, she has promised herself to quit and, again, the game is over. The reader should note that $p_{00} = 1$, and $p_{55} = 1$.

Further observe that since the gambler bets only \$1,000 at a time, she can raise or lower her money only by \$1,000 at a time. In other words, if she has \$2,000 now, after the next bet she can have \$3,000 with a probability of .40 and \$1,000 with a probability of .60.

$$\begin{array}{r}
 \\
 0 \\
 1K \\
 2K \\
 3K \\
 4K \\
 5K
 \end{array}
 \begin{bmatrix}
 & 0 & 1K & 2K & 3K & 4K & 5K \\
 1 & 0 & 0 & 0 & 0 & 0 & 0 \\
 .60 & 0 & .40 & 0 & 0 & 0 & 0 \\
 0 & .60 & 0 & .40 & 0 & 0 & 0 \\
 0 & 0 & .60 & 0 & .40 & 0 & 0 \\
 0 & 0 & 0 & .60 & 0 & .40 & 0 \\
 0 & 0 & 0 & 0 & 0 & 0 & 1
 \end{bmatrix}$$

Figure 17.9

To determine the long term trend, we raise the matrix to higher powers until all the non-absorbing states are absorbed. This is called the **solution matrix**.

$$\begin{array}{r}
 \\
 0 \\
 1K \\
 2K \\
 3K \\
 4K \\
 5K
 \end{array}
 \begin{bmatrix}
 & 0 & 1K & 2K & 3K & 4K & 5K \\
 1 & 0 & 0 & 0 & 0 & 0 & 0 \\
 195/211 & 0 & 0 & 0 & 0 & 0 & 16/211 \\
 171/211 & 0 & 0 & 0 & 0 & 0 & 40/211 \\
 135/211 & 0 & 0 & 0 & 0 & 0 & 76/211 \\
 81/211 & 0 & 0 & 0 & 0 & 0 & 130/211 \\
 0 & 0 & 0 & 0 & 0 & 0 & 1
 \end{bmatrix}$$

Figure 17.10

The solution matrix is often written in the following form, where the non-absorbing states are written as rows on the side, and the absorbing states as columns on the top.

	0	5K
1K	195/211	16/211
2K	171/211	40/211
3K	135/211	76/211
4K	81/211	130/211

Figure 17.11

The table lists the probabilities of getting absorbed in state 0 or state 5K starting from any of the four non-absorbing states. For example, if at any instance the gambler has \$3,000, then her probability of financial ruin is 135/211.

Example 17.12

Solve the Gambler's Ruin Problem of Example 17.11 (Gambler's Ruin Problem) without raising the matrix to higher powers, and determine the number of bets the gambler makes before the game is over.

Solution

In solving absorbing states, it is often convenient to rearrange the matrix so that the rows and columns corresponding to the absorbing states are listed first. This is called the **Canonical form**. The transition matrix of Example 17.11 (Gambler's Ruin Problem) in the canonical form is listed below.

	0	5K	1K	2K	3K	4K
0	1	0	0	0	0	0
5K	0	1	0	0	0	0
1K	.60	0	0	.40	0	0
2K	0	0	.60	0	.40	0
3K	0	0	0	.60	0	.40
4K	0	.40	0	0	.60	0

Figure 17.12

The canonical form divides the transition matrix into four sub-matrices as listed below.

$$\begin{array}{l}
 \text{Absorbing states} \\
 \text{Non-absorbing states}
 \end{array}
 \left[\begin{array}{c|c}
 \text{Absorbing} & \text{Non-absorbing} \\
 \hline
 I_n & O \\
 \hline
 A & B
 \end{array} \right]$$

Figure 17.13

The matrix $F = (I_n - B)^{-1}$ is called the fundamental matrix for the absorbing Markov chain, where I_n is an identity matrix of the same size as B . The i, j -th entry of this matrix tells us the average number of times the process is in the non-absorbing state j before absorption if it started in the non-absorbing state i . The matrix F for our problem is listed below.

$$F = \begin{array}{l}
 1K \\
 2K \\
 3K \\
 4K
 \end{array}
 \left[\begin{array}{cccc}
 1K & 2K & 3K & 4K \\
 1.54 & .90 & .47 & .19 \\
 1.35 & 2.25 & 1.18 & .47 \\
 1.07 & 1.78 & 2.25 & .90 \\
 .64 & 1.07 & 1.35 & 1.54
 \end{array} \right]$$

Figure 17.14

The Fundamental matrix F helps us determine the average number of games played before absorption.

According to the matrix, the entry 1.78 in the row 3, column 2 position says that the gambler will play the game 1.78 times before she goes from \$3K to \$2K. The entry 2.25 in row 3, column 3 says that if the gambler now has \$3K, she will have \$3K on the average 2.25 times before the game is over.

We now address the question of how many bets will she have to make before she is absorbed, if the gambler begins with \$3K?

If we add the number of games the gambler plays in each non-absorbing state, we get the average number of games before absorption from that state. Therefore, if the gambler starts with \$3K, the average number of Black Jack games she will play before absorption is

$$1.07 + 1.78 + 2.25 + .90 = 6.0 \quad (17.27)$$

That is, we expect the gambler will either have \$5,000 or nothing on the 7th bet.

Lastly, we find the solution matrix without raising the transition matrix to higher powers.

The matrix FA gives us the solution matrix.

$$FA = \left[\begin{array}{cccc}
 1.54 & .90 & .47 & .19 \\
 1.35 & 2.25 & 1.18 & .47 \\
 1.07 & 1.78 & 2.25 & .90 \\
 .64 & 1.07 & 1.35 & 1.54
 \end{array} \right] \left[\begin{array}{cc}
 .6 & 0 \\
 0 & 0 \\
 0 & 0 \\
 0 & .4
 \end{array} \right] = \left[\begin{array}{cc}
 .92 & .08 \\
 .81 & .19 \\
 .64 & .36 \\
 .38 & .62
 \end{array} \right] \quad (17.28)$$

Which is the same as the following matrix we obtained by raising the transition matrix to higher powers.

	0	5K
1K	195/211	16/211
2K	171/211	40/211
3K	135/211	76/211
4K	81/211	130/211

Figure 17.15

We summarize as follows:

Absorbing Markov Chains

1. A Markov chain is an absorbing Markov chain if it has at least one absorbing state. A state i is an absorbing state if once the system reaches state i , it stays in that state; that is, $p_{ii} = 1$.
2. If a transition matrix T for an absorbing Markov chain is raised to higher powers, it reaches an absorbing state called the solution matrix and stays there. The i, j -th entry of this matrix gives the probability of absorption in state j while starting in state i .
3. Alternately, the solution matrix can be found in the following manner.
 - a. Express the transition matrix in the canonical form as below.

$$T = \begin{bmatrix} I_n & 0 \\ A & B \end{bmatrix} \quad (17.29)$$

where I_n is an identity matrix, and 0 is a matrix of all zeros.

- b. The fundamental matrix $F = (I - B)^{-1}$. The fundamental matrix helps us find the number of games played before absorption.
 - c. FA is the solution matrix, whose i, j -th entry gives the probability of absorption in state j while starting in state i .
4. The sum of the entries of a row of the fundamental matrix gives us the expected number of steps before absorption for the non-absorbing state associated with that row.

Chapter 18

Markov Chains: Homework¹

18.1 MARKOV CHAINS

Exercise 18.1

(Solution on p. 300.)

Is the matrix given below a transition matrix for a Markov chain? Explain.

a.
$$\begin{bmatrix} .2 & .3 & .5 \\ .3 & -.2 & .9 \\ .3 & .3 & .5 \end{bmatrix}$$

b.
$$\begin{bmatrix} .3 & .3 & .4 \\ .3 & .4 & .4 \\ 0 & 0 & 0 \end{bmatrix}$$

Exercise 18.2

A survey of American car buyers indicates that if a person buys a Ford, there is a 60% chance that their next purchase will be a Ford, while owners of a GM will buy a GM again with a probability of .80. The buying habits of these consumers are represented in the transition matrix below.

		Next Purchase	
		Ford	GM
Present Purchase	Ford	.60	.40
	GM	.20	.80

Figure 18.1

Find the following probabilities:

- The probability that a present owner of a Ford will buy a GM as his next car.
- The probability that a present owner of a GM will buy a GM as his next car.
- The probability that a present owner of a Ford will buy a GM as his third car.

¹This content is available online at <http://cnx.org/content/m38663/1.1/>.

- d. The probability that a present owner of a GM will buy a GM as his fourth car.

Exercise 18.3*(Solution on p. 300.)*

Professor Hay has breakfast at Hogue's every morning. He either orders an Egg Scramble, or a Tofu Scramble. He never orders Eggs on two consecutive days, but if he does order Tofu one day, then the next day he can order Tofu or Eggs with equal probability.

- Write a transition matrix for this problem.
- If Professor Hay has Tofu on the first day, what is the probability he will have Tofu on the second day?
- If Professor Hay has Eggs on the first day, what is the probability he will have Tofu on the third day?
- If Professor Hay has Eggs on the first day, what is the probability he will have Tofu on the fourth day?

Exercise 18.4

A professional tennis player always hits cross-court or down the line. In order to give himself a tactical edge, he never hits down the line two consecutive times, but if he hits cross-court on one shot, on the next shot he can hit cross-court with .75 probability and down the line with .25 probability.

- Write a transition matrix for this problem.
- If the player hit the first shot cross-court, what is the probability that he will hit the third shot down the line?

Exercise 18.5*(Solution on p. 300.)*

The transition matrix for switching political parties in an election year is given below, where Democrats, Republicans, and Independents are denoted by the letters D , R , and I , respectively.

		TO		
		D	R	I
FROM	D	.6	.3	.1
	R	.3	.6	.1
	I	.2	.2	.6

Figure 18.2

- Find the probability of a Democrat voting Republican.
- Find the probability of a Democrat voting Republican in the second election.
- Find the probability of a Republican voting Independent in the second election.
- Find the probability of a Democrat voting Independent in the third election.

18.2 REGULAR MARKOV CHAINS

Exercise 18.6

(Solution on p. 300.)

Determine whether the following matrices are regular Markov chains.

a.
$$\begin{bmatrix} 1 & 0 \\ .5 & .5 \end{bmatrix}$$

b.
$$\begin{bmatrix} .6 & .4 \\ 0 & 1 \end{bmatrix}$$

c.
$$\begin{bmatrix} .6 & 0 & .4 \\ .2 & .4 & .4 \\ 0 & 0 & 0 \end{bmatrix}$$

d.
$$\begin{bmatrix} .2 & .4 & .4 \\ .6 & .4 & 0 \\ .3 & .2 & .5 \end{bmatrix}$$

Exercise 18.7

Company I and Company II compete against each other, and the transition matrix for people switching from Company I to Company II is given below.

		TO	
		Company I	Company II
FROM	Company I	.3	.7
	Company II	.8	.2

Figure 18.3

Find the following.

- If the initial market share is 40% for Company I and 60% for Company II, what will the market share be after 3 steps?
- If this trend continues, what is the long range expectation for the market?

Exercise 18.8

(Solution on p. 300.)

Suppose the transition matrix for the tennis player in Exercise 18.4 is as follows, where C denotes the cross-court shots and D denotes down-the-line shots.

		Next Shot	
		C	D
Previous Shot	C	.9	.1
	D	.7	.3

Figure 18.4

Find the following.

- a. If the player hit the first shot cross-court, what is the probability he will hit the fourth shot cross-court?
- b. Determine the long term shot distribution.

Exercise 18.9

Professor Hay never orders eggs two days in a row, but if he orders tofu one day, then there is an equal probability that he will order tofu or eggs the next day.

Find the following:

- a. If Professor Hay had eggs on Monday, what is the probability that he will have tofu on Friday?
- b. Find the long term distribution for breakfast choices for Professor Hay.

Exercise 18.10

(Solution on p. 300.)

Many Russians have experienced a sharp decline in their living standards due to President Yeltsin's reforms. As a result, in the parliamentary elections held in December 1995, Communists and Nationalists made significant gains, and a new pattern in switching political parties emerged. The transition matrix for such a change is given below, where Communists, Nationalists, and Reformists are denoted by the letters C , N , and R , respectively.

		TO		
		C	N	R
FROM	C	.5	.4	.1
	N	.3	.4	.3
	R	.2	.2	.6

Figure 18.5

Find the following.

- a. If in this election Communists received 25% of the votes, Nationalists 30%, and Reformists the rest 45%, what will the distribution be in the next election?
- b. What will the distribution be in the third election?
- c. What will the distribution be in the fourth election?
- d. Determine the long term distribution.

18.3 ABSORBING MARKOV CHAINS

Exercise 18.11

(Solution on p. 300.)

Given the following absorbing Markov chain.

$$T = \begin{array}{c} \begin{array}{c} S1 \\ S2 \\ S3 \\ S4 \end{array} \left[\begin{array}{cccc} S1 & S2 & S3 & S4 \\ 1 & 0 & 0 & 0 \\ .1 & .4 & .2 & .3 \\ 0 & 0 & 1 & 0 \\ .4 & 0 & .2 & .4 \end{array} \right] \end{array}$$

Figure 18.6

Find the following:

- Identify the absorbing states.
- Write the solution matrix.
- Starting from state 4, what is the probability of eventual absorption in state 1?
- Starting from state 2, what is the probability of eventual absorption in state 3?

Exercise 18.12

Two tennis players, Andre and Vijay each with two dollars in their pocket, decide to bet each other \$1, for every game they play. They continue playing until one of them is broke.

Do the following:

- Write the transition matrix for Andre.
- Identify the absorbing states.
- Write the solution matrix.
- At a given stage if Andre has \$1, what is the chance that he will eventually lose it all?

Exercise 18.13

(Solution on p. 300.)

Repeat Exercise 18.12, if the chance of winning for Andre is .4 and for Vijay .6.

- Write the transition matrix for Andre.
- Write the solution matrix.
- If Andre has \$3, what is the probability that he will eventually be ruined?
- If Vijay has \$1, what is the probability that he will eventually triumph?

Exercise 18.14

Repeat Exercise 18.12, if initially Andre has \$3 and Vijay has \$2.

- Write the transition matrix.
- Identify the absorbing states.
- Write the solution matrix.
- If Andre has \$4, what is the probability that he will eventually be ruined?

Exercise 18.15*(Solution on p. 301.)*

The non-tenured professors at a community college are regularly evaluated. After an evaluation they are classified as good, bad, or improvable. The "improvable" are given a set of recommendations and are re-evaluated the following semester. At the next evaluation, 60% of the improvable turn out to be good, 20% bad, and 20% improvable. These percentages never change and the process continues.

- Write the transition matrix.
- Identify the absorbing states.
- Write the solution matrix.
- What is the probability that a professor who is improvable will eventually become good?

Exercise 18.16

A rat is placed in the maze shown below, and it moves from room to room randomly. From any room, the rat will choose a door to the next room with equal probabilities. Once it reaches room 1, it finds food and never leaves that room. And when it reaches room 5, it is trapped and cannot leave that room. What is the probability the rat will end up in room 5 if it was initially placed in room 3?

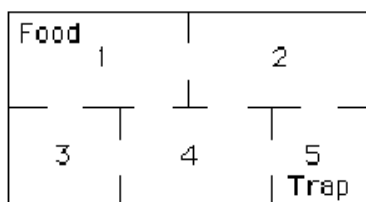

Figure 18.7

Exercise 18.17*(Solution on p. 302.)*

In Exercise 18.16, what is the probability the rat will end up in room 1 if it was initially placed in room 2?

18.4 CHAPTER REVIEW**Exercise 18.18***(Solution on p. 302.)*

Is the matrix given below a transition matrix for a Markov chain? Explain.

$$\text{a. } \begin{bmatrix} .1 & .4 & .5 \\ .5 & -.3 & .8 \\ .3 & .4 & .3 \end{bmatrix}$$

$$\text{b. } \begin{bmatrix} .2 & .6 & .2 \\ 0 & 0 & 0 \\ .3 & .4 & .5 \end{bmatrix}$$

Exercise 18.19*(Solution on p. 302.)*

A survey of computer buyers indicates that if a person buys an Apple computer, there is an 80% chance that their next purchase will be an Apple, while owners of an IBM will buy an IBM again with a probability of .70. The buying habits of these consumers are represented in the transition matrix below.

		Next Purchase	
		Apple	IBM
Present Purchase	Apple	.80	.20
	IBM	.30	.70

Figure 18.8

Find the following probabilities:

- The probability that a present owner of an Apple will buy an IBM as his next computer.
- The probability that a present owner of an Apple will buy an IBM as his third computer.
- The probability that a present owner of an IBM will buy an IBM as his fourth computer.

Exercise 18.20*(Solution on p. 302.)*

Professor Trayer either teaches Finite Math or Statistics each quarter. She never teaches Finite Math two consecutive quarters, but if she teaches Statistics one quarter, then the next quarter she will teach Statistics with a $1/3$ probability.

- Write a transition matrix for this problem.
- If Professor Trayer teaches Finite Math in the Fall quarter, what is the probability that she will teach Statistics in the Winter quarter.
- If Professor Trayer teaches Finite Math in the Fall quarter, what is the probability that she will teach Statistics in the Spring quarter.

Exercise 18.21*(Solution on p. 302.)*

The transition matrix for switching academic majors each quarter by students at a university is given below, where Science, Business, and Liberal Arts majors are denoted by the letters S , B , and A , respectively.

		TO		
		S	B	A
FROM	S	.6	.3	.1
	B	.1	.7	.2
	A	.1	.1	.8

Figure 18.9

- Find the probability of a science major switching to a business major during their first quarter.

- b. Find the probability of a business major switching to a Liberal Arts major during their second quarter.
- c. Find the probability of a science major switching to a Liberal Arts major during their third quarter.

Exercise 18.22*(Solution on p. 302.)*

Determine whether the following matrices are regular Markov chains.

a.
$$\begin{bmatrix} 1 & 0 \\ .3 & .7 \end{bmatrix}$$

b.
$$\begin{bmatrix} .2 & .4 & .4 \\ .6 & .4 & 0 \\ .3 & .2 & .5 \end{bmatrix}$$

Exercise 18.23*(Solution on p. 302.)*

John Elway, the football quarterback for the Denver Broncos, calls his own plays. At every play he has to decide to either pass the ball or hand it off. The transition matrix for his plays is given in the following table, where P represents a pass and H a handoff.

		Next Shot	
		P	H
Previous Shot	P	.6	.4
	H	.8	.2

Figure 18.10

Find the following.

- a. If John Elway threw a pass on the first play, what is the probability that he will handoff on the third play?
- b. Determine the long term play distribution.

Exercise 18.24*(Solution on p. 302.)*

Company I, Company II, and Company III compete against each other, and the transition matrix for people switching from company to company each year is given below.

		TO		
		I	II	III
FROM	I	.6	.2	.2
	II	.3	.5	.2
	III	.3	.3	.4

Figure 18.11

Find the following.

- If the initial market share is 20% for Company I, 30% for Company II and 50% for Company III, what will the market share be after the next year?
- If this trend continues, what is the long range expectation for the market?

Exercise 18.25*(Solution on p. 302.)*

Given the following absorbing Markov chain.

$$T = \begin{array}{c} \text{S1} \\ \text{S2} \\ \text{S3} \\ \text{S4} \end{array} \begin{bmatrix} \text{S1} & \text{S2} & \text{S3} & \text{S4} \\ 1 & 0 & 0 & 0 \\ 0 & 1 & 0 & 0 \\ .2 & .3 & .4 & .1 \\ .4 & .1 & .1 & .4 \end{bmatrix}$$

Figure 18.12

- Identify the absorbing states.
- Write the solution matrix.
- Starting from state 4, what is the probability of eventual absorption in state 1?
- Starting from state 3, what is the probability of eventual absorption in state 2?

Exercise 18.26*(Solution on p. 303.)*

A rat is placed in the maze shown below, and it moves from room to room randomly. From any room, the rat will choose a door to the next room with equal probabilities. Once it reaches room 1, it finds food and never leaves that room. And when it reaches room 6, it is trapped and cannot leave that room. What is the probability that the rat will end up in room 1 if it was initially placed in room 3?

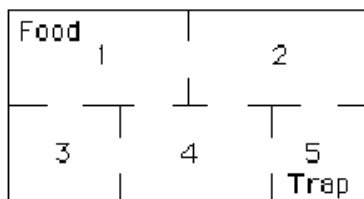
**Figure 18.13****Exercise 18.27***(Solution on p. 303.)*

In Exercise 18.26, what is the probability that the rat will end up in room 6 if it was initially in room 2?

Solutions to Exercises in Chapter 18

Solutions to Markov Chains: Homework

Solution to Exercise 18.1 (p. 291)

- a. No
- b. No

Solution to Exercise 18.3 (p. 292)

- a. $\begin{bmatrix} 0 & 1 \\ 1/2 & 1/2 \end{bmatrix}$
- b. $1/2$
- c. $1/2$
- d. $3/4$

Solution to Exercise 18.5 (p. 292)

- a. 0.3
- b. 0.38
- c. 0.15
- d. 0.175

Solution to Exercise 18.6 (p. 293)

- a. No c. No

Solution to Exercise 18.8 (p. 293)

- a. 0.876
- b. $\begin{bmatrix} 0.875 & 0.125 \end{bmatrix}$

Solution to Exercise 18.10 (p. 294)

- a. $\begin{bmatrix} .305 & .31 & 0.385 \end{bmatrix}$ c. $\begin{bmatrix} .32905 & .3291 & 0.3418 \end{bmatrix}$

Solution to Exercise 18.11 (p. 295)

- a. 1 and 3

$$2 \begin{bmatrix} 1 & 3 \\ 1/2 & 1/2 \\ 2/3 & 1/3 \end{bmatrix}$$

b.

Figure 18.14

- c. $2/3$
- d. $1/2$

Solution to Exercise 18.13 (p. 295)

a.

$$\begin{array}{c} 0 \\ 1 \\ 2 \\ 3 \\ 4 \end{array} \begin{bmatrix} 0 & 1 & 2 & 3 & 4 \\ 1 & 0 & 0 & 0 & 0 \\ .6 & 0 & .4 & 0 & 0 \\ 0 & .6 & 0 & .4 & 0 \\ 0 & 0 & .6 & 0 & .4 \\ 0 & 0 & 0 & 0 & 1 \end{bmatrix}$$

Figure 18.15

b. Andre's solution matrix

$$\begin{array}{c} 1 \\ 2 \\ 3 \end{array} \begin{bmatrix} 0 & 4 \\ 57/65 & 8/65 \\ 9/13 & 4/13 \\ 27/65 & 38/65 \end{bmatrix}$$

Figure 18.16

c. 27/65

d. 27/65

Solution to Exercise 18.15 (p. 296)

a.

$$\begin{array}{c} \mathbf{G} \\ \mathbf{B} \\ \mathbf{I} \end{array} \begin{bmatrix} \mathbf{G} & \mathbf{B} & \mathbf{I} \\ 1 & 0 & 0 \\ 0 & 1 & 0 \\ .60 & .20 & .20 \end{bmatrix}$$

Figure 18.17

b. I and II

- c. $\begin{bmatrix} 0.75 & 0.25 \end{bmatrix}$
 d. 0.75

Solution to Exercise 18.17 (p. 296)

10/19

(18.1)

Solution to Exercise 18.18 (p. 296)

- a. No
 b. No

Solution to Exercise 18.19 (p. 297)

- a. 0.2
 b. 0.3
 c. 0.475

Solution to Exercise 18.20 (p. 297)

- a. $\begin{bmatrix} 0 & 1 \\ 2/3 & 1/3 \end{bmatrix}$
 b. 1
 c. $2/3$

Solution to Exercise 18.21 (p. 297)

- a. 0.3
 b. 0.31
 c. 0.28

Solution to Exercise 18.22 (p. 298)

- a. No
 b. Yes

Solution to Exercise 18.23 (p. 298)

- a. 0.32
 b. $P = 2/3, H = 1/3$

Solution to Exercise 18.24 (p. 298)

- a. $\begin{bmatrix} .36 & .34 & .30 \end{bmatrix}$
 b. $\begin{bmatrix} 3/7 & 9/28 & 1/4 \end{bmatrix}$

Solution to Exercise 18.25 (p. 299)

- a. S1 and S2

b.

$$\begin{array}{c} \text{S3} \\ \text{S4} \end{array} \begin{bmatrix} \text{S1} & \text{S2} \\ 16/35 & 19/35 \\ 26/35 & 9/35 \end{bmatrix}$$

Figure 18.18

c. $26/35$

d. $19/35$

Solution to Exercise 18.26 (p. 299)

$2/7$

(18.2)

Solution to Exercise 18.27 (p. 299)

$3/7$

Chapter 19

Game Theory¹

19.1 Chapter Overview

In this chapter, you will learn to:

1. Solve strictly determined games.
2. Solve games involving mixed strategies.

19.2 Strictly Determined Games

Game theory is one of the newest branches of mathematics. It first came to light when a brilliant mathematician named Dr. John von Neumann co-authored with Dr. Morgenstern a book titled *Theory of Games and Economic Behavior*. Since then it has played an important role in decision making in business, economics, social sciences and other fields.

In this chapter, we will study games that involve only two players. In these games, since a win for one person is a loss for the other, we refer to them as **two-person zero-sum games**. Although the games we will study here are fairly simple, they will provide us with an understanding of how games work and how they are applied in practical situations. We begin with an example.

Example 19.1

Robert and Carol decide to play a game using a dime and a quarter. Each chooses one of the two coins, puts it in their hand and closes their fist. At a given signal, they simultaneously open their fists. If the sum of the coins is less than thirty five cents, Robert gets both coins, otherwise, Carol gets both coins. Write the matrix for the game, determine the optimal strategies for each player, and find the expected payoff for Robert.

Solution

Suppose Robert is the row player, that is, he plays the rows, and Carol is a column player. If Robert shows a dime and Carol shows a dime, the sum will be less than thirty five cents and Robert will win ten cents. But, if Robert shows a dime and Carol shows a quarter, the sum will not be less than thirty five cents and Carol will win ten cents or Robert will lose ten cents. The following matrix depicts all four cases and their corresponding payoffs for Robert. Remember a negative value is a loss for Robert and a win for Carol.

¹This content is available online at <<http://cnx.org/content/m18910/1.2/>>.

		Carol	
		Dime	Quarter
Robert	Dime	10	-10
	Quarter	-25	-25

Figure 19.1

The best strategy for Robert is to always show a dime because this way the worst he can do is lose ten cents. And, the best strategy for Carol is to always show a quarter because that way the worst she can do is to lose ten cents. If both Robert and Carol play their optimal strategies, Robert will lose ten cents each time. Therefore, the value of the game is negative ten cents.

In Example 19.1, since there is only one fixed optimal strategy for each player, regardless of their opponent's strategy, we say the game possesses a **pure strategy** and is **strictly determined**.

Next, we formulate a method to find the optimal strategy for each player and the value of the game. The method involves considering the worst scenario for each player.

To consider the worst situation, the row player considers the minimum value in each row, and the column player considers the maximum value in each column. Note that the maximum value really represents a minimum value for the column player because the game matrix depicts the payoffs for the row player. We list the method below.

Finding the Optimal Strategy and the Value for Strictly Determined Games

1. Put an asterisk(*) next to the minimum entry in each row.
2. Put a box around the maximum entry in each column.
3. The entry that has both an asterisk and a box represents the value of the game and is called a **saddle point**.
4. The row that is associated with the saddle point represents the best strategy for the row player, and the column that is associated with the saddle point represents the best strategy for the column player.
5. A game matrix can have more than one saddle point, but all saddle points have the same value.
6. If no saddle point exists, the game is not strictly determined. Non-strictly determined games are the subject of Section 19.3 (Non-Strictly Determined Games).

Example 19.2

Find the saddle points and optimal strategies for the following game.

		Column Player	
		-25	10
Row Player	10	-25	10
	50	10	50

Figure 19.2

Solution

We find the saddle point by placing an asterisk next to the minimum entry in each row, and by putting a box around the maximum entry in each column as shown below.

		Column Player	
		Dime	Quarter
Row Player	Dime	-25*	10
	Quarter	10*	50

Figure 19.3

Since the second row, first column entry, which happens to be 10, has both an asterisk and a box, it is a saddle point. This implies that the value of the game is 10, and the optimal strategy for the row player is to always play row 2, and the optimal strategy for the column player is to always play column 1. If both players play their optimal strategies, the row player will win 10 units each time.

The row player's strategy is written as $\begin{bmatrix} 0 & 1 \end{bmatrix}$ indicating that he will play row 1 with a probability of 0 and row 2 with a probability of 1. Similarly the column player's strategy is written as $\begin{bmatrix} 1 \\ 0 \end{bmatrix}$ implying that he will play column 1 with a probability of 1, and column 2 with a probability of 0.

19.3 Non-Strictly Determined Games

In this section, we study games that have no saddle points. Which means that these games do not possess a pure strategy. We call these games **non-strictly determined games**. If the game is played only once, it will make no difference what move is made. However, if the game is played repeatedly, a **mixed strategy** consisting of alternating random moves can be worked out.

We consider the following example.

Example 19.3

Suppose Robert and Carol decide to play a game using a dime and a quarter. At a given signal, they simultaneously show one of the two coins. If the coins match, Robert gets both coins, but if they don't match, Carol gets both coins. Determine whether the game is strictly determined.

Solution

We write the payoff matrix for Robert as follows:

		Carol	
		Dime	Quarter
Robert	Dime	10	-10
	Quarter	-25	25

Figure 19.4

To determine whether the game is strictly determined, we look for a saddle point. Again, we place an asterisk next to the minimum value in each row, and a box around the maximum value in each column. We get

		Carol	
		Dime	Quarter
Robert	Dime	10	-10*
	Quarter	-25*	25

Figure 19.5

Since there is no entry that has both an asterisk and a box, the game does not have a saddle point, and thus it is non-strictly determined.

We wish to devise a strategy for Robert. If Robert consistently shows a dime, for example, Carol will see the pattern and will start showing a quarter, and Robert will lose. Conversely, if Carol repeatedly shows a quarter, Robert will start showing a quarter, thus resulting in Carol's loss. So a good strategy is to throw your opponent off by showing a dime some of the times and showing a quarter other times. Before we develop an optimal strategy for each player, we will consider an arbitrary strategy for each and determine the corresponding payoffs.

Example 19.4

Suppose in Example 19.3, Robert decides to show a dime with .20 probability and a quarter with .80 probability, and Carol decides to show a dime with .70 probability and a quarter with .30 probability. What is the expected payoff for Robert?

Solution

Let R denote Robert's strategy and C denote Carol's strategy.

Since Robert is a row player and Carol is a column player, their strategies are written as follows:

$$R = \begin{bmatrix} .20 & .80 \end{bmatrix} \text{ and } C = \begin{bmatrix} .70 \\ .30 \end{bmatrix}.$$

To find the expected payoff, we use the following reasoning.

Since Robert chooses to play row 1 with .20 probability and Carol chooses to play column 1 with .70 probability, the move row 1, column 1 will be chosen with $(.20)(.70) = .14$ probability. The fact that this move has a payoff of 10 cents for Robert, Robert's expected payoff for this move is $(.14)(10) = .14$ cents. Similarly, we compute Robert's expected payoffs for the other cases. The table below lists expected payoffs for all four cases.

Move	Probability	Payoff	Expected Payoff
Row 1, Column 1	$(.20)(.70) = .14$	10 cents	1.4 cents
Row 1, Column 2	$(.20)(.30) = .06$	-10 cents	-.6 cents
Row 2, Column 1	$(.80)(.70) = .56$	-25 cents	-14 cents
Row 2, Column 2	$(.80)(.30) = .24$	25 cents	6.0 cents
Totals	1		-7.2 cents

Table 19.1

The above table shows that if Robert plays the game with the strategy $R = \begin{bmatrix} .20 & .80 \end{bmatrix}$ and Carol plays with the strategy $C = \begin{bmatrix} .70 \\ .30 \end{bmatrix}$, Robert can expect to lose 7.2 cents for every game.

Alternatively, if we call the game matrix G , then the expected payoff for the row player can be determined by multiplying matrices R , G and C . Thus, the expected payoff P for Robert is as follows:

$$\begin{aligned} P &= RCG \\ P &= \begin{bmatrix} .20 & .80 \end{bmatrix} \begin{bmatrix} 10 & -10 \\ -25 & 25 \end{bmatrix} \begin{bmatrix} .70 \\ .30 \end{bmatrix} \\ &= -7.2 \text{ cents} \end{aligned} \tag{19.1}$$

Which is the same as the one obtained from the table.

Example 19.5

For the following game matrix G , determine the optimal strategy for both the row player and the column player, and find the value of the game.

$$G = \begin{bmatrix} 1 & -2 \\ -3 & 4 \end{bmatrix} \tag{19.2}$$

Solution

Let us suppose that the row player uses the strategy $R = \begin{bmatrix} r & 1 - r \end{bmatrix}$. Now if the column player plays column 1, the expected payoff P for the row player is

$$P(r) = 1(r) + (-3)(1 - r) = 4r - 3.$$

Which can also be computed as follows:

$$P(r) = \begin{bmatrix} r & 1 - r \end{bmatrix} \begin{bmatrix} 1 \\ -3 \end{bmatrix} \text{ or } 4r - 3.$$

If the row player plays the strategy $\begin{bmatrix} r & 1 - r \end{bmatrix}$ and the column player plays column 2, the expected payoff P for the row player is

$$P(r) = \begin{bmatrix} r & 1 - r \end{bmatrix} \begin{bmatrix} -2 \\ 4 \end{bmatrix} = -6r + 4.$$

We have two equations

$$P(r) = 4r - 3 \text{ and } P(r) = -6r + 4$$

The row player is trying to improve upon his worst scenario, and that only happens when the two lines intersect. Any point other than the point of intersection will not result in optimal strategy as one of the expectations will fall short.

Solving for r algebraically, we get

$$4r - 3 = -6r + 4 \tag{19.3}$$

$$r = 7/10.$$

Therefore, the optimal strategy for the row player is $\begin{bmatrix} .7 & .3 \end{bmatrix}$.

Alternatively, we can find the optimal strategy for the row player by, first, multiplying the row matrix with the game matrix as shown below.

$$\begin{bmatrix} r & 1-r \end{bmatrix} \begin{bmatrix} 1 & -2 \\ -3 & 4 \end{bmatrix} = \begin{bmatrix} 4r-3 & -6r+4 \end{bmatrix} \quad (19.4)$$

And then by equating the two entries in the product matrix. Again, we get $r = .7$, which gives us the optimal strategy $\begin{bmatrix} .7 & .3 \end{bmatrix}$.

We use the same technique to find the optimal strategy for the column player.

Suppose the column player's optimal strategy is represented by $\begin{bmatrix} c \\ 1-c \end{bmatrix}$. We, first, multiply the game matrix by the column matrix as shown below.

$$\begin{bmatrix} 1 & -2 \\ -3 & 4 \end{bmatrix} \begin{bmatrix} c \\ 1-c \end{bmatrix} = \begin{bmatrix} 3c-2 \\ -7c+4 \end{bmatrix} \quad (19.5)$$

And then equate the entries in the product matrix. We get

$$3c-2 = -7c+4 \quad (19.6)$$

$$c = .6 \quad (19.7)$$

Therefore, the column player's optimal strategy is $\begin{bmatrix} .6 \\ .4 \end{bmatrix}$.

To find the expected value, V , of the game, we find the product of the matrices R , G and C .

$$V = \begin{bmatrix} .7 & .3 \end{bmatrix} \begin{bmatrix} 1 & -2 \\ -3 & 4 \end{bmatrix} \begin{bmatrix} .6 \\ .4 \end{bmatrix} = \begin{bmatrix} .6 \\ -.2 \end{bmatrix} \quad (19.8)$$

That is, if both players play their optimal strategies, the row player can expect to lose .2 units for every game.

Example 19.6

For the game in Example 19.3, determine the optimal strategy for both Robert and Carol, and find the value of the game.

Solution

Since we have already determined that the game is non-strictly determined, we proceed to determine the optimal strategy for the game. We rewrite the game matrix.

$$G = \begin{bmatrix} 10 & -10 \\ -25 & 25 \end{bmatrix} \quad (19.9)$$

Let $R = \begin{bmatrix} r & 1-r \end{bmatrix}$ be Robert's strategy, and $C = \begin{bmatrix} c \\ 1-c \end{bmatrix}$ be Carol's strategy.

To find the optimal strategy for Robert, we, first, find the product RG as below.

$$\begin{bmatrix} r & 1-r \end{bmatrix} \begin{bmatrix} 10 & -10 \\ -25 & 25 \end{bmatrix} = \begin{bmatrix} 35r-25 & -35r+25 \end{bmatrix} \quad (19.10)$$

By setting the entries equal, we get

$$35r - 25 = -35r + 25$$

or $r = 5/7$.

Therefore, the optimal strategy for Robert is $\begin{bmatrix} 5/7 & 2/7 \end{bmatrix}$.

To find the optimal strategy for Carol, we, first, find the following product.

$$\begin{bmatrix} 10 & -10 \\ -25 & 25 \end{bmatrix} \begin{bmatrix} c \\ 1-c \end{bmatrix} = \begin{bmatrix} 20c-10 \\ -50c+25 \end{bmatrix} \quad (19.11)$$

We now set the entries equal to each other, and we get,

$$20c - 10 = -50c + 25 \quad (19.12)$$

or $c = 1/2$

Therefore, the optimal strategy for Carol is $\begin{bmatrix} 1/2 \\ 1/2 \end{bmatrix}$.

To find the expected value, V , of the game, we find the product $RG C$.

$$\begin{aligned} V &= \begin{bmatrix} 5/7 & 2/7 \end{bmatrix} \begin{bmatrix} 10 & -10 \\ -25 & 25 \end{bmatrix} \begin{bmatrix} 1/2 \\ 1/2 \end{bmatrix} \\ &= [0] \end{aligned} \quad (19.13)$$

If both players play their optimal strategy, the value of the game is zero. In such case, the game is called **fair**.

19.4 Reduction by Dominance

Sometimes an $m \times n$ game matrix can be reduced to a 2×2 matrix by deleting certain rows and columns. A row can be deleted if there exists another row that will produce a payoff of an equal or better value. Similarly, a column can be deleted if there is another column that will produce a payoff of an equal or better value for the column player. The row or column that produces a better payoff for its corresponding player is said to **dominate** the row or column with the lesser payoff.

Example 19.7

For the following game, determine the optimal strategy for both the row player and the column player, and find the value of the game.

$$G = \begin{bmatrix} -2 & 6 & 4 \\ -1 & -2 & -3 \\ 1 & 2 & -2 \end{bmatrix} \quad (19.14)$$

Solution

We first look for a saddle point and determine that none exist. Next, we try to reduce the matrix to a 2×2 matrix by eliminating the dominated row.

Since every entry in row 3 is larger than the corresponding entry in row 2, row 3 dominates row 2. Therefore, a rational row player will never play row 2, and we eliminate row 2. We get

$$\begin{bmatrix} -2 & 6 & 4 \\ 1 & 2 & -2 \end{bmatrix} \quad (19.15)$$

Now we try to eliminate a column. Remember that the game matrix represents the payoffs for the row player and not the column player; therefore, the larger the number in the column, the smaller the payoff for the column player.

The column player will never play column 2, because it is dominated by both column 1 and column 3. Therefore, we eliminate column 2 and get the modified matrix, M , below.

$$M = \begin{bmatrix} -2 & 4 \\ 1 & -2 \end{bmatrix} \quad (19.16)$$

To find the optimal strategy for both the row player and the column player, we use the method learned in the Section 19.2 (Strictly Determined Games).

Let the row player's strategy be $R = \begin{bmatrix} r & 1-r \end{bmatrix}$, and the column player's strategy be $C = \begin{bmatrix} c \\ 1-c \end{bmatrix}$.

To find the optimal strategy for the row player, we, first, find the product RM as below.

$$\begin{bmatrix} r & 1-r \end{bmatrix} \begin{bmatrix} -2 & 4 \\ 1 & -2 \end{bmatrix} = \begin{bmatrix} -3r+1 & 6r-2 \end{bmatrix} \quad (19.17)$$

By setting the entries equal, we get

$$-3r+1 = 6r-2 \quad (19.18)$$

or $r = 1/3$.

Therefore, the optimal strategy for the row player is $\begin{bmatrix} 1/3 & 2/3 \end{bmatrix}$, but relative to the original game matrix it is $\begin{bmatrix} 1/3 & 0 & 2/3 \end{bmatrix}$.

To find the optimal strategy for the column player we, first, find the following product.

$$\begin{bmatrix} -2 & 4 \\ 1 & -2 \end{bmatrix} \begin{bmatrix} c \\ 1-c \end{bmatrix} = \begin{bmatrix} -6c+4 \\ 3c-2 \end{bmatrix} \quad (19.19)$$

We set the entries in the product matrix equal to each other, and we get,

$$-6c+4 = 3c-2 \quad (19.20)$$

or $c = 2/3$

Therefore, the optimal strategy for the column player is $\begin{bmatrix} 2/3 \\ 1/3 \end{bmatrix}$, but relative to the original game matrix, the strategy for the column player is $\begin{bmatrix} 2/3 \\ 0 \\ 1/3 \end{bmatrix}$.

To find the expected value, V , of the game, we have two choices: either to find the product of matrices R , M and C , or multiply the optimal strategies relative to the original matrix to the original matrix. We choose the first, and get

$$\begin{aligned} V &= \begin{bmatrix} 1/3 & 2/3 \end{bmatrix} \begin{bmatrix} -2 & 4 \\ 1 & -2 \end{bmatrix} \begin{bmatrix} 2/3 \\ 1/3 \end{bmatrix} \\ &= [0] \end{aligned} \tag{19.21}$$

Therefore, if both players play their optimal strategy, the value of the game is zero.

We summarize as follows:

Reduction by Dominance

1. Sometimes an $m \times n$ game matrix can be reduced to a 2×2 matrix by deleting **dominated** rows and columns.
2. A row is called a **dominated row** if there exists another row that will produce a payoff of an equal or better value. That happens when there exists a row whose every entry is larger than the corresponding entry of the dominated row.
3. A column is called a **dominated column** if there exists another column that will produce a payoff of an equal or better value. This happens when there exists a column whose every entry is smaller than the corresponding entry of the dominated row.

Chapter 20

Game Theory: Homework¹

20.1 STRICTLY DETERMINED GAMES

Exercise 20.1

(Solution on p. 323.)

Determine whether the games are strictly determined. If the games are strictly determined, find the optimal strategies for each player and the value of the game.

a. $\begin{bmatrix} 1 & 2 \\ -2 & 3 \end{bmatrix}$

b. $\begin{bmatrix} 6 & 3 \\ 2 & 1 \end{bmatrix}$

c. $\begin{bmatrix} -1 & -3 & 2 \\ 0 & 3 & -1 \\ 1 & -2 & 4 \end{bmatrix}$

d. $\begin{bmatrix} 2 & 0 & -4 \\ 3 & 4 & 2 \\ 0 & -2 & -3 \end{bmatrix}$

e. $\begin{bmatrix} 0 & 2 \\ -1 & -1 \\ -1 & 1 \\ 3 & 2 \end{bmatrix}$

f. $\begin{bmatrix} 5 & -3 & 2 \\ 3 & -1 & 4 \end{bmatrix}$

Exercise 20.2

Two players play a game which involves holding out one or two fingers simultaneously. If the sum of the fingers is more than 2, Player II pays Player I the sum of the fingers; otherwise, Player I pays Player II the sum of the fingers.

¹This content is available online at <<http://cnx.org/content/m38665/1.1/>>.

- Write a payoff matrix for Player I.
- Find the optimal strategies for each player and the value of the game.

Exercise 20.3*(Solution on p. 323.)*

A mayor of a large city is thinking of running for re-election, but does not know who his opponent is going to be. It is now time for him to take a stand for or against abortion. If he comes out against abortion rights and his opponent is for abortion, he will increase his chances of winning by 10%. But if he is against abortion and so is his opponent, he gains only 5%. On the other hand, if he is for abortion and his opponent against, he decreases his chance by 8%, and if he is for abortion and so is his opponent, he decreases his chance by 12%.

- Write a payoff matrix for the mayor.
- Find the optimal strategies for the mayor and his opponent.

Exercise 20.4

A man accused of a crime is not sure whether anybody saw him do it. He needs to make a choice of pleading innocent or pleading guilty to a lesser charge. If he pleads innocent and nobody comes forth, he goes free. However, if a witness comes forth, the man will be sentenced to 10 years in prison. On the other hand, if he pleads guilty to a lesser charge and nobody comes forth, he gets a sentence of one year and if a witness comes forth, he gets a sentence of 3 years.

- Write a payoff matrix for the accused.
- If you were his attorney, what strategy would you advise?

20.2 NON-STRICTLY DETERMINED GAMES**Exercise 20.5***(Solution on p. 323.)*

Determine the optimal strategies for both the row player and the column player, and find the value of the game.

- $\begin{bmatrix} -1 & 1 \\ 1 & -1 \end{bmatrix}$
- $\begin{bmatrix} 1 & -1 \\ -4 & 0 \end{bmatrix}$
- $\begin{bmatrix} 3 & -2 \\ 2 & 4 \end{bmatrix}$
- $\begin{bmatrix} -3 & 2 \\ 1 & -4 \end{bmatrix}$

Exercise 20.6

Find the expected payoff for the given game matrix G if the row player plays strategy R , and column player plays strategy C .

$$\text{a. } G = \begin{bmatrix} -3 & 2 \\ 1 & -4 \end{bmatrix} \quad R = \begin{bmatrix} 2/3 & 1/3 \end{bmatrix} \quad C = \begin{bmatrix} 1/4 \\ 3/4 \end{bmatrix}$$

$$\text{b. } G = \begin{bmatrix} -1 & 1 \\ 1 & -1 \end{bmatrix} \quad R = \begin{bmatrix} 1/3 & 2/3 \end{bmatrix} \quad C = \begin{bmatrix} 2/3 \\ 1/3 \end{bmatrix}$$

Exercise 20.7*(Solution on p. 323.)*

Two players play a game which involves holding out one or two fingers simultaneously. If the sum of the fingers is even, Player II pays Player I the sum of the fingers. If the sum of the fingers is odd, Player I pays Player II the sum of the fingers.

- Write a payoff matrix for Player I.
- Find the optimal strategies for both the row player and the column player, and the value of the game.

Exercise 20.8

In December 1995, President Clinton ordered the first of 20,000 U. S. troops to be sent into Bosnia-Herzegovina as a peace keeping force. Unfortunately, the heavy fog made visibility very poor at the Tuzla airfield, and at the same time increased the threat of sniper attacks from the Serbian forces. U. S. Air Force Col. Neal Patton, and Lt. Col. Sid Kooyman, the advance specialists, had two choices: either to send in the troops by air with the difficulties already described or by road thus exposing the troops to ambush by the Serbian forces. The Serbian army, with its limited resources, had a choice of deploying its forces near the airport or along the road route.

If the U. S. lands its troops on the airfield in the fog while the Serbs are concentrating on the road route, the payoff for U. S. is 20 points. But if the U. S. lands its troops on the airfield, and Serbians are there hiding in the fog, U. S. wins only 5 points. On the other hand, if U. S. transports its troops by road and avoids Serbs its payoff is 35 points, but if U. S. meets Serb resistance on the road route, it loses 50 points.

- Write a payoff matrix for the game.
- If you were Air Force Col. Neal Patton's advisor, what advice would you give him?

20.3 REDUCTION BY DOMINANCE

Reduce the payoff matrix by dominance. Find the optimal strategy for each player and the value of the game.

Exercise 20.9*(Solution on p. 324.)*

$$\begin{bmatrix} 2 & -1 \\ 0 & 3 \\ -2 & 0 \end{bmatrix} \quad (20.1)$$

Exercise 20.10

$$\begin{bmatrix} 2 & 3 \\ 4 & 5 \\ 5 & 4 \end{bmatrix} \quad (20.2)$$

Exercise 20.11*(Solution on p. 324.)*

$$\begin{bmatrix} 1 & 3 & -2 \\ -2 & 9 & 4 \\ -5 & 0 & 1 \end{bmatrix} \quad (20.3)$$

Exercise 20.12

$$\begin{bmatrix} 0 & 1 & 1 \\ 0 & 1 & 2 \\ 1 & 2 & 4 \\ 3 & 1 & 3 \end{bmatrix} \quad (20.4)$$

Exercise 20.13*(Solution on p. 324.)*

$$\begin{bmatrix} 2 & 0 & -4 & 8 \\ 0 & -6 & -6 & 2 \\ 2 & -2 & 4 & 6 \\ -2 & -4 & -8 & 0 \end{bmatrix} \quad (20.5)$$

Exercise 20.14

$$\begin{bmatrix} -1 & 3 & 2 & 4 \\ 1 & 2 & 0 & 5 \end{bmatrix} \quad (20.6)$$

Exercise 20.15*(Solution on p. 324.)*

$$\begin{bmatrix} -5 & -1 & -1 & 3 \\ -10 & 1 & 2 & -8 \\ 4 & 0 & 1 & 5 \\ 3 & -8 & 0 & 5 \end{bmatrix} \quad (20.7)$$

Exercise 20.16

$$\begin{bmatrix} 1 & -3 & -4 & 1 \\ 1 & -4 & -1 & 3 \\ 1 & 1 & -1 & 1 \\ 0 & -1 & 1 & 1 \end{bmatrix} \quad (20.8)$$

20.4 CHAPTER REVIEW

Exercise 20.17

(Solution on p. 324.)

Determine whether the games are strictly determined. If the games are strictly determined, find the optimal strategies for each player and the value of the game.

a.
$$\begin{bmatrix} 2 & 3 \\ 3 & 4 \end{bmatrix}$$

b.
$$\begin{bmatrix} 0 & 3 & -1 \\ 1 & 3 & -2 \\ -1 & 2 & -5 \end{bmatrix}$$

c.
$$\begin{bmatrix} 3 & 2 & -1 \\ 5 & 3 & 4 \end{bmatrix}$$

d.
$$\begin{bmatrix} 4 & 2 \\ -1 & 3 \\ 4 & 3 \\ 1 & -3 \end{bmatrix}$$

Exercise 20.18

(Solution on p. 324.)

Two players play a game which involves holding out a nickel or a dime simultaneously. If the sum of the coins is more than 10 cents, Player I gets both the coins; otherwise, Player II gets both the coins.

- Write a payoff matrix for Player I.
- Find the optimal strategies for each player and the value of the game.

Exercise 20.19

(Solution on p. 325.)

Lacy's department store is thinking of having a major sale in the month of February, but does not know if its competitor store Hordstrom's is also planning one. If Lacy's has a sale and Hordstrom's does not, Lacy's sales go up by 30%, but if both stores have a sale simultaneously, Lacy's sales go up by only 5%. On the other hand, if Lacy's does not have a sale and Hordstrom's does, Lacy's loses 5% of its sales to Hordstrom's, and if neither of the stores has a sale, Lacy's experiences no gain in sales.

- Write a payoff matrix for Lacy's.
- Find the optimal strategies for both stores.

Exercise 20.20

(Solution on p. 325.)

Mr. Halsey has a choice of three investments: Investment A, Investment B, and Investment C. If the economy booms, then Investment A yields 14% return, Investment B returns 8%, and Investment C 11%. If the economy grows moderately, then Investment A yields 12% return, Investment B returns 11%, and Investment C 11%. If the economy experiences a recession, then Investment A yields a 6% return, Investment B returns 9%, and Investment C 10%.

- Write a payoff matrix for Mr. Halsey.
- What would you advise him?

Exercise 20.21*(Solution on p. 325.)*

Mr. Thaggert is trying to decide whether to invest in stocks or in CD's (Certificate of deposit). If he invests in stocks and the interest rates go up, his stock investments go down by 2%, but he gains 1% in his CD's. On the other hand if the interest rates go down, he gains 3% in his stock investments, but he loses 1% in his CD's.

- Write a payoff matrix for Mr. Thaggert.
- If you were his investment advisor, what strategy would you advise?

Exercise 20.22*(Solution on p. 325.)*

Determine the optimal strategies for both the row player and the column player, and find the value of the game.

$$\begin{array}{l} \text{a.} \begin{bmatrix} 2 & -2 \\ -2 & 2 \end{bmatrix} \\ \text{b.} \begin{bmatrix} -2 & 2 \\ 5 & 0 \end{bmatrix} \\ \text{c.} \begin{bmatrix} 3 & 5 \\ 4 & -1 \end{bmatrix} \\ \text{d.} \begin{bmatrix} -2 & 5 \\ 4 & -3 \end{bmatrix} \end{array}$$

Exercise 20.23*(Solution on p. 325.)*

Find the expected payoff for the given game matrix G if the row player plays strategy R , and the column player plays strategy C .

$$\begin{array}{l} \text{a. } G = \begin{bmatrix} 3 & 5 \\ 4 & -1 \end{bmatrix} R = \begin{bmatrix} 1/2 & 1/2 \end{bmatrix} C = \begin{bmatrix} 1/4 \\ 3/4 \end{bmatrix} \\ \text{b. } G = \begin{bmatrix} -2 & 5 \\ 4 & -3 \end{bmatrix} R = \begin{bmatrix} 2/3 & 1/3 \end{bmatrix} C = \begin{bmatrix} 1/3 \\ 2/3 \end{bmatrix} \end{array}$$

Exercise 20.24*(Solution on p. 325.)*

A group of thieves are planning to burglarize either Warehouse A or Warehouse B. The owner of the warehouses has the manpower to secure only one of them. If Warehouse A is burglarized the owner will lose \$20,000, and if Warehouse B is burglarized the owner will lose \$30,000. There is a 40% chance that the thieves will burglarize Warehouse A and 60% chance they will burglarize Warehouse B. There is a 30% chance that the owner will secure Warehouse A and 70% chance he will secure Warehouse B. What is the owner's expected loss?

Exercise 20.25*(Solution on p. 325.)*

Two players play a game which involves holding out a nickel or a dime. If the sum of the coins is odd, Player I gets both the coins, and if the sum of the coins is even, Player II gets both the coins. Determine the optimal strategies for both the row player and the column player, and find the expected payoff.

Exercise 20.26*(Solution on p. 326.)*

A football quarterback has to choose between a pass play or a run play depending on how the defending team is going to react. If he chooses a pass play and the defending team is expecting a

pass, he expects to gain 4 yards, but if the defending team is expecting a run, he gains 20 yards. On the other hand, if he calls a run play and the defending team expects a pass, he gains 7 yards, and if he calls a run play and the defending team expects a run, he loses 2 yards. If you were the quarterback, what would your strategy be?

Exercise 20.27*(Solution on p. 326.)*

The Watermans go fishing every weekend either at Eel River or at Snake River. Unfortunately, so do the Nelsons. If both families show up at Eel River, the Watermans can hope to catch only 3 fish, but if the Watermans fish at Eel River and the Nelsons at Snake River, the Watermans can catch as many as 12 fish. On the other hand, if both families fish at Snake river, the Watermans can catch about 5 fish, and if Watermans fish at Snake river while the Nelsons fish at Eel river, the Watermans can catch up to 15 fish. Determine a mixed strategy for the Watermans, and the expected payoff.

Exercise 20.28*(Solution on p. 326.)*

Terry knows there is a quiz tomorrow, but does not remember whether it is in his math class or in his biology class. He has time to study for only one subject. If he studies math and there is a quiz in it, he gains 10 points and even if there is no quiz he gains two points for acquiring the extra knowledge which he will apply towards the final exam. If he studies biology and there is a quiz in it, he gains ten points but there is no gain if there is no quiz. Determine a mixed strategy for Terry, and the expected payoff.

Exercise 20.29*(Solution on p. 326.)*

Reduce the payoff matrix by dominance. Find the optimal strategy for each player and the value of the game.

a.
$$\begin{bmatrix} -3 & 1 & 2 \\ -3 & 5 & 3 \\ 2 & 4 & -1 \end{bmatrix}$$

b.
$$\begin{bmatrix} 1 & 2 & 3 \\ 4 & 1 & 4 \\ 2 & 3 & 4 \\ 1 & 2 & 2 \end{bmatrix}$$

c.
$$\begin{bmatrix} 4 & 3 & 9 & 7 \\ -7 & -5 & -3 & 5 \\ -1 & 4 & 5 & 8 \\ -3 & -5 & 1 & -1 \end{bmatrix}$$

d.
$$\begin{bmatrix} 2 & 3 & 1 & 5 \\ -2 & 2 & 1 & 3 \end{bmatrix}$$

e.
$$\begin{bmatrix} 0 & 3 & 2 & 1 \\ 0 & 2 & 1 & -7 \\ -4 & -9 & 5 & 4 \\ 4 & -7 & 6 & 6 \end{bmatrix}$$

$$\text{f. } \begin{bmatrix} 1 & 0 & 2 & 2 \\ 2 & 2 & 0 & 2 \\ 2 & -3 & 0 & 4 \\ 2 & -2 & -3 & 2 \end{bmatrix}$$

Solutions to Exercises in Chapter 20

Solutions to Game Theory: Homework

Solution to Exercise 20.1 (p. 315)

- a. The game is strictly determined. Optimal strategy for the row player is to always play row 1 and never row 2. In other words, his strategy is $\begin{bmatrix} 1 & 0 \end{bmatrix}$. The optimal strategy for the column player is to always to play column 1 and never play column 2. We write it as $\begin{bmatrix} 1 \\ 0 \end{bmatrix}$. When both players play their optimal strategy, the value of the game is 1.
- b.
- c. The game has no saddle point, therefore, it is not strictly determined.
- d.
- e. The game is strictly determined. The optimal strategy for the row player is to always play row 4, and never play any other row. We write his strategy as $\begin{bmatrix} 0 & 0 & 0 & 1 \end{bmatrix}$. The column player's strategy is $\begin{bmatrix} 0 \\ 1 \end{bmatrix}$. The value of the game is 2.
- f.

Solution to Exercise 20.3 (p. 316)

- a. $\begin{bmatrix} .05 & .10 \\ -.08 & -.12 \end{bmatrix}$
- b. The optimal strategy for the mayor is $\begin{bmatrix} 1 & 0 \end{bmatrix}$ and for his opponent is $\begin{bmatrix} 1 \\ 0 \end{bmatrix}$. In other words, both candidates should oppose abortion rights.

Solution to Exercise 20.5 (p. 316)

- a. The optimal strategy for the row player is $\begin{bmatrix} 1/2 & 1/2 \end{bmatrix}$. The optimal strategy for the column player is $\begin{bmatrix} 1/2 \\ 1/2 \end{bmatrix}$. The value of the game is 0.
- b.
- c. Optimal strategy for the row player is $\begin{bmatrix} 2/7 & 5/7 \end{bmatrix}$. The optimal strategy for the column player is $\begin{bmatrix} 6/7 \\ 1/7 \end{bmatrix}$. The value of the game is $16/7$.
- d.

Solution to Exercise 20.7 (p. 317)

- a. $\begin{bmatrix} 2 & -3 \\ -3 & 4 \end{bmatrix}$
- b. Optimal strategy for the row player is $\begin{bmatrix} 7/12 & 5/12 \end{bmatrix}$. The optimal strategy for the column player is $\begin{bmatrix} 7/12 \\ 5/12 \end{bmatrix}$. The value of the game is $-1/12$.

Solution to Exercise 20.9 (p. 317)

$$\begin{bmatrix} 2 & -1 \\ 0 & 3 \end{bmatrix}, R = \begin{bmatrix} 1/2 & 1/2 & 0 \end{bmatrix}, C = \begin{bmatrix} 2/3 \\ 1/3 \end{bmatrix}, \text{ The value} = 1 \quad (20.9)$$

Solution to Exercise 20.11 (p. 318)

$$\begin{bmatrix} 1 & -2 \\ -2 & 4 \end{bmatrix}, R = \begin{bmatrix} 2/3 & 1/3 & 0 \end{bmatrix}, C = \begin{bmatrix} 2/3 \\ 0 \\ 1/3 \end{bmatrix}, \text{ The value} = 0 \quad (20.10)$$

Solution to Exercise 20.13 (p. 318)

$$\begin{bmatrix} 0 & -4 \\ -2 & 4 \end{bmatrix}, R = \begin{bmatrix} .6 & 0 & .4 & 0 \end{bmatrix}, C = \begin{bmatrix} 0 \\ .8 \\ .2 \\ 0 \end{bmatrix}, \text{ The value} = -0.8 \quad (20.11)$$

Solution to Exercise 20.15 (p. 318)

$$\begin{bmatrix} 2 & -8 \\ 1 & 5 \end{bmatrix}, R = \begin{bmatrix} 0 & 2/7 & 5/7 & 0 \end{bmatrix}, C = \begin{bmatrix} 0 \\ 0 \\ 13/14 \\ 1/14 \end{bmatrix}, \text{ The value} = 9/7 \quad (20.12)$$

Solution to Exercise 20.17 (p. 319)

$$\text{a. } R = \begin{bmatrix} 0 & 1 \end{bmatrix}, C = \begin{bmatrix} 1 \\ 0 \end{bmatrix}, \text{ value} = 3$$

$$\text{b. } R = \begin{bmatrix} 1 & 0 & 0 \end{bmatrix}, C = \begin{bmatrix} 0 \\ 0 \\ 1 \end{bmatrix}, v = -1$$

$$\text{c. } R = \begin{bmatrix} 0 & 1 \end{bmatrix}, C = \begin{bmatrix} 0 \\ 1 \\ 0 \end{bmatrix}, \text{ value} = 3$$

$$\text{d. } R = \begin{bmatrix} 0 & 0 & 1 & 0 \end{bmatrix}, C = \begin{bmatrix} 0 \\ 1 \end{bmatrix} v = 3$$

Solution to Exercise 20.18 (p. 319)

$$\text{a. } \begin{bmatrix} -5 & 10 \\ 5 & 10 \end{bmatrix}$$

$$\text{b. } R = \begin{bmatrix} 0 & 1 \end{bmatrix}, C = \begin{bmatrix} 1 \\ 0 \end{bmatrix}, \text{ value} = 5 \text{ cents}$$

Solution to Exercise 20.19 (p. 319)

a. $\begin{bmatrix} 5 & 30 \\ -5 & 0 \end{bmatrix}$

b. $R = \begin{bmatrix} 1 & 0 \end{bmatrix} C = \begin{bmatrix} 1 \\ 0 \end{bmatrix}$, value = 5%

Solution to Exercise 20.20 (p. 319)

a. $\begin{bmatrix} .14 & .08 & .11 \\ .12 & .11 & .11 \\ .06 & .09 & .10 \end{bmatrix}$

b. $\begin{bmatrix} 0 & 1 & 0 \end{bmatrix}$, $\begin{bmatrix} 0 \\ 1 \\ 0 \end{bmatrix}$ or $\begin{bmatrix} 0 & 1 & 0 \end{bmatrix}$, $\begin{bmatrix} 0 \\ 0 \\ 1 \end{bmatrix}$, value = .11

Solution to Exercise 20.21 (p. 320)

a. $\begin{bmatrix} -.02 & .03 \\ .01 & -.01 \end{bmatrix}$

b. stocks = 2/7, CD's = 5/7

Solution to Exercise 20.22 (p. 320)

a. $\begin{bmatrix} 1/2 & 1/2 \end{bmatrix}$, $\begin{bmatrix} 1/2 \\ 1/2 \end{bmatrix}$, value = 0

b. $\begin{bmatrix} 5/9 & 4/9 \end{bmatrix}$, $\begin{bmatrix} 2/9 \\ 7/9 \end{bmatrix}$, value = 10/9

c. $\begin{bmatrix} 5/7 & 2/7 \end{bmatrix}$, $\begin{bmatrix} 6/7 \\ 1/7 \end{bmatrix}$, value = 23/7

d. $\begin{bmatrix} 1/2 & 1/2 \end{bmatrix}$, $\begin{bmatrix} 4/7 \\ 3/7 \end{bmatrix}$, value = 1

Solution to Exercise 20.23 (p. 320)

a. 19/8

b. 14/9

Solution to Exercise 20.24 (p. 320)

\$11,000

Solution to Exercise 20.25 (p. 320)

$$\begin{bmatrix} 1/2 & 1/2 \end{bmatrix}, \begin{bmatrix} 2/3 \\ 1/3 \end{bmatrix}, v = 0 \quad (20.13)$$

Solution to Exercise 20.26 (p. 320)

$$\text{Pass} = 9/25, \text{Run} = 16/25 \quad (20.14)$$

Solution to Exercise 20.27 (p. 321)

$$\left[\begin{array}{cc} 10/19 & 9/19 \end{array} \right], \text{payoff} = 9.58 \text{ fish} \quad (20.15)$$

Solution to Exercise 20.28 (p. 321)

$$\left[\begin{array}{cc} 1 & 0 \end{array} \right], \text{payoff} = 2 \text{ points} \quad (20.16)$$

Solution to Exercise 20.29 (p. 321)

$$\text{a. } \left[\begin{array}{cc} -3 & 3 \\ 2 & -1 \end{array} \right], \left[\begin{array}{ccc} 0 & 1/3 & 2/3 \end{array} \right], \left[\begin{array}{c} 4/9 \\ 0 \\ 5/9 \end{array} \right], \text{value} = 1/3$$

$$\text{b. } \left[\begin{array}{cc} 4 & 1 \\ 2 & 3 \end{array} \right], \left[\begin{array}{cccc} 0 & 1/4 & 3/4 & 0 \end{array} \right], \left[\begin{array}{c} 1/2 \\ 1/2 \\ 0 \end{array} \right], \text{value} = 5/2$$

$$\text{c. } \left[\begin{array}{cc} 4 & 3 \\ -1 & 4 \end{array} \right], \left[\begin{array}{cccc} 5/6 & 0 & 1/6 & 0 \end{array} \right], \left[\begin{array}{c} 1/6 \\ 5/6 \\ 0 \\ 0 \end{array} \right], \text{value} = 19/6$$

$$\text{d. } \left[\begin{array}{cc} 2 & 1 \\ -2 & 1 \end{array} \right], \left[\begin{array}{cc} 3/4 & 1/4 \end{array} \right], \left[\begin{array}{c} 0 \\ 0 \\ 1 \\ 0 \end{array} \right], \text{value} = 1$$

$$\text{e. } \left[\begin{array}{cc} 0 & 3 \\ 4 & -7 \end{array} \right], \left[\begin{array}{cccc} 11/14 & 0 & 0 & 3/14 \end{array} \right], \left[\begin{array}{c} 10/14 \\ 4/14 \\ 0 \\ 0 \end{array} \right], \text{value} = 6/7$$

$$\text{f. } \left[\begin{array}{cc} 0 & 2 \\ 2 & 0 \end{array} \right], \left[\begin{array}{cccc} 1/2 & 1/2 & 0 & 0 \end{array} \right], \left[\begin{array}{c} 0 \\ 1/2 \\ 1/2 \\ 0 \end{array} \right], \text{value} = 1$$

Chapter 21

Practice Exam¹

Exercise 21.1 (Solution on p. 332.)

What will the future value of \$5000 be in 5 years at 8% compounded quarterly?

Exercise 21.2 (Solution on p. 332.)

A bank pays 8% compounded quarterly, what is the effective interest rate?

Exercise 21.3 (Solution on p. 332.)

Each year a sum of \$2200 is placed in an IRA account paying 12%. After 10 years what will the final amount be?

Exercise 21.4 (Solution on p. 332.)

If \$5000 is invested at 8% compounded daily for 3 years, find the final amount.

Exercise 21.5 (Solution on p. 332.)

Find the present value of \$200 per month at 12% for 4 years.

Exercise 21.6 (Solution on p. 332.)

A \$12,000 car loan is amortized at 6% over 6 years. Find the monthly payment.

Exercise 21.7 (Solution on p. 332.)

In problem 6, what will the balance of the loan be after 4 years?

Exercise 21.8 (Solution on p. 332.)

If in problem 6, the loan is amortized over 3 years, what will the monthly payment be?

Exercise 21.9 (Solution on p. 332.)

A \$24,000 car has a useful life of 6 years. It can be leased for \$400 per month. If the current interest rate is 6%, is it better to lease or to buy?

Exercise 21.10 (Solution on p. 332.)

What monthly payment will amount to \$10,000 in 5 years at 11%?

Exercise 21.11 (Solution on p. 332.)

A bond has a face value of \$1000 and is due in 5 years. It pays \$45 interest every 6 months. If the current interest rate is 12%, what is the fair market value of the bond?

Exercise 21.12 (Solution on p. 332.)

A company produces solar panels. The total cost of 20 panels is \$2100, and the cost of 60 panels is \$3900. Express the cost y in terms of the number of panels x .

For problems 13, 14 and 15, the final tableaux is given below

¹This content is available online at <<http://cnx.org/content/m18911/1.2/>>.

0	0	1	5	-2	4	0	100
1	0	0	-1	7	4	0	200
0	1	0	6	10	-7	0	400
0	0	0	75	5	90	1	2500

Figure 21.1

Exercise 21.13 *(Solution on p. 332.)*

If the initial problem is a maximization problem, what is the maximum value?

Exercise 21.14 *(Solution on p. 332.)*

If the initial problem is a maximization one, at what point does the maximum value occur?

Exercise 21.15 *(Solution on p. 332.)*

If the initial problem is a minimization one, at what point does the minimum value occur?

Exercise 21.16 *(Solution on p. 332.)*

At a price of \$3, 100 units are demanded of a product. At a price of \$5, 50 units are demanded. If x is the price and D the number of units demanded, write the demand equation.

For problems 17 and 18, use the following system of equations.

$$2x + 4y = 10$$

$$3x + 6y = 15$$

$$5x + 10y = 27$$

Exercise 21.17 *(Solution on p. 332.)*

If $x = 1$, what is the value of y ?

Exercise 21.18 *(Solution on p. 332.)*

How many solutions does this system have?

Problems 19 - 22 refer to the maximization problem below to be done using the simplex method.

A company makes two types of widgets, Regular and Deluxe. Each type of widget requires the use of three machines for its production. The Regular widget requires three hours on machine I, one hour on machine II, and one hour on machine III, and sells for \$10. The Deluxe widget requires one hour on machine I, two hours on machine II, and one hour on machine III, and sells for \$20. The maximum number hours available on Machines I, II, and III are 120, 100, and 40, respectively.

Exercise 21.19 *(Solution on p. 332.)*

What are the coefficients of the objective function?

Exercise 21.20 *(Solution on p. 332.)*

What is the constraint imposed by Machine III?

Exercise 21.21 *(Solution on p. 332.)*

In solving this problem using the simplex method, how many slack variables are needed?

Exercise 21.22 *(Solution on p. 332.)*

After the first full pivot operation, what is the current revenue?

Exercise 21.23 *(Solution on p. 332.)*

A firm produces floppies at a variable cost of \$1.20 per disk and a fixed cost of \$1800. If the disk sells for \$3 each, find the break-even point.

Problems 24 - 25 refer to the following minimization problem:

A diet must contain at least 60 units of protein, and 30 units of fat. Food A provides 2 grams of protein and 4 grams of fat, and costs 30 cents. Food B provides 6 grams of protein and 2 grams of fat, and costs 20 cents.

Exercise 21.24 (Solution on p. 333.)

Graph the constraints, and shade the feasibility region.

Exercise 21.25 (Solution on p. 333.)

Write the cost function.

For problems 26 and 27, the supply and demand equations are given as follows:

$$S = 2/3x - 100, D = -4/3x + 500, \text{ where } x \text{ is the price.}$$

Exercise 21.26 (Solution on p. 333.)

Find the equilibrium price.

Exercise 21.27 (Solution on p. 333.)

How many items will be demanded at that price?

Exercise 21.28 (Solution on p. 333.)

If there are 5 people in a room, what is the probability that no two have the same birthday?

Exercise 21.29 (Solution on p. 333.)

A and B are mutually exclusive, $P(A) = .4$, $P(B) = .5$ find $P(A \text{ and } B)$.

Exercise 21.30 (Solution on p. 333.)

A and B are independent. $P(A) = .4$, $P(A \text{ and } B) = .24$, find $P(B)$.

Exercise 21.31 (Solution on p. 333.)

What is the probability of getting 3 heads if a coin is tossed 5 times?

Exercise 21.32 (Solution on p. 333.)

If $P(A) = .5$, $P(B) = .4$ and $P(A \text{ and } B) = .2$, find $P(A \text{ or } B)$.

Exercise 21.33 (Solution on p. 333.)

How many different ways can two boys and three girls be chosen from a total of 6 boys and 8 girls?

Problems 34 - 36 refer to the following information.

Companies A , B , and C produce 15%, 40%, and 45% respectively of the major appliances in an area. One percent of company A appliances, 2% of company B appliances, and 3% of company C appliances require service within the first year.

Exercise 21.34 (Solution on p. 333.)

What is the probability that an appliance chosen at random is defective?

Exercise 21.35 (Solution on p. 333.)

If an appliance is chosen at random and found to be defective, what is the probability that it came from company B ?

Exercise 21.36 (Solution on p. 333.)

Suppose it was manufactured by company B , what is the probability it is a defective appliance?

Exercise 21.37 (Solution on p. 333.)

On 30% of his quizzes a student receives a score of 8, and on 70% his score is 9, what is his average?

Problems 38 - 40 refer to the following.

An urn contains 3 red, 4 white and 5 blue marbles, and two marbles are drawn at random.

Exercise 21.38 (Solution on p. 333.)

What is the chance of getting a blue marble on the second draw given that a red has been drawn on the first?

Exercise 21.39 (Solution on p. 333.)

What is the probability of obtaining one white and one other marble?

Exercise 21.40*(Solution on p. 333.)*

What is the probability of obtaining at least one white marble?

For problems 41 - 43, consider the following transition matrix giving the probabilities for the next purchase of Tide and Brand X.

		Next purchase	
		Tide	Brand X
Present	Tide	.8	.2
Purchase	Brand X	.4	.6

Table 21.1**Exercise 21.41***(Solution on p. 333.)*

What percentage of the Tide people will buy Brand X next month?

Exercise 21.42*(Solution on p. 333.)*

If the original share of the market is (.25.75), what will the share be two months from now?

Exercise 21.43*(Solution on p. 333.)*

What will the long term share of the market be?

For problems 44 - 46, consider the following transition matrix for an absorbing Markov Chain.

	S1	S2	S3	S4	
S1	1	0	0	0]
S2	.2	.6	.2	0	
S3	0	.2	.4	.4	
S4	0	0	0	1	

Figure 21.2**Exercise 21.44***(Solution on p. 333.)*

Identify the absorbing states.

Exercise 21.45*(Solution on p. 333.)*

Write the solution matrix.

Exercise 21.46*(Solution on p. 334.)*

Find the probability of ending in state 4, given one started in state 2.

Exercise 21.47*(Solution on p. 334.)*

Given the 3×3 game $\begin{bmatrix} 2 & 3 & 3 \\ 1 & 0 & -1 \\ 0 & 0 & 4 \end{bmatrix}$, find the optimal strategy for the column player.

For problems 48 - 50, consider the following 2×2 payoff matrix.

$$\begin{bmatrix} -1 & 0 \\ 1/4 & -1/4 \end{bmatrix}$$

Exercise 21.48

(Solution on p. 334.)

Find the row player's optimal strategy.

Exercise 21.49

(Solution on p. 334.)

Find the column player's optimal strategy.

Exercise 21.50

(Solution on p. 334.)

Find the value of the game if the row and column players' strategies are $\begin{bmatrix} .7 & .3 \end{bmatrix}$, and $\begin{bmatrix} .5 \\ .5 \end{bmatrix}$, respectively.

Solutions to Exercises in Chapter 21

Solutions to Practice Exam

Solution to Exercise 21.1 (p. 327)

7,429.74

Solution to Exercise 21.2 (p. 327)

8.24%

Solution to Exercise 21.3 (p. 327)

38,607.22

Solution to Exercise 21.4 (p. 327)

6,356.08

Solution to Exercise 21.5 (p. 327)

7,594.79

Solution to Exercise 21.6 (p. 327)

198.87

Solution to Exercise 21.7 (p. 327)

4,487.08

Solution to Exercise 21.8 (p. 327)

365.06

Solution to Exercise 21.9 (p. 327)

buy

Solution to Exercise 21.10 (p. 327)

125.75

Solution to Exercise 21.11 (p. 327)

$$559.39 + 331.20 = 889.59 \quad (21.1)$$

Solution to Exercise 21.12 (p. 327)

$$y = 45x + 1200 \quad (21.2)$$

Solution to Exercise 21.13 (p. 328)

2500

Solution to Exercise 21.14 (p. 328)

(200, 400, 100)

Solution to Exercise 21.15 (p. 328)

(75, 5, 90)

Solution to Exercise 21.16 (p. 328)

$D = -25x + 175$

Solution to Exercise 21.17 (p. 328)

No solution

Solution to Exercise 21.18 (p. 328)

None

Solution to Exercise 21.19 (p. 328)

10, 20

Solution to Exercise 21.20 (p. 328)

$x_1 + x_2 \leq 40$

Solution to Exercise 21.21 (p. 328)

3

Solution to Exercise 21.22 (p. 328)

800

- Solution to Exercise 21.23 (p. 328)**
(1000, 3000)
- Solution to Exercise 21.24 (p. 329)**
Graph
- Solution to Exercise 21.25 (p. 329)**
 $C = .30x + .20y$
- Solution to Exercise 21.26 (p. 329)**
300
- Solution to Exercise 21.27 (p. 329)**
100
- Solution to Exercise 21.28 (p. 329)**
.97286
- Solution to Exercise 21.29 (p. 329)**
0
- Solution to Exercise 21.30 (p. 329)**
.6
- Solution to Exercise 21.31 (p. 329)**
.3125
- Solution to Exercise 21.32 (p. 329)**
.7
- Solution to Exercise 21.33 (p. 329)**
840
- Solution to Exercise 21.34 (p. 329)**
.023
- Solution to Exercise 21.35 (p. 329)**
.3478
- Solution to Exercise 21.36 (p. 329)**
.02
- Solution to Exercise 21.37 (p. 329)**
8.7
- Solution to Exercise 21.38 (p. 329)**
5/11
- Solution to Exercise 21.39 (p. 329)**
.4848
- Solution to Exercise 21.40 (p. 330)**
.5758
- Solution to Exercise 21.41 (p. 330)**
.2
- Solution to Exercise 21.42 (p. 330)**
 $\begin{bmatrix} .6 & .4 \end{bmatrix}$
- Solution to Exercise 21.43 (p. 330)**
 $\begin{bmatrix} 2/3 & 1/3 \end{bmatrix}$
- Solution to Exercise 21.44 (p. 330)**
1 and 4
- Solution to Exercise 21.45 (p. 330)**

$$\begin{matrix} & & 1 & 4 \\ 2 & \left[\begin{array}{cc} & \\ & \end{array} \right. & .6 & .4 \\ 3 & & .2 & .8 \end{matrix} \left. \vphantom{\begin{matrix} & & 1 & 4 \\ 2 & \left[\begin{array}{cc} & \\ & \end{array} \right. & .6 & .4 \\ 3 & & .2 & .8 \end{matrix}} \right]$$

Figure 21.3

Solution to Exercise 21.46 (p. 330)

.4

Solution to Exercise 21.47 (p. 330)

$$\begin{bmatrix} 1 \\ 0 \\ 0 \end{bmatrix}$$

Solution to Exercise 21.48 (p. 331)

$$\begin{bmatrix} 1/3 & 2/3 \end{bmatrix}$$

Solution to Exercise 21.49 (p. 331)

$$\begin{bmatrix} 1/6 \\ 5/6 \end{bmatrix}$$

Solution to Exercise 21.50 (p. 331)

-- .35

Glossary

E Expected Value

If an experiment has the following probability distribution,

Payoff	x_1	x_2	x_3	\cdots	x_n
Probability	$p(x_1)$	$p(x_2)$	$p(x_3)$	\cdots	$p(x_n)$

Table 15.3

then the expected value of the experiment is

$$\text{Expected Value} = x_1p(x_1) + x_2p(x_2) + x_3p(x_3) + \cdots + x_np(x_n)$$

I

If (x_1, y_1) and (x_2, y_2) are two different points on a line, then the slope of the line is

$$\text{Slope} = m = \frac{y_2 - y_1}{x_2 - x_1}$$

S Sample Spaces

A sample space of an experiment is the set of all possible outcomes.

T The Duality Principle:

The objective function of the minimization problem reaches its minimum if and only if the objective function of its dual reaches its maximum. And when they do, they are equal.

The Law of 70:

The number of years required to double money = $70 \div$ interest rate

Index of Keywords and Terms

Keywords are listed by the section with that keyword (page numbers are in parentheses). Keywords do not necessarily appear in the text of the page. They are merely associated with that section. *Ex.* apples, § 1.1 (1) **Terms** are referenced by the page they appear on. *Ex.* apples, 1

- A** Absorbing Markov Chains, § 17(277), § 18(291)
 addition rule, § 13(209), § 14(229)
 annuities, § 9(135), § 10(155)
 applications, § 1(1), § 2(25)
- B** Bayes' Formula, § 15(251), § 16(265)
 binomial, § 15(251), § 16(265)
 binomial theorem, § 11(169), § 12(193)
- C** combinations, § 11(169), § 12(193), § 13(209), § 14(229)
 compound interest, § 9(135), § 10(155)
 conditional probability, § 13(209), § 14(229)
 counting problems, § 11(169), § 12(193)
- E** Expected Value, 260
- F** finances, § 9(135), § 10(155)
- G** game theory, § 19(305), § 20(315)
 Gauss-Jordan method, § 3(43), § 4(77)
 graphing linear equations, § 1(1), § 2(25)
- I** independence, § 13(209), § 14(229)
- L** linear equations, § 1(1), § 2(25)
 linear programming, § 5(97), § 6(109), § 7(115), § 8(129)
 linear systems, § 1(1), § 2(25), § 3(43), § 4(77)
 loan payments, § 9(135), § 10(155)
- M** Markov Chains, § 17(277), § 18(291)
- matrices, § 3(43), § 4(77), § 5(97), § 6(109), § 7(115), § 8(129), § 17(277), § 18(291)
 matrix inverse method, § 3(43), § 4(77)
 matrix operations, § 3(43), § 4(77)
 maximization, § 7(115), § 8(129)
 minimization, § 7(115), § 8(129)
 mixed strategy, § 19(305), § 20(315)
 multiplication axiom, § 11(169), § 12(193)
 mutual exclusion, § 13(209), § 14(229)
- O** objective function, § 5(97), § 6(109)
- P** permutations, § 11(169), § 12(193)
 probability, § 13(209), § 14(229), § 15(251), § 16(265)
- R** Regular Markov Chains, § 17(277), § 18(291)
- S** Sample Spaces, 209
 set theory, § 11(169), § 12(193)
 simple interest, § 9(135), § 10(155)
 simplex method, § 7(115), § 8(129)
 sinking funds, § 9(135), § 10(155)
 slope, § 1(1), § 2(25)
 spaces, § 13(209), § 14(229)
- T** The Duality Principle:, 125
 The Law of 70:, 143
 tree diagrams, § 13(209), § 14(229), § 15(251), § 16(265)
 trends, § 17(277), § 18(291)
- V** venn diagrams, § 11(169), § 12(193)

Attributions

Collection: *Applied Finite Mathematics*
Edited by: Rupinder Sekhon
URL: <http://cnx.org/content/col10613/1.5/>
License: <http://creativecommons.org/licenses/by/3.0/>

Module: "Linear Equations"
By: Rupinder Sekhon
URL: <http://cnx.org/content/m18901/1.2/>
Pages: 1-23
Copyright: Rupinder Sekhon
License: <http://creativecommons.org/licenses/by/3.0/>

Module: "Linear Equations: Homework"
By: UniqU, LLC
URL: <http://cnx.org/content/m38636/1.2/>
Pages: 25-41
Copyright: UniqU, LLC
License: <http://creativecommons.org/licenses/by/3.0/>
Based on: Applied Finite Mathematics: Chapter 01
By: Rupinder Sekhon
URL: <http://cnx.org/content/m18901/1.1/>

Module: "Matrices"
By: Rupinder Sekhon
URL: <http://cnx.org/content/m18902/1.2/>
Pages: 43-75
Copyright: Rupinder Sekhon
License: <http://creativecommons.org/licenses/by/3.0/>

Module: "Matrices: Homework"
By: UniqU, LLC
URL: <http://cnx.org/content/m38640/1.2/>
Pages: 77-95
Copyright: UniqU, LLC
License: <http://creativecommons.org/licenses/by/3.0/>
Based on: Applied Finite Mathematics: Chapter 02
By: Rupinder Sekhon
URL: <http://cnx.org/content/m18902/1.1/>

Module: "Linear Programming: A Geometric Approach"
By: Rupinder Sekhon
URL: <http://cnx.org/content/m18903/1.2/>
Pages: 97-108
Copyright: Rupinder Sekhon
License: <http://creativecommons.org/licenses/by/3.0/>

Module: "Linear Programming: A Geometrical Approach: Homework"

By: UniqU, LLC

URL: <http://cnx.org/content/m38650/1.1/>

Pages: 109-113

Copyright: UniqU, LLC

License: <http://creativecommons.org/licenses/by/3.0/>

Based on: Applied Finite Mathematics: Chapter 03

By: Rupinder Sekhon

URL: <http://cnx.org/content/m18903/1.1/>

Module: "Linear Programming: The Simplex Method"

By: Rupinder Sekhon

URL: <http://cnx.org/content/m18904/1.2/>

Pages: 115-127

Copyright: Rupinder Sekhon

License: <http://creativecommons.org/licenses/by/3.0/>

Module: "Linear Programming: The Simplex Method: Homework"

By: UniqU, LLC

URL: <http://cnx.org/content/m38649/1.2/>

Pages: 129-133

Copyright: UniqU, LLC

License: <http://creativecommons.org/licenses/by/3.0/>

Based on: Applied Finite Mathematics: Chapter 04

By: Rupinder Sekhon

URL: <http://cnx.org/content/m18904/1.1/>

Module: "Mathematics of Finance"

By: Rupinder Sekhon

URL: <http://cnx.org/content/m18905/1.2/>

Pages: 135-153

Copyright: Rupinder Sekhon

License: <http://creativecommons.org/licenses/by/3.0/>

Module: "Mathematics of Finance: Homework"

By: UniqU, LLC

URL: <http://cnx.org/content/m38651/1.1/>

Pages: 155-168

Copyright: UniqU, LLC

License: <http://creativecommons.org/licenses/by/3.0/>

Based on: Applied Finite Mathematics: Chapter 05

By: Rupinder Sekhon

URL: <http://cnx.org/content/m18905/1.1/>

Module: "Sets and Counting"

By: Rupinder Sekhon

URL: <http://cnx.org/content/m18906/1.2/>

Pages: 169-191

Copyright: Rupinder Sekhon

License: <http://creativecommons.org/licenses/by/3.0/>

Module: "Sets and Counting: Homework"
By: UniqU, LLC
URL: <http://cnx.org/content/m38653/1.1/>
Pages: 193-208
Copyright: UniqU, LLC
License: <http://creativecommons.org/licenses/by/3.0/>
Based on: Applied Finite Mathematics: Chapter 06
By: Rupinder Sekhon
URL: <http://cnx.org/content/m18906/1.1/>

Module: "Probability"
By: Rupinder Sekhon
URL: <http://cnx.org/content/m18907/1.2/>
Pages: 209-228
Copyright: Rupinder Sekhon
License: <http://creativecommons.org/licenses/by/3.0/>

Module: "Probability: Homework"
By: UniqU, LLC
URL: <http://cnx.org/content/m38666/1.1/>
Pages: 229-249
Copyright: UniqU, LLC
License: <http://creativecommons.org/licenses/by/3.0/>
Based on: Applied Finite Mathematics: Chapter 07
By: Rupinder Sekhon
URL: <http://cnx.org/content/m18907/1.1/>

Module: "More Probability"
By: Rupinder Sekhon
URL: <http://cnx.org/content/m18908/1.2/>
Pages: 251-264
Copyright: Rupinder Sekhon
License: <http://creativecommons.org/licenses/by/3.0/>

Module: "More Probability: Homework"
By: UniqU, LLC
URL: <http://cnx.org/content/m38660/1.1/>
Pages: 265-275
Copyright: UniqU, LLC
License: <http://creativecommons.org/licenses/by/3.0/>
Based on: Applied Finite Mathematics: Chapter 08
By: Rupinder Sekhon
URL: <http://cnx.org/content/m18908/1.1/>

Module: "Markov Chains"
By: Rupinder Sekhon
URL: <http://cnx.org/content/m18909/1.2/>
Pages: 277-290
Copyright: Rupinder Sekhon
License: <http://creativecommons.org/licenses/by/3.0/>

Module: "Markov Chains: Homework"

By: UniqU, LLC

URL: <http://cnx.org/content/m38663/1.1/>

Pages: 291-303

Copyright: UniqU, LLC

License: <http://creativecommons.org/licenses/by/3.0/>

Based on: Applied Finite Mathematics: Chapter 09

By: Rupinder Sekhon

URL: <http://cnx.org/content/m18909/1.1/>

Module: "Game Theory"

By: Rupinder Sekhon

URL: <http://cnx.org/content/m18910/1.2/>

Pages: 305-313

Copyright: Rupinder Sekhon

License: <http://creativecommons.org/licenses/by/3.0/>

Module: "Game Theory: Homework"

By: UniqU, LLC

URL: <http://cnx.org/content/m38665/1.1/>

Pages: 315-326

Copyright: UniqU, LLC

License: <http://creativecommons.org/licenses/by/3.0/>

Based on: Applied Finite Mathematics: Chapter 10

By: Rupinder Sekhon

URL: <http://cnx.org/content/m18910/1.1/>

Module: "Applied Finite Mathematics: Practice Exam"

Used here as: "Practice Exam"

By: Rupinder Sekhon

URL: <http://cnx.org/content/m18911/1.2/>

Pages: 327-334

Copyright: Rupinder Sekhon

License: <http://creativecommons.org/licenses/by/3.0/>

Applied Finite Mathematics

Applied Finite Mathematics covers topics including linear equations, matrices, linear programming, the mathematics of finance, sets and counting, probability, Markov chains, and game theory.

About Connexions

Since 1999, Connexions has been pioneering a global system where anyone can create course materials and make them fully accessible and easily reusable free of charge. We are a Web-based authoring, teaching and learning environment open to anyone interested in education, including students, teachers, professors and lifelong learners. We connect ideas and facilitate educational communities.

Connexions's modular, interactive courses are in use worldwide by universities, community colleges, K-12 schools, distance learners, and lifelong learners. Connexions materials are in many languages, including English, Spanish, Chinese, Japanese, Italian, Vietnamese, French, Portuguese, and Thai. Connexions is part of an exciting new information distribution system that allows for **Print on Demand Books**. Connexions has partnered with innovative on-demand publisher QOOP to accelerate the delivery of printed course materials and textbooks into classrooms worldwide at lower prices than traditional academic publishers.